

Ultra SCSI XIO™ Board Installation Instructions

Document Number 108-0157-001

Contributors

Written by Carolyn Curtis

Illustrated by Cheri Brown and Dan Young

Production by Linda Rae Sande

Engineering contributions by Patrick Conway, Carl Rigg, Suzy Jones, John Burger, and Ed Freige

© Copyright 1996, Silicon Graphics, Inc.— All Rights Reserved

This document contains proprietary and confidential information of Silicon Graphics, Inc. The contents of this document may not be disclosed to third parties, copied, or duplicated in any form, in whole or in part, without the prior written permission of Silicon Graphics, Inc.

Restricted Rights Legend

Use, duplication, or disclosure of the technical data contained in this document by the Government is subject to restrictions as set forth in subdivision (c) (1) (ii) of the Rights in Technical Data and Computer Software clause at DFARS 52.227-7013 and/or in similar or successor clauses in the FAR, or in the DOD or NASA FAR Supplement. Unpublished rights reserved under the Copyright Laws of the United States. Contractor/manufacturer is Silicon Graphics, Inc., 2011 N. Shoreline Blvd., Mountain View, CA 94043-1389.

FCC Warning

This equipment has been tested and found compliant with the limits for a Class A digital device, pursuant to Part 15 of the FCC rules. These limits are designed to provide reasonable protection against harmful interference when the equipment is operated in a commercial environment. This equipment generates, uses, and can radiate radio frequency energy and, if not installed and used in accordance with the instruction manual, may cause harmful interference to radio communications. Operation of this equipment in a residential area is likely to cause harmful interference in which case the user will be required to correct the interference at his own expense.

Attention

This product requires the use of external shielded cables in order to maintain compliance pursuant to Part 15 of the FCC Rules.

International Special Committee on Radio Interference (CISPR)

This equipment has been tested to and is in compliance with the Class A limits per CISPR publication 22, Limits and Methods of Measurement of Radio Interference Characteristics of Information Technology Equipment; Germany's BZT Class A limits for Information Technology Equipment; and Japan's VCCI Class 1 limits.

Canadian Department of Communications Statement

This digital apparatus does not exceed the Class A limits for radio noise emissions from digital apparatus as set out in the Radio Interference Regulations of the Canadian Department of Communications.

Attention

Le présent appareil numérique n'émet pas de perturbations radioélectriques dépassant les normes applicables aux appareils numériques de Classe A prescrites dans le Règlement sur les interférences radioélectriques établi par le Ministère des Communications du Canada.

VCCI Class 1 Statement for Japan

この装置は、第一種情報装置（商工業地域において使用されるべき情報装置）で商工業地域での電波障害防止を目的とした情報処理装置等電波障害自主規制協議会(VCCI)基準に適合しております。

従って、住宅地域またはその隣接した地域で使用すると、ラジオ、テレビジョン受信機等に受信障害を与えることがあります。

取扱説明書に従って正しい取り扱いをして下さい。

この装置は、第一種情報装置（商工業地域において使用されるべき情報装置）で商工業地域での電波障害防止を目的とした情報処理装置等電波障害自主規制協議会(VCCI)基準に適合しております。

従って、住宅地域またはその隣接した地域で使用すると、ラジオ、テレビジョン受信機等に受信障害を与えることがあります。

取扱説明書に従って正しい取り扱いをして下さい。

Ultra SCSI XIO Board Installation Instructions Document Number 108-0157-001

Silicon Graphics, Inc.
Mountain View, California

Silicon Graphics, the Silicon Graphics logo, and Onyx are registered trademarks and IRIX, Onyx2, Origin, Origin 2000, PCI Adapter, and XIO are trademarks of Silicon Graphics, Inc.

Contents

About This Guide.....	xi
Audience	xi
Structure of This Guide	xi
1. Kit Contents	1-1
1.1 Option Components	1-1
1.2 XIO and Ultra SCSI Board Components.....	1-1
1.2.1 Hook Actuator	1-4
1.2.2 Compression Connector.....	1-4
1.3 Cables.....	1-7
2. Installing the Option.....	2-1
2.1 Selecting an XIO Slot for the Ultra SCSI Board.....	2-1
2.1.1 I/O for Origin2000 and Onyx2 Systems.....	2-2
2.1.2 Determining the Available XIO Slots.....	2-4
2.1.3 Ultra SCSI Board Placement Restrictions	2-5
2.1.4 Planning Ultra SCSI Board Placement	2-6
2.2 Installing the Ultra SCSI Option Board.....	2-6
2.3 Cabling the Ultra SCSI Board.....	2-11
2.4 Testing the New Installation	2-15
3. Maintenance.....	3-1
3.1 Removing the Ultra SCSI Option Board	3-1
3.2 Cleaning the Compression Connector	3-3
A. Ultra SCSI P Connector Pinouts	A-1

Figures

Figure 1-1	Ultra SCSI XIO Board	1-3
Figure 1-2	Ultra SCSI Board Diagram.....	1-4
Figure 1-3	Ultra SCSI Board Compression Connector	1-5
Figure 1-4	Compression Connector Protective Cover.....	1-6
Figure 1-5	Ultra SCSI Board Connectors and Cables.....	1-7
Figure 2-1	I/O in the Origin2000 Deskside Chassis	2-2
Figure 2-2	I/O in the Onyx2 Deskside Chassis	2-3
Figure 2-3	Board Configuration and Layout for System Module.....	2-4
Figure 2-4	Router Board, Node Boards, and XIO Boards	2-5
Figure 2-5	XIO Cardcage Holding Brackets and Cover Blanks	2-7
Figure 2-6	Removing the Protective Cover From the Compression Connector.....	2-8
Figure 2-7	Ultra SCSI Board Orientation (Origin2000 Systems and Onyx2 Rackmount)	2-9
Figure 2-8	Ultra SCSI Board Orientation (Onyx2 Deskside)	2-9
Figure 2-9	Installing the Ultra SCSI Board	2-10
Figure 2-10	Ultra SCSI Board Connectors and Cables.....	2-12
Figure 2-11	XIO Cable Guide (Rackmount System Only)	2-13
Figure 2-12	Attaching an Ultra SCSI Cable	2-14
Figure 3-1	XIO Cardcage Holding Brackets and Cover Blanks	3-2
Figure 3-2	Cleaning the Compression Connector	3-3

Tables

Table 1-1	Important Ultra SCSI Board Components.....	1-2
Table 2-1	Maximum Cable Lengths for SCSI Options.....	2-6
Table A-1	Ultra SCSI P Connector Pinouts.....	A-1

About This Guide

The Silicon Graphics® Ultra SCSI external SCSI (Small Computer Systems Interface) expander option board is a half-height XIO™ board (marketing code XT-SCSI-4P) that provides up to four additional external SCSI ports for an Origin2000™ or Onyx2™ desktop and rackmount system.

This guide explains how to install and configure the Ultra SCSI XIO option board, how to cable the option board to SCSI peripherals, and how to remove an Ultra SCSI board.

Audience

The instructions in this guide are intended for Silicon Graphics System Support Engineers only. You should be familiar with the Origin2000 desktop and rackmount systems and the Onyx2 desktop and rackmount systems, and Silicon Graphics SCSI peripherals. You should also have a general knowledge of SCSI.

Structure of This Guide

This guide consists of the following chapters and appendix:

- Chapter 1, “Kit Contents,” summarizes option components and briefly describes XIO board and Ultra SCSI board features.
- Chapter 2, “Installing the Option,” explains how to select an XIO slot for the Ultra SCSI board, how to install the board, and how to cable it.
- Chapter 3, “Maintenance,” explains how to clean the board’s compression connector and how to remove an Ultra SCSI board.
- Appendix A, “Ultra SCSI P Connector Pinouts,” gives technical data, including pinouts.

Besides this guide, you should also have available the installation guide for the host system in which the board is to be installed and the installation guides for the SCSI peripherals with which the board interfaces.

Chapter 1

Kit Contents

This chapter consists of these sections:

- Section 1.1, “Option Components”
- Section 1.2, “XIO and Ultra SCSI Board Components”
- Section 1.3, “Cables”

1.1 Option Components

The option consists of a board (030-0872-002), two Y cables (three feet or eight feet long) and sheets of labels. The board has four Fast-20 channels:

- channel 0: differential or single-ended (autosensing)
- channels 1, 2 and 3, differential only

Label sheets included in the option contain peel-off stickers for modules and for XIO slot/SCSI channel designation.

1.2 XIO and Ultra SCSI Board Components

XIO boards are optional products for Silicon Graphics platforms that are based on the scalable shared-memory multiprocessing (SSMP) architecture. XIO boards are installed into the XIO slots of Origin2000 and Onyx2 systems. Each active XIO slot provides up to 800 megabytes per second of bidirectional bandwidth (that is, 400 megabytes in each direction) through a nonblocking crossbar switch on the system’s midplane. All XIO slots in a system can be active simultaneously. Actual delivered bandwidth depends on the PCI bus on the Ultra SCSI option board.

Table 1-1 summarizes important components of the Ultra SCSI XIO board.

Table 1-1 Important Ultra SCSI Board Components

Component	Explanation
Custom SCSI ports	Two ports: top port is channels 0 and 1, bottom port is channels 2 and 3, when the board is oriented with the hook actuator at the top.
Compression connector	Provides communication between the board and the system via the midplane or frontplane.
Connector hooks	Hold compression connector securely to midplane or frontplane. There is one hook on each side of the compression connector. The hook actuator (next entry in this list) pushes/pulls the hooks into/out of the locked position.
Hook actuator	Device for moving hooks into and out of their locked position on the midplane.
Thick side of board	The surface of the board that has the compression connector and the tallest components.
Thin side of board	The side of the board with low-profile components.

Figure 1-1 shows components of the Ultra SCSI board.

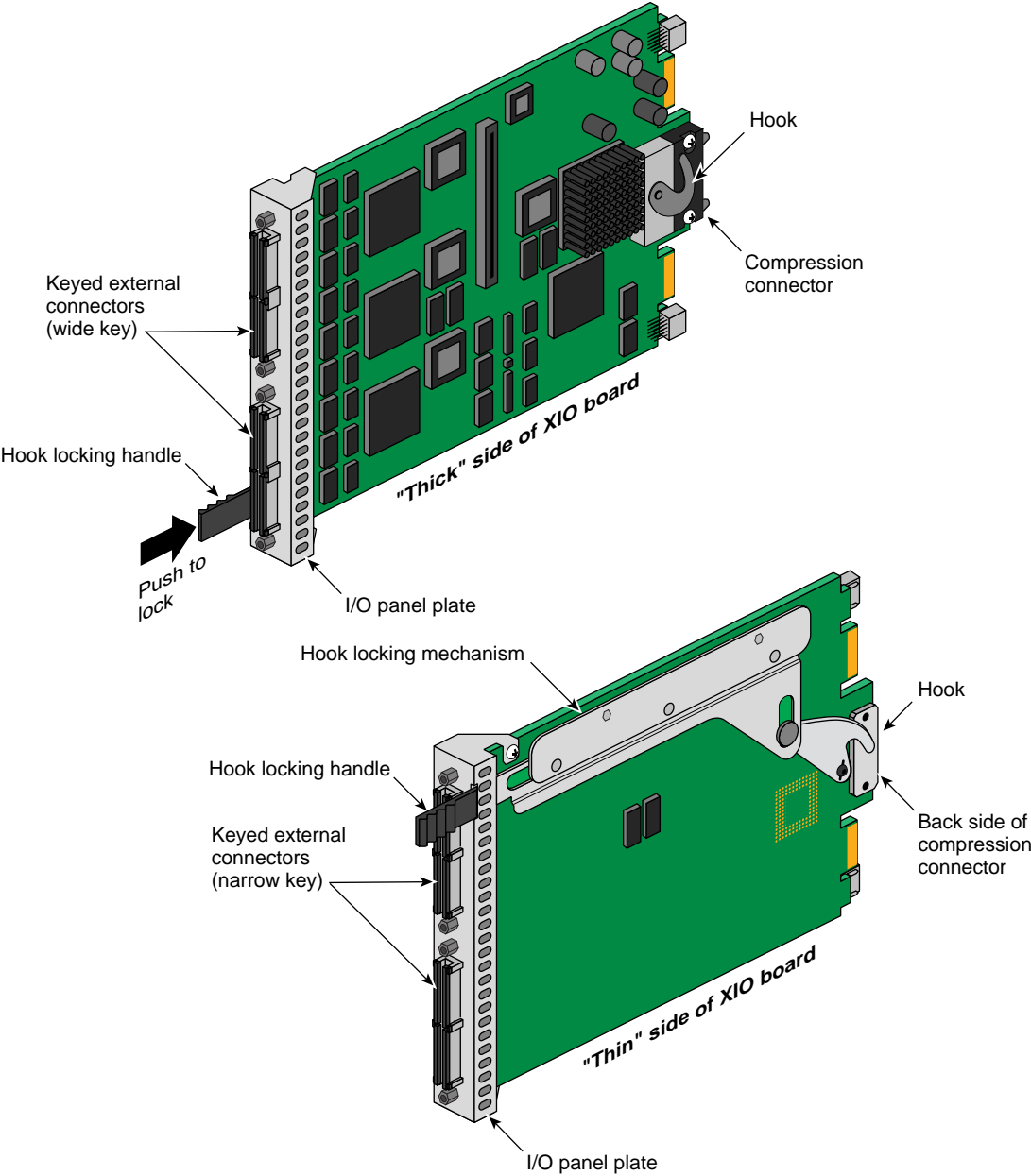

Figure 1-1 Ultra SCSI XIO Board

Figure 1-2 diagrams the Ultra SCSI board.

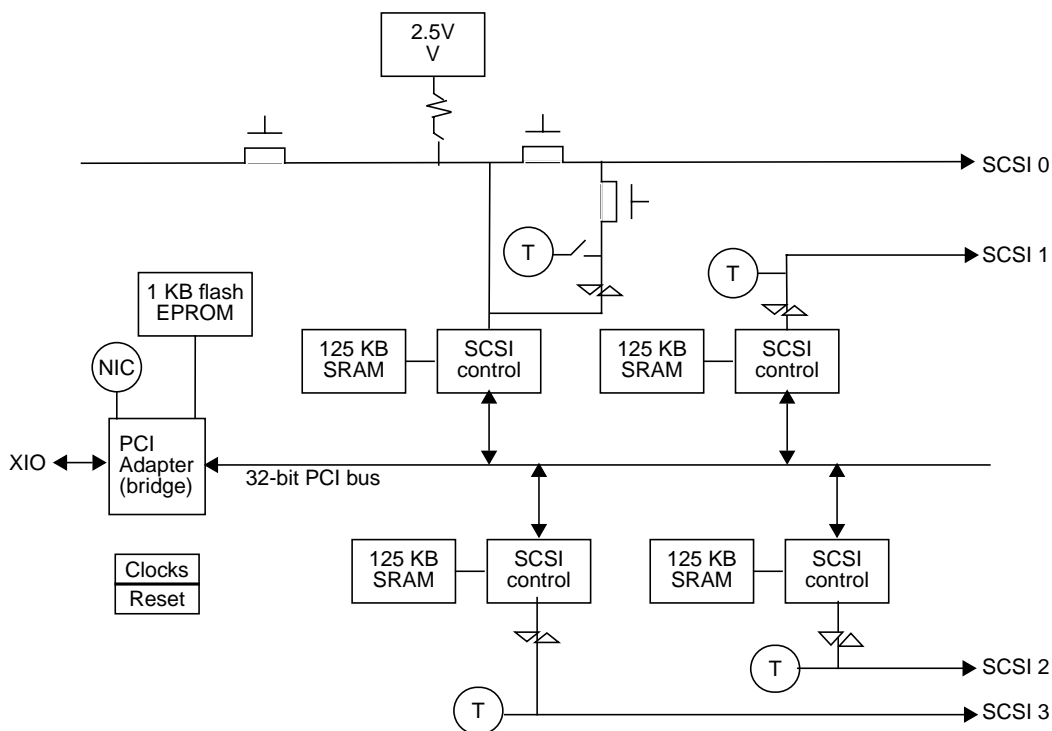

Figure 1-2 Ultra SCSI Board Diagram

1.2.1 Hook Actuator

For an XIO board to function, its compression connector must be locked tightly to a mate (other half) on the midplane or frontplane, inside the chassis. Each XIO board has two hooks (one on each side of the compression connector). A hook actuator presses against one of the hooks, thus moving the hooks into and out of their locked position. The hook actuator functions as follows:

- Pushing the handle locks the hooks and seats the compression connector to the midplane.
- Pulling the handle releases the hooks, in preparation for removing the board.

1.2.2 Compression Connector

The compression connector used for XIO boards has 96 pads that enable passage of signals between the system (via the midplane) and the XIO board. This compression connector has two halves: one half is physically located on the XIO board (illustrated in Figure 1-3); the other half is on the midplane of the chassis. Each pad on a midplane connector is a flat gold-plated surface. Each pad on an XIO board connector is composed of hundreds of tiny bristles (dendrites). When a bristled pad is pressed into a gold-plated pad, a connection is created for one signal.

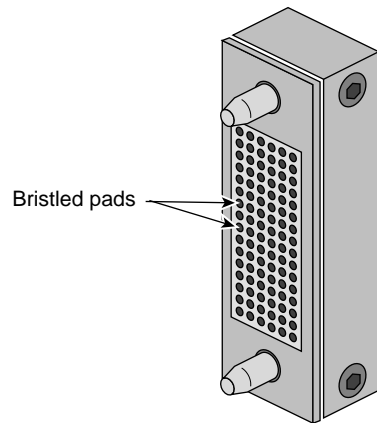

Figure 1-3 Ultra SCSI Board Compression Connector

1.2.2.1 Storing and Handling the Compression Connector

The bristled pads of the compression connector can attract and hold dust, lint, grease, powder, and dirt, which clogs or damages the bristles and prevents them from making proper contact with the gold-plated pads on the system's midplane.

To avoid damaging an XIO board's compression connector and to keep it in optimal working condition, follow these guidelines whenever the board is not installed:

Caution: Failure to follow these instructions can result in irreparable damage to the surface of the connector's pads, which may result in intermittent or complete failure of the product.

- Do not wipe or touch the pads of the compression connector with anything (no human fingers, no brushes, no cloth, no probes), except as specified in the cleaning instructions in "Cleaning the Compression Connector" in Chapter 3. The bristles might be damaged.
- Whenever the board is not in an XIO slot, put the protective cap over the compression connector and store the board in an antistatic bag. Make sure to close (fold over) the open end of the bag in order to minimize exposure to dust and atmospheric gases. Figure 1-4 shows the cap.

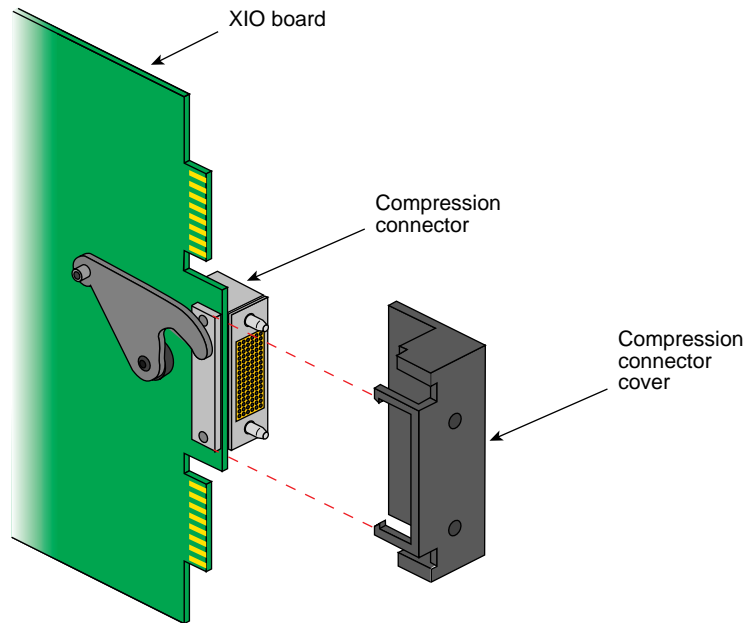

Figure 1-4 Compression Connector Protective Cover

- Do not put anything (not even water) onto the pads, except as specified in the cleaning instructions in Chapter 3, “Maintenance.”.
- Before laying the board down on a surface, make sure that the surface is free of dust, lint, powder, metal filings, oil, water, and so on.
- Do not blow dust, dirt, or powder anywhere near the board when it is not inside its protective bag.

1.3 Cables

Two Y cables included with the option connect the two double ports on the board to as many as four SCSI channels, as diagrammed in Figure 1-5.

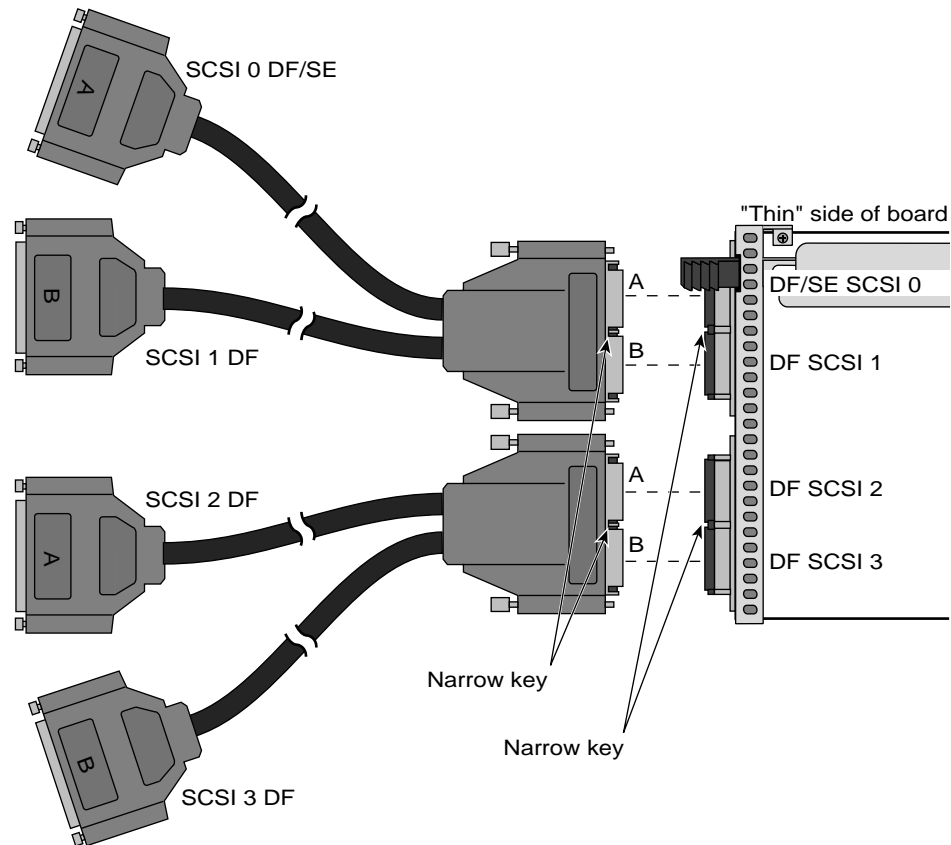

Figure 1-5 Ultra SCSI Board Connectors and Cables

The connectors are keyed to ensure correct insertion. Inserting the large high-density connectors incorrectly causes irreparable damage to them.

Labels included in the option are used to identify the module, XIO slot, and SCSI channel for each SCSI connector.

Chapter 2

Installing the Option

This chapter explains

- selecting an XIO slot for the Ultra SCSI board
- installing the Ultra SCSI option board
- cabling the Ultra SCSI board
- testing the new installation

2.1 Selecting an XIO Slot for the Ultra SCSI Board

This section explains

- I/O for Origin2000 and Onyx2 systems
- determining the available XIO slots
- Ultra SCSI board placement restrictions

2.1.1 I/O for Origin2000 and Onyx2 Systems

Figure 2-1 shows I/O in the Origin2000 deskside chassis.

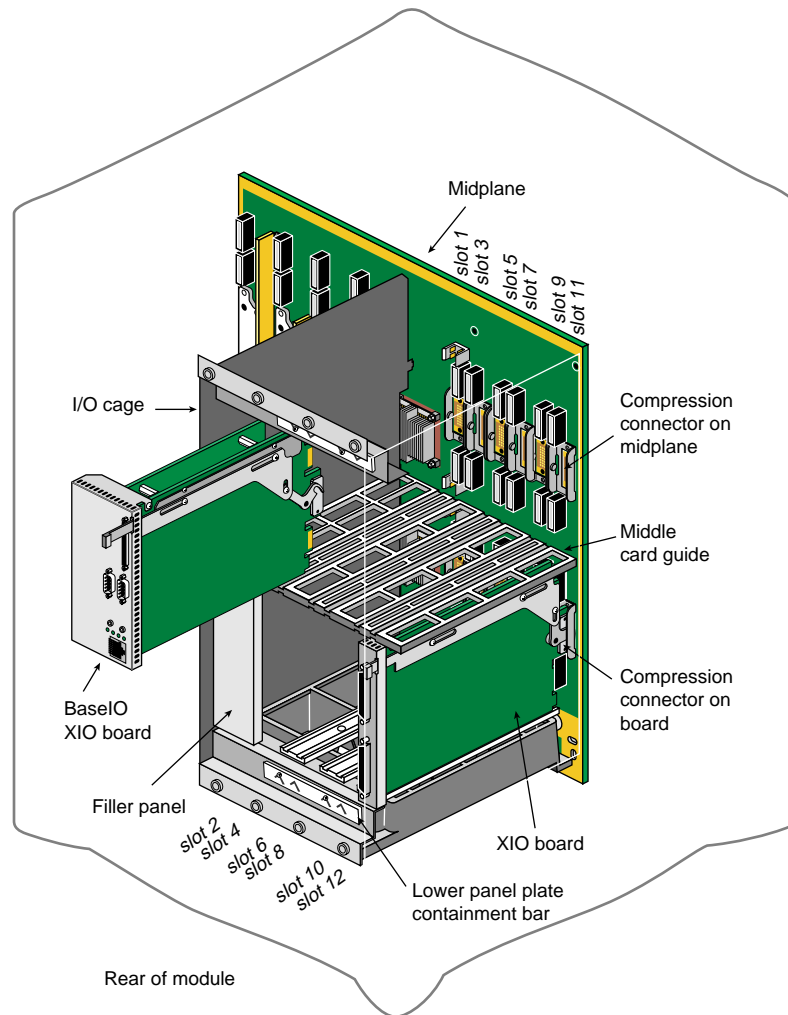

Figure 2-1 I/O in the Origin2000 Deskside Chassis

Figure 2-2 shows I/O in the Onyx2 deskside chassis.

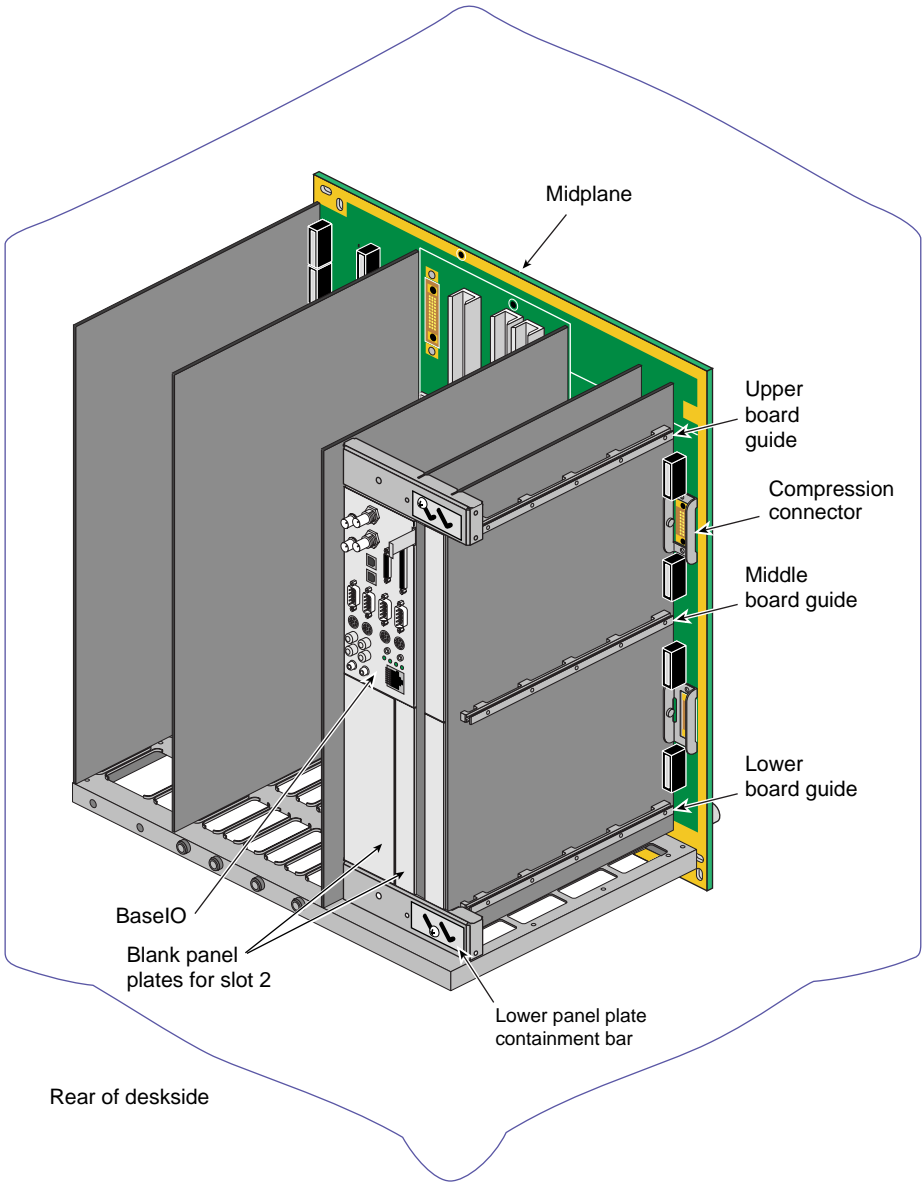

Figure 2-2 I/O in the Onyx2 Deskside Chassis

2.1.2 Determining the Available XIO Slots

In the Origin2000 and Onyx 2 systems, the number of installed Node boards determines the number of XIO slots that can be activated. If a system module has only one Node board, then only six of the 12 XIO slots are activated. When two Node boards are installed, all XIO slots can be activated, *if* the Node boards are positioned in the correct slots.

Figure 2-3 diagrams the Node board-to-XIO board correlation. The Node boards and their corresponding XIO board slots are indicated with either a circle or triangle. When Node 1 is present, IO slots 1 through 6 (designated by a circle) are activated. When Node 2 is also present, then IO slots 7 through 12 (designated by a triangle) are activated.

Node boards 3 and 4 also have corresponding XIO slots indicated by a circle or a triangle. For example, if Node boards are installed in slot 1 and slot 3, then only the corresponding XIO slots (1 through 6) are activated.

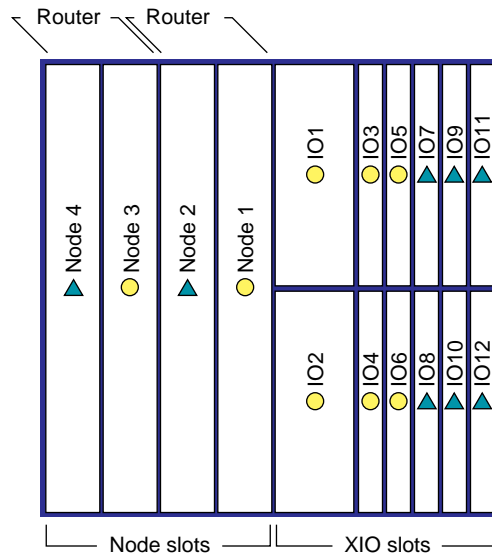

Figure 2-3 Board Configuration and Layout for System Module

In summary:

- If a module has a Node board in slot *N1* or *N3*, then XIO slots 1 through 6 are available.
- If it has a Node board in slot *N2* or *N4*, XIO slots 7 through 12 are available.
- If a module has two Node boards, one in *N1* or *N3* and one in *N2* or *N4*, then all 12 XIO slots are available.

Figure 2-4 diagrams the relationship between router boards, Node boards, and XIO boards.

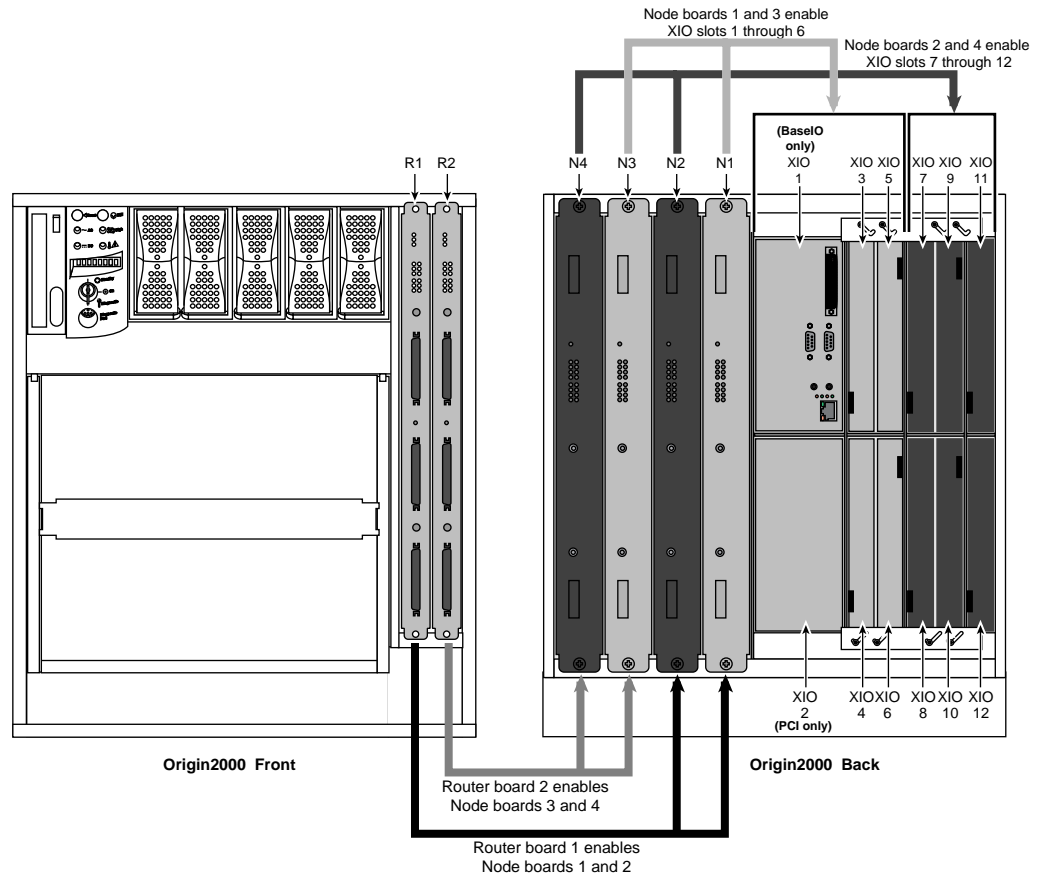

Figure 2-4 Router Board, Node Boards, and XIO Boards

Generally, plan to fill available odd-numbered XIO slots before filling even-numbered ones, and fill lower-numbered slots before higher-numbered ones. For example, fill XIO slot 3 before filling either slot 2 or slot 5, and fill slot 7 before slot 2.

2.1.3 Ultra SCSI Board Placement Restrictions

The following restrictions apply to Ultra SCSI board placement:

- Because of its compression connector type, the Ultra SCSI board cannot be inserted into slot 2 in any Origin2000 or Onyx2 system.
- In modules with no IO6 board, the Ultra SCSI board can go into slot 1, where it activates the internal SCSI channels for the module and enables the system's internal disk drives and CD-ROM drive to be used.
- The Onyx2 deskside system has a different board orientation scheme from the other three systems. You can install either three full-height boards or five half-height boards. Slot 4 combines with slot 3 to provide a full-height slot. You can install the Ultra SCSI board (a half-height board) into slot 3, but you cannot install it or any other half-height board into slot 4. (Also, the Ultra SCSI board cannot be used in XIO slot 2, as in the other systems.)

2.1.4 Planning Ultra SCSI Board Placement

To determine where to place the Ultra SCSI board, particularly in multi-module systems, follow the guidelines in these steps:

1. If you are installing the Ultra SCSI board into a system of interconnected racks, determine the rack and module into which you are going to install the board.
2. Consult with the customer to determine the SCSI devices to which the Ultra SCSI board is to be cabled, and which devices are to be on which SCSI channel.

Take into account the SCSI protocol (single-ended/differential, fast/slow) of each device for each channel; make sure the total bus length for each channel does not exceed limits summarized in Table 2-1.

Table 2-1 Maximum Cable Lengths for SCSI Options

SCSI Flavor	Channel	Maximum Cable Length
Differential Fast-20	0, 1, 2, 3	25 m
Differential Fast-10 wide	0, 1, 2, 3	25 m
Single-ended	0	6 m
Single-ended Fast-10	0	3 m
Single-ended Fast-20	0	1.5 m

3. If more than one module is to have Ultra SCSI boards, attach a peel-off label from the module label sheet to each module to identify it, consulting with the customer as necessary.
4. Select the XIO slot(s) into which the board(s) you are installing, following guidelines in “Selecting an XIO Slot for the Ultra SCSI Board,” earlier in this chapter.

2.2 Installing the Ultra SCSI Option Board

After you have selected a slot for each Ultra SCSI board you are installing, follow these steps:

1. Be familiar with the care and handling of XIO boards, particularly the compression connectors, as explained in Chapter 1.
2. If necessary, consult with the customer to bring down the system, making sure all users are off the system before proceeding.
3. Loosen the holding brackets (containment plates) that secure the XIO boards in place, and slide the bracket diagonally up or down to fully expose the board slots (see Figure 2-5).

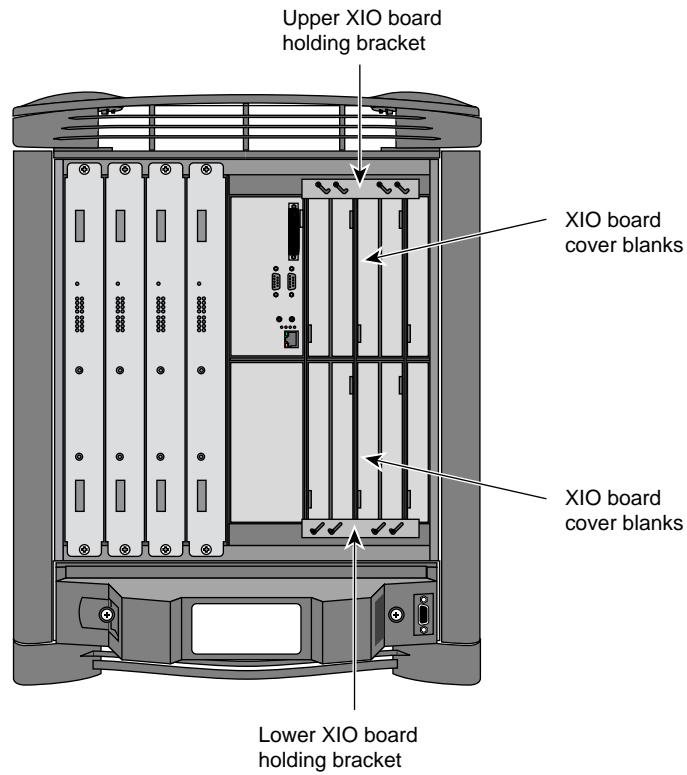

Figure 2-5 XIO Cardcage Holding Brackets and Cover Blanks

4. Remove the XIO cover blank as required (see Figure 2-5).

5. Remove the protective cover from the board's compression connector, as illustrated in Figure 2-6. This cover must be stored to cover the compression connector if the board is removed for any reason.

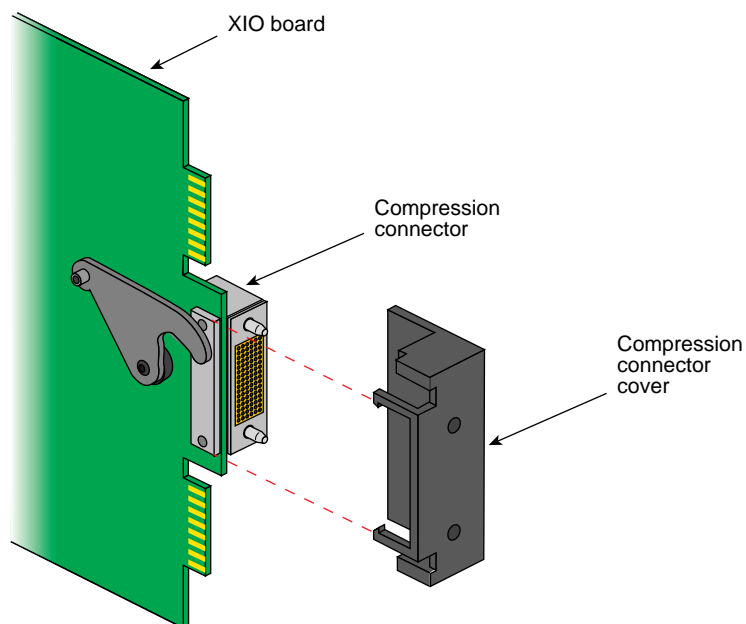

Figure 2-6 Removing the Protective Cover From the Compression Connector

6. Orient the board appropriately for the slot. For the Origin2000 systems and the Onyx2 rackmount, the XIO boards have a different installation orientation from slot to slot.
 - The thick side faces left for slots IO1/ IO2, IO5/IO6, and IO9/IO10.
 - The thick side faces right for slots IO3/IO4, IO7/IO8, and IO11/IO12.

Figure 2-7 diagrams this arrangement for Onyx2 rackmount and for Origin2000 deskside and rackmount systems.

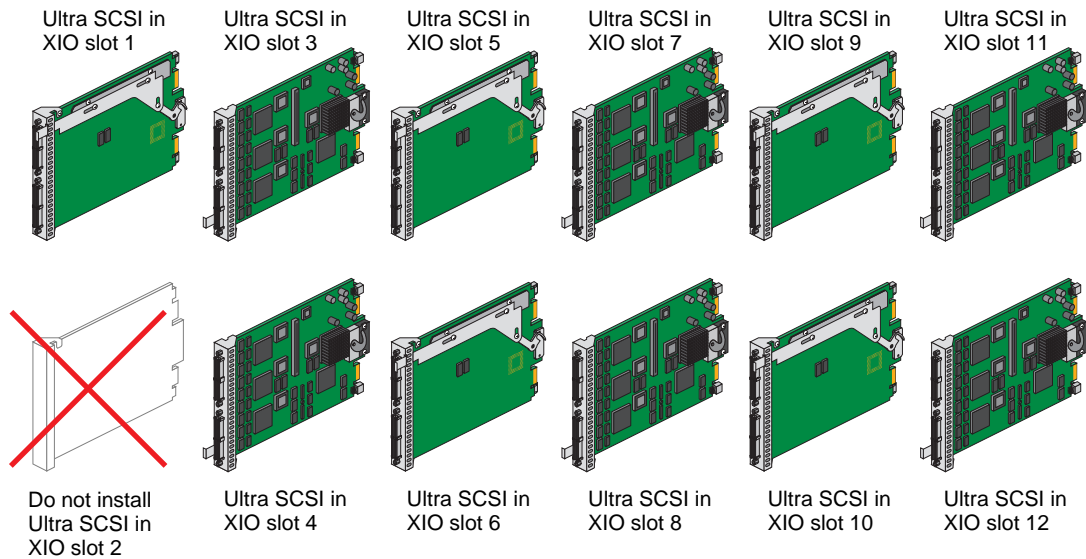

Figure 2-7 Ultra SCSI Board Orientation (Origin2000 Systems and Onyx2 Rackmount)

Note: Because of its compression connector type, the Ultra SCSI board cannot be inserted into slot 2. In modules with no BaseIO board, the Ultra SCSI board can go into slot 1, where it activates the internal SCSI channels for the module.

The Onyx2 deskside system has a different board orientation scheme (see Figure 2-8).

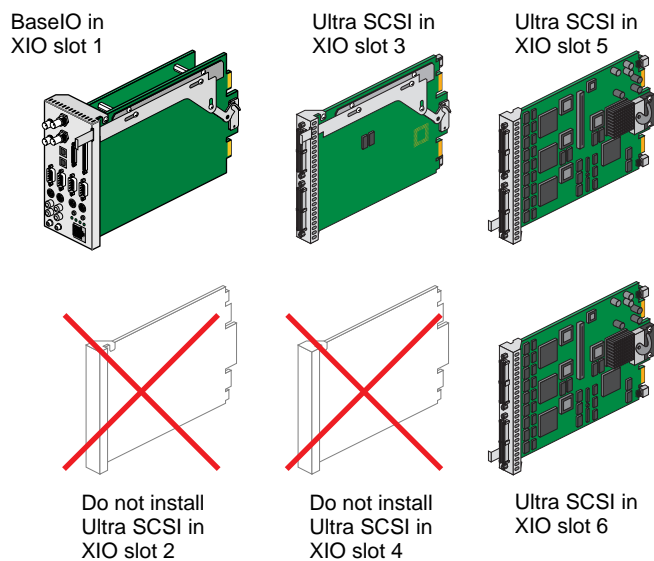

Figure 2-8 Ultra SCSI Board Orientation (Onyx2 Deskside)

Note: The Ultra SCSI board cannot be inserted into Onyx2 deskside XIO slots 2 or 4.

7. Position the board between the card guides and slide it into the chassis.

Caution: Take care that no board components are damaged as you slide the board past other XIO boards in the chassis.

- Verify that the board's panel plate is flush with the other panel plates. If it is not flush, check that the board is properly positioned between the card guides, and then press gently until it is flush. The board snaps into place.

Caution: Do not use force to seat the board; thumb pressure should suffice. If the board hangs an inch before going in all the way, work (wiggle) it gently so that it mates with the connectors on the midplane.

- When the board is in place, push the hook actuator handle forward as shown in Figure 2-9 to engage the compression connector.

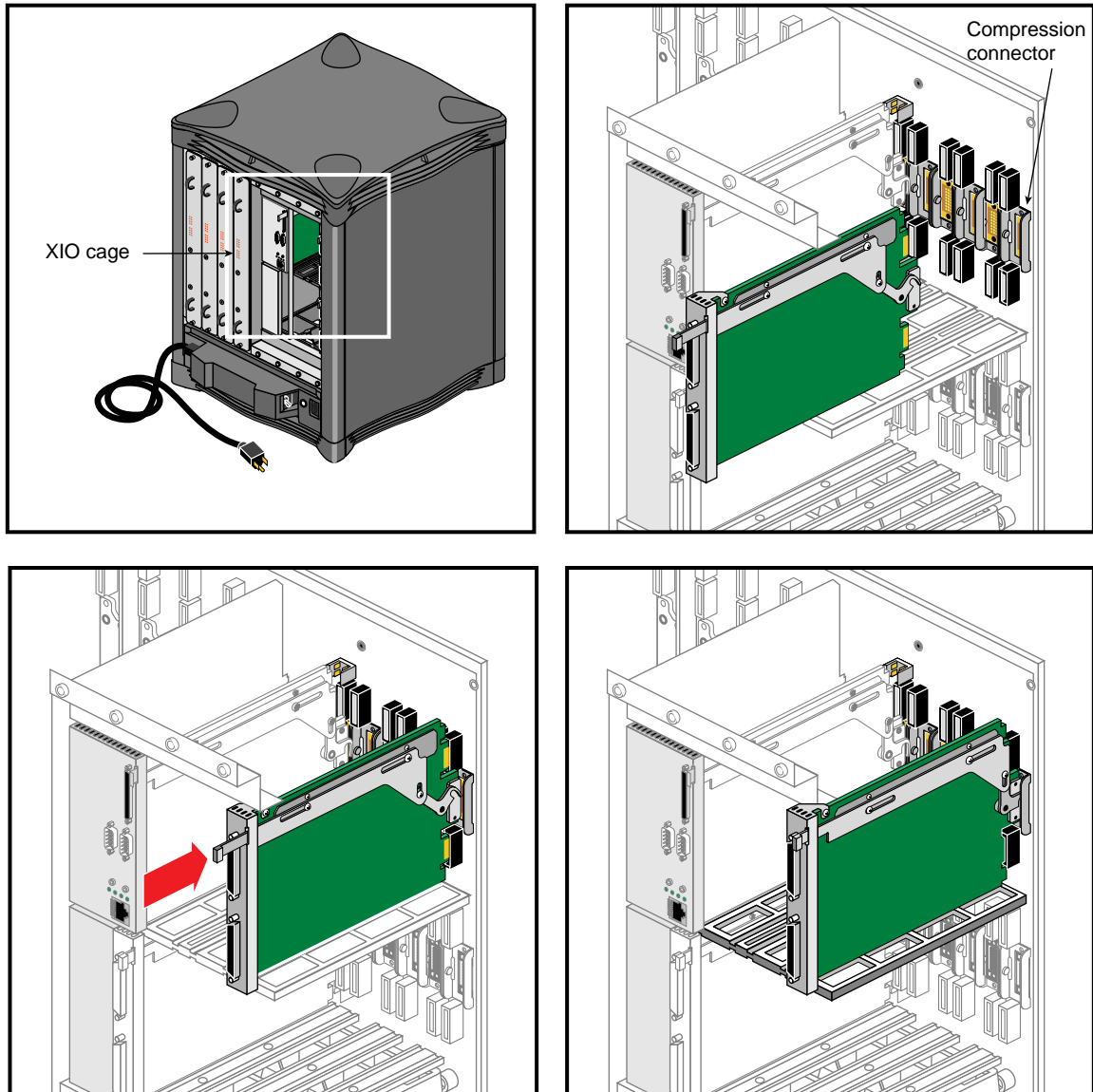

Figure 2-9 Installing the Ultra SCSI Board

- Install additional Ultra SCSI boards, if the customer has ordered them.

11. Secure the Ultra SCSI board(s) in place using the holding brackets (containment plates; see Figure 2-5). Slide the bracket diagonally up or down to hold the board in place in the cardcage.
12. Repeat the steps in this section for other modules if necessary.

2.3 Cabling the Ultra SCSI Board

For systems with more than one module or with more than one Ultra SCSI board installed in a module, label sheets are provided to help keep straight which device is connected to which SCSI channel on which XIO slot in which module. One type of label sheet has module numbers (for example, **MOD 1**); the other type has XIO slot and SCSI channel numbers (for example, **IO1 SCSI0**).

As you cable the devices to the Ultra SCSI board, you attach a slot/channel label to each end of each leg of each Y cable, and to each end of any additional cables needed to connect to the target SCSI device. In a multi-module system, you also attach a module label to each cable end as well.

To attach the cables, follow these steps:

1. Locate the peripheral devices to which the Ultra SCSI board is to interface. Consult with the customer as to which devices are to be on which SCSI channel.
2. Have ready both types of label sheets (module and XIO slot/SCSI channel). In systems with Ultra SCSI boards installed in more than one module, label each module with a peel-off sticker from the module label sheet, if you have not already done so.
3. Orient the high-density (double) connector to plug into the 0/1 port on the Ultra SCSI board. If the Ultra SCSI board hook actuator handle is at the top of the board, orient the high-density connector so that the letter **A** (molded into the plastic on the wide-keyed side) is on top. If the Ultra SCSI board hook actuator handle is at the bottom of the board, orient the connector so that the letter **B** is on top.

Caution: The high-density cable connectors that plug into the board ports are keyed; if they are inserted incorrectly, the cable connector is destroyed, and the system does not see the bus and the devices on it.

4. Plug the connector into the 0/1 port on the Ultra SCSI board; see Figure 2-10.

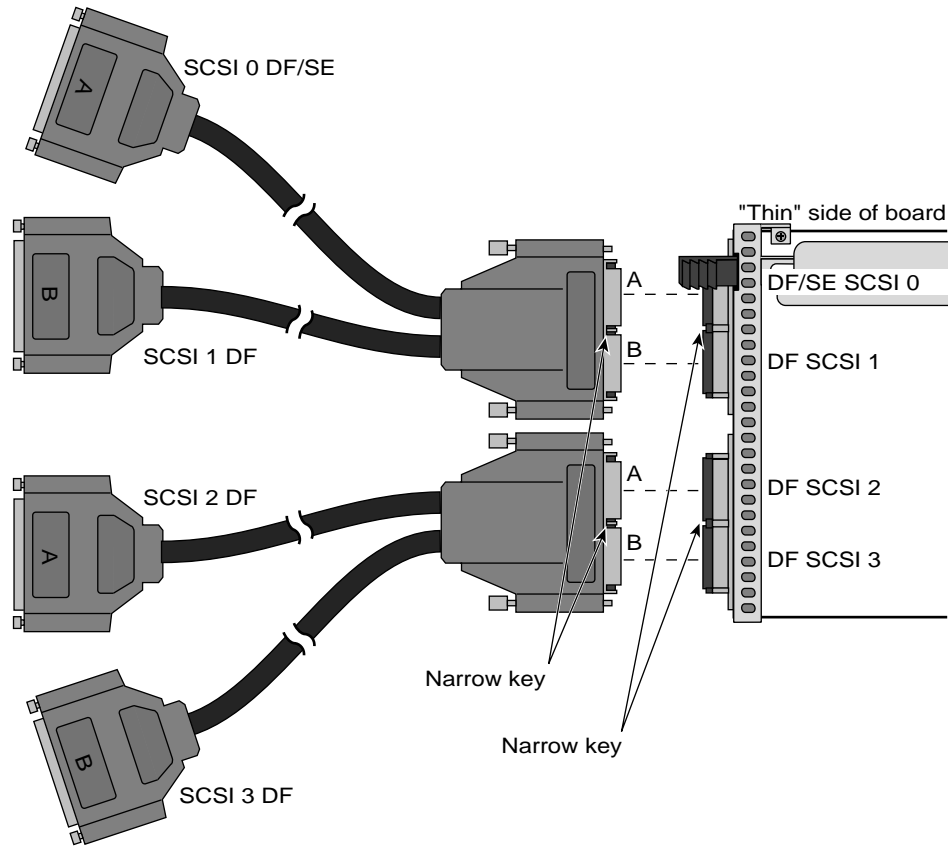

Figure 2-10 Ultra SCSI Board Connectors and Cables

5. Affix labels to each leg of the Y cable at the high-density connector end so that the labels can be easily read when the system is fully configured:
 - an XIO slot/SCSI channel label to identify the XIO slot the board occupies and the SCSI channel carried on this cable
 - in multi-module systems, a module label

For example, the Y cable plugged into SCSI channels 0/1 of an Ultra SCSI board in XIO slot 3 in the first module of a multi-module system has these labels:

- first leg of Y cable: **MOD 1** and **IO3 SCSI0**
- second leg of Y cable: **MOD 1** and **IO3 SCSI1**

6. For a rackmount system, use the XIO cable management guide to route, track, and protect the associated board cables (see Figure 2-11). To do so, remove the securing band to open a guide slot and flip open the slot tab.

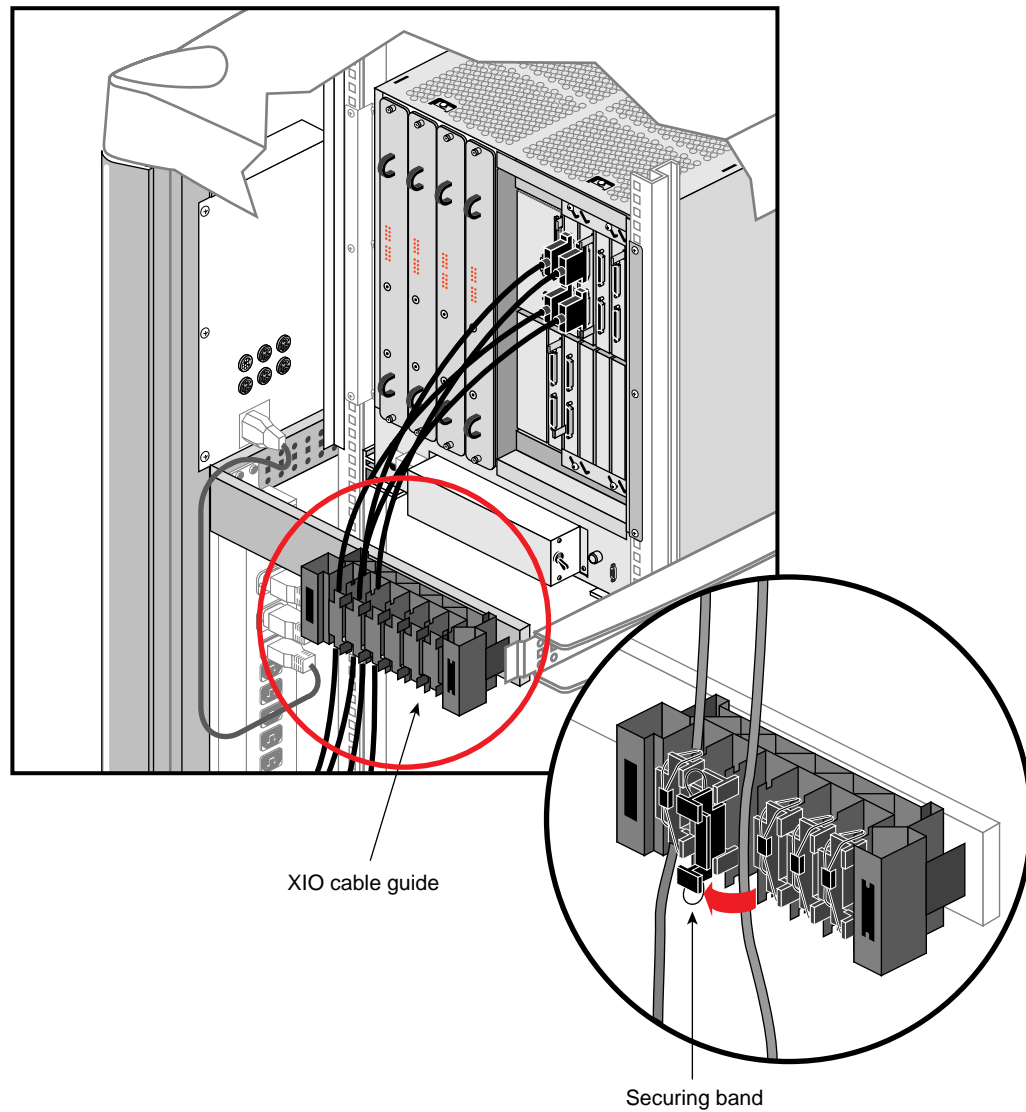

Figure 2-11 XIO Cable Guide (Rackmount System Only)

Insert the cable into the guide slot, close the slot tab, and reattach the securing band to keep the cable in place.

7. Attach the other end of the cable to the appropriate SCSI device(s). See Figure 2-12.

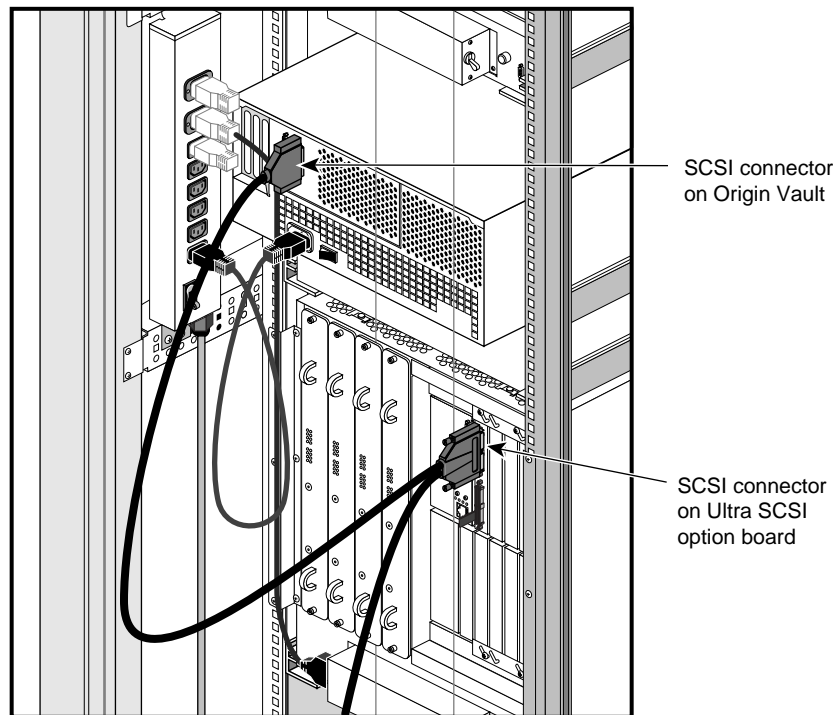

Figure 2-12 Attaching an Ultra SCSI Cable

8. Affix a slot/channel label and, if necessary, a module label to the cable near the P connector so that the labels can be easily read when the system is fully configured.
If an additional cable is used to connect to the peripheral, affix a label to that cable.
9. Attach and label the Y cable's other P connector as appropriate.
10. If devices are to be cabled to channel 2, 3, or both, attach and label the cables as appropriate.

2.4 Testing the New Installation

To make sure that the system sees the board and attached peripherals, run the hardware graph listing, giving the specific module, Node board slot, node, and XIO slot. For example:

```
# ls /hw/module/1/slot/n1/node/xtalk
```

The following output example shows an XIO board in XIO slot 14.

```
14
```

Use the `-l` option for more detail about the option; for example:

```
# ls -l /hw/module/1/slot/n1/node/xtalk
```

The following is a possible output, showing slot 14 linked to an Ultra SCSI option board entry

```
drwxr-xr-x    0 root    sys          0 Mar 14 17:36 0
lrw-----    0 root    sys          28 Mar 14 17:36 14 ->
/hw/module/3/slot/io5/m SCSI
```

Use the hardware graph listing to determine if the system sees the SCSI devices to which the Ultra SCSI board is cabled. For more information, see the *Origin2000 and Onyx2 Deskside and Rackmount Installation Instructions*. You can also use *hinvt* to check the number of system controllers and devices.

Chapter 3

Maintenance

This chapter describes

- removing an Ultra SCSI board
- cleaning the compression connector

3.1 Removing the Ultra SCSI Option Board

To remove an Ultra SCSI board, follow these steps:

1. Make sure all users are off the affected systems.
2. Have ready an antistatic surface or packaging for the board. Have ready the compression connector cover and an XIO slot cover.
3. At the back of the chassis, detach all I/O cables for the Ultra SCSI boards you are removing. If necessary, attach labels or make a diagram to prevent wrong connections when the system is recabled. For a rackmount system, remove the securing bands that hold the cables in place.

4. Loosen the holding brackets that secure the XIO boards in place, and slide the bracket diagonally up or down (see Figure 3-1).

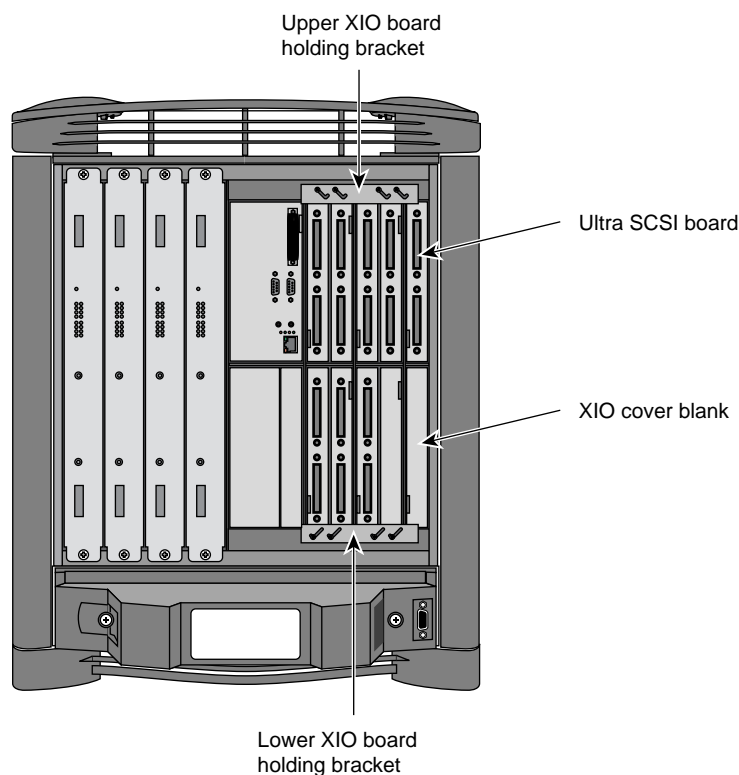

Figure 3-1 XIO Cardcage Holding Brackets and Cover Blanks

5. Pull out the hook actuator handle on the Ultra SCSI board to disengage the compression connector and gently pull the board out from the system.

Caution: Take care that no board components are damaged as you move the carrier past other XIO boards in the cage.

6. Attach the compression connector cap and package the board.
7. Replace the XIO slot cover.

3.2 Cleaning the Compression Connector

A compression connector should never need to be cleaned, if you keep the protective cover on whenever the XIO board is not installed.

Note: Some pollutants can irreversibly damage (corrode or chemically alter) the pad surfaces. Although cleaning may remove the pollutant, it will not repair damage incurred by this contact.

To remove pollutants, follow these instructions:

1. Obtain a can of dry, compressed inert gas (for example, 100% pure nitrogen).

Warning: Do not use a cleaning product that contains any of the following ingredients: halogenated hydrocarbons, aromatic hydrocarbons, ethers, sulphur, ketones, or solvents of any kind. These substances will cause irreparable damage to the connector's surface.

2. Prepare the can for use as instructed on the can. For example, attach the spray tube, if provided, to the can's dispensing mechanism.
3. Remove the compression connector cap. Hold the can so that the tip of the applicator is 1 to 2 inches away from the first row of pads at the topmost edge of the connector (as illustrated in Figure 3-2) and at a slight angle so that the spray hits each pad and flows downward. You will be spraying at the pads on one row but in the direction of the next row of pads. Do not allow the applicator to touch the pads.

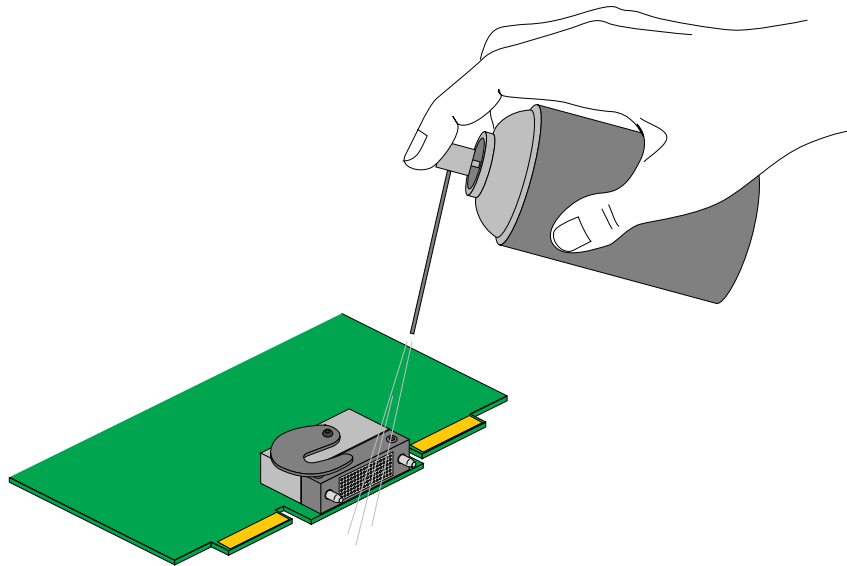

Figure 3-2 Cleaning the Compression Connector

4. Spray, moving the spray along the side of the connector until the entire first row has been sprayed. Move down (to the next row). Repeat until all the pads have been sprayed.
5. Replace the compression connector cap.

Appendix A

Ultra SCSI P Connector Pinouts

Table A-1 lists pinouts for the 68-pin standard differential (wide bus) SCSI connectors on the Ultra SCSI cables.

Table A-1 Ultra SCSI P Connector Pinouts

Signal Name	Pin Number	Pin Number	Signal Name
+DB(12)	1	35	-DB(12)
+DB(13)	2	36	-DB(13)
+DB(14)	3	37	-DB(14)
+DB(15)	4	38	-DB(15)
+DPARH	5	39	-DPARH
+Ground	6	40	-Ground
+D0	7	41	-D0
+D1	8	42	-D1
+D2	9	43	-D2
+D3	10	44	-D3
+D4	11	45	-D4
+D5	12	46	-D5
+D6	13	47	-D6
+D7	14	48	-D7
+DPAR	15	49	-DPAR
DIFFSENS	16	50	Ground
TERMPWR	17	51	TERMPWR
TERMPWR	18	52	TERMPWR
Reserved	19	53	Reserved
+ATN	20	54	-ATN
Ground	21	55	Ground
+BSY	22	56	-BSY
+ACK	23	57	-ACK
+RST	24	58	-RST
+MSG	25	59	-MSG
+SEL	26	60	-SEL
+C/D	27	61	-C/D
+REQ	28	62	-REQ
+I/O	29	63	-I/O
Ground	30	64	Ground
+DB(8)	31	65	-DB(8)
+DB(9)	32	66	-DB(9)
+DB(10)	33	67	-DB(10)
+DB(11)	34	68	-DB(11)

