

Triple Keyboard Option for Infinite Reality Installation Instructions

Document Number 108-0150-001

Contributors

Written by Eric Zamost, based on previous work by Carolyn Curtis

Illustrated by Dan Young and Cheri Brown

Edited by Christina Cary

Production by Cindy Stief

Contributions by Gordon Elder, Robert Keller, Reuel Nash, Suzanne Jones, Paul Everhardt, Susan Tellep, and Todd Longbottom.

© Copyright 1996, Silicon Graphics, Inc.— All Rights Reserved

This document contains proprietary and confidential information of Silicon Graphics, Inc. The contents of this document may not be disclosed to third parties, copied, or duplicated in any form, in whole or in part, without the prior written permission of Silicon Graphics, Inc.

Restricted Rights Legend

Use, duplication, or disclosure of the technical data contained in this document by the Government is subject to restrictions as set forth in subdivision (c) (1) (ii) of the Rights in Technical Data and Computer Software clause at DFARS 52.227-7013 and/or in similar or successor clauses in the FAR, or in the DOD or NASA FAR Supplement. Unpublished rights reserved under the Copyright Laws of the United States. Contractor/manufacturer is Silicon Graphics, Inc., 2011 N. Shoreline Blvd., Mountain View, CA 94043-1389.

Silicon Graphics and IRIS are registered trademarks and IRIX, CHALLENGE, Onyx, RealityEngine² and InfiniteReality are trademarks of Silicon Graphics, Inc.

FCC Warning

This equipment has been tested and found compliant with the limits for a Class A digital device, pursuant to Part 15 of the FCC rules. These limits are designed to provide reasonable protection against harmful interference when the equipment is operated in a commercial environment. This equipment generates, uses, and can radiate radio frequency energy and, if not installed and used in accordance with the instruction manual, may cause harmful interference to radio communications. Operation of this equipment in a residential area is likely to cause harmful interference in which case the user will be required to correct the interference at his or her own expense.

Attention

This product requires the use of external shielded cables in order to maintain compliance pursuant to Part 15 of the FCC Rules.

**Triple Keyboard Option for Infinite Reality Installation Instructions
Document Number 108-0150-001**

**Silicon Graphics, Inc.
Mountain View, California**

Contents

	About These Instructions	ix
1.	Triple Keyboard Option Kit Contents	1-1
2.	Installing the Triple Keyboard Option	2-1
2.1	Preparing the Chassis.....	2-2
2.2	Attaching the IO4 Daughtercards and Installing the IO4 Boards.....	2-4
2.3	Attaching TKO Panels to the I/O Doors	2-5
2.4	Attaching Ribbon Cables	2-7
2.5	Cabling the Keyboards and Monitors.....	2-8
2.6	Cabling Serial Ports	2-9
2.7	Creating Input Devices.....	2-11
2.8	Setting up IRIX for the Triple-Keyboard Option.....	2-11
2.9	Configuring the Triple-Keyboard Option	2-12
2.10	Testing the New Installation	2-12

Figures

Figure 1-1	TKO Kit Contents.....	1-2
Figure 2-1	TKO I/O Filter Panel Example Slot Placement	2-2
Figure 2-2	Diagram of TKO Installation.....	2-3
Figure 2-3	Attaching the Daughtercard to an IO4	2-4
Figure 2-4	Labeling Filter Panels	2-5
Figure 2-5	Installing TKO Filter Panels	2-6
Figure 2-6	Installing Ribbon Cables	2-7
Figure 2-7	Attaching TKO External Cables.....	2-8
Figure 2-8	Serial Port Usage	2-10

Tables

Table 1-1	TKO Kit Component Part Numbers and Quantities	1-3
Table 2-1	Filter Panel Cabling	2-5
Table 2-2	Cabling Keyboards for TKO	2-8
Table 2-3	Serial Port Correspondences	2-9

About These Instructions

The Triple Keyboard Option (TKO) allows the connection of one or two additional keyboards to a Silicon Graphics Onyx™ rackmount system equipped with two or three InfiniteReality™ graphics pipes.

Note: This document is intended for use only by Silicon Graphics® System Support Engineers.

The Triple Keyboard Option consists of

- two daughtercards, one each for the second and third IO4 boards in the Onyx
- two filterboards, each attached to an I/O panel to be mounted on the Onyx I/O door; each panel provides two powered RS-232 peripheral ports, one RS-422 port, and a keyboard connector
- two keyboards, two mice, and their external cables
- external extension cables for monitors and keyboards/mice

Note: The TKO for InfiniteReality works with the base version of IRIX 6.2. No operating system upgrade is required for this installation.

Structure of This Document

The *Triple Keyboard Option Installation Instructions* consists of the following chapters:

Chapter 1 “Kit Contents” depicts and describes all TKO components.

Chapter 2 “Installing the Option” describes and illustrates how to install the TKO.

Conventions

In command syntax descriptions and examples, square brackets ([]) surrounding an argument indicate an optional argument. Variable parameters are in *italics*. Replace these variables with the appropriate string or value.

In text descriptions, IRIX filenames are in *italics*. The names of keyboard keys are printed in boldface typewriter font and enclosed in angle brackets, such as <Enter> or <Esc>.

Messages and prompts that appear onscreen are shown in typewriter font. Entries that are to be typed exactly as shown are in boldface typewriter font.

Chapter 1

Triple Keyboard Option Kit Contents

This chapter summarizes the contents of the Triple Keyboard Option (TKO) kit (marketing code HU-TKO). Figure 1-1 shows all TKO components.

Note: If parts are missing or if the kit contains incorrect parts, log a call with TAC.

Filterboard/panel assemblies

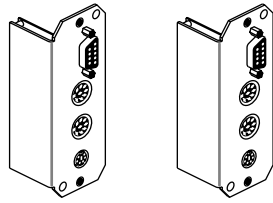

IO4 daughtercards

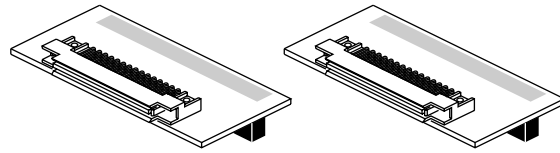

Keyboard/mouse assemblies

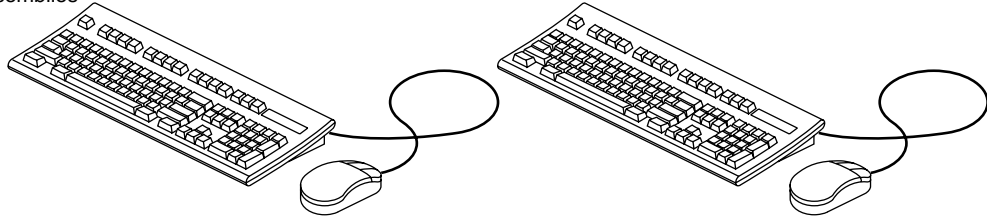

Keyboard auxiliary ribbon cables

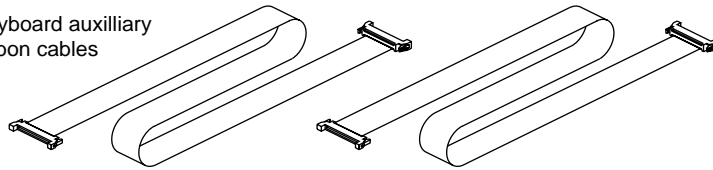

Video extension cables

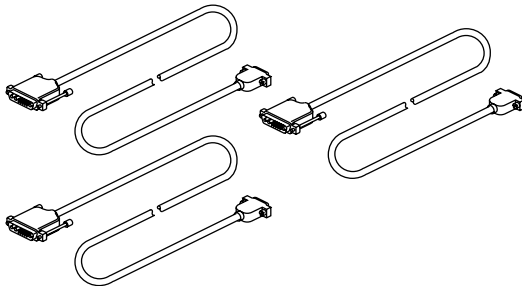

24W7 cables
(not used in IR)

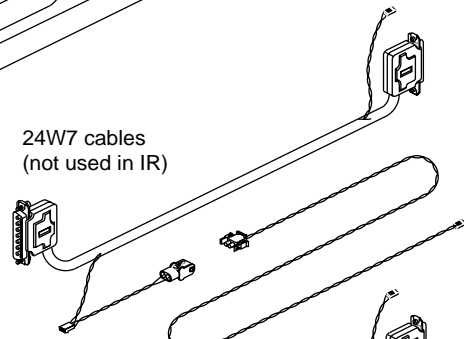

Jumper cable
(not used in IR)

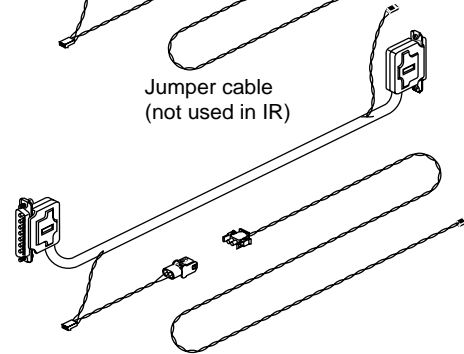

Keyboard/mouse extension cables

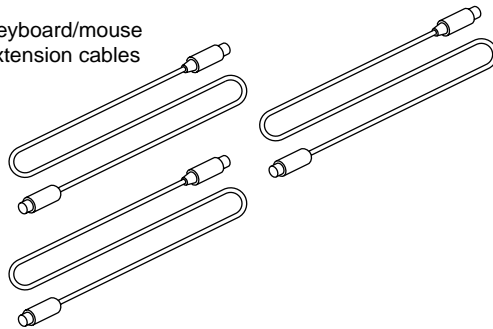

Label sheet

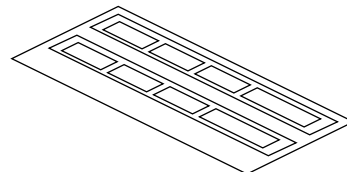

Figure 1-1 TKO Kit Contents

Table 1-1 lists part numbers and quantities for TKO components.

Table 1-1 TKO Kit Component Part Numbers and Quantities

Component	Part Number	Quantity
TKO for Infinite Reality Inst. Instructions	108-xxxx-001	1
TKO Inst. Instructions (for RealityEngine ²)	108-0125-001	1
Daughtercard (PCB ASSY, IO4 Adapter)	030-0340-002	2
TKO filterboard/panel assembly	013-1017-001	2
Keyboard auxiliary ribbon cable	018-0480-001	2
Keyboard/mouse assembly	013-0657-001	2
75-foot video and keyboard extension cables, marketing code X8-VKC1, includes		3
Extension cable for keyboard/mouse	018-8095-002	
Extension cable for video	018-8094-002	
Label sheet for I/O panel plates	024-0860-001	1
NOT USED: Modified 24W7 cables	018-0482-001	2
NOT USED: Jumper cable (black & white twisted)	018-0485-001	2

Note the following:

- The TKO kit contains some cables which are used only for RealityEngine² installations (see Figure 1-1 and Table 1-1 for details). When the TKO option is installed in an InfiniteReality system, these cables may be discarded.
- A third IO4 is required for the third keyboard. Since a third IO4 is already required for the third graphics pipe, this should not be an issue.

Chapter 2

Installing the Triple Keyboard Option

This chapter describes how to install the Triple Keyboard Option (TKO) in an InfiniteReality (IR) chassis. The installation procedure is divided into the following steps:

1. Preparing the chassis
2. Attaching the IO4 daughtercards
3. Installing the TKO filter panels on the cardcage 2 I/O door
4. Attaching the ribbon cables
5. Cabling the keyboards
6. Cabling the serial ports
7. Restarting the system
8. Configuring the TKO
9. Testing the new installation

Other Silicon Graphics manuals contain instructions for exchanging circuit boards. Make sure you have the appropriate one(s):

- *CHALLENGE™/Onyx Rackmount Installation Instructions* (108-7042-xxx)
- *CHALLENGE and Onyx Retrofit Instructions* (domestic version: 802-0107-002; international version: 802-0106-002)
- *Challenge/Onyx Rackmount Third Cardcage (CC3) Upgrade Instructions* (release note, 802-0105-xxx)

Make sure you have other pertinent release notes and Field Information Bulletins as well.

You need a flat-blade screwdriver and a Phillips screwdriver to install TKO.

2.1 Preparing the Chassis

Caution: Board components are extremely sensitive to electrostatic discharge. Use proper antistatic procedures while handling the board.

Before you install the option, follow these steps:

1. Make sure all users are off the target system. Gracefully shut down the system and open the chassis to expose the slots.
2. In order for the kernel to recognize the TKO option, the three IO4 boards must be in slots 11, 9, and 7 of cardcage 2. While the base IO4 board (board #0) will always be in slot 11, it is possible that the additional boards (board #1 and board #2) will need to be moved.

A processor board, existing options, or both might have to be moved to allow the additional IO4 boards to be placed in slots 9 and 7. For example, one of the processor boards or a memory board can be moved to cardcage 1 if it has an appropriate vacant slot.

3. The TKO's two panels are installed on the cardcage 2 I/O door; plan where to install them. To avoid interfering with removal of boards, they should not be installed in the bottom row of slots. Figure 2-1 diagrams this placement.

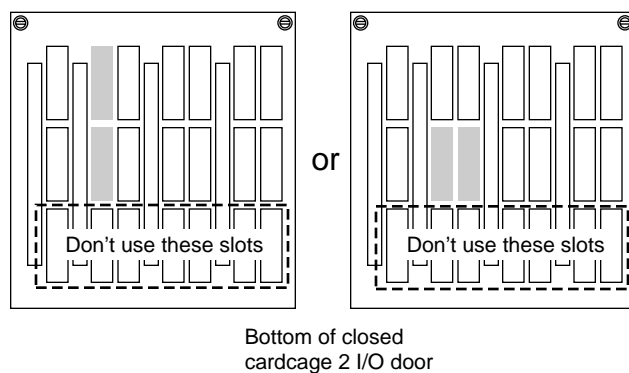

Figure 2-1 TKO I/O Filter Panel Example Slot Placement

Figure 2-2 diagrams a complete example installation.

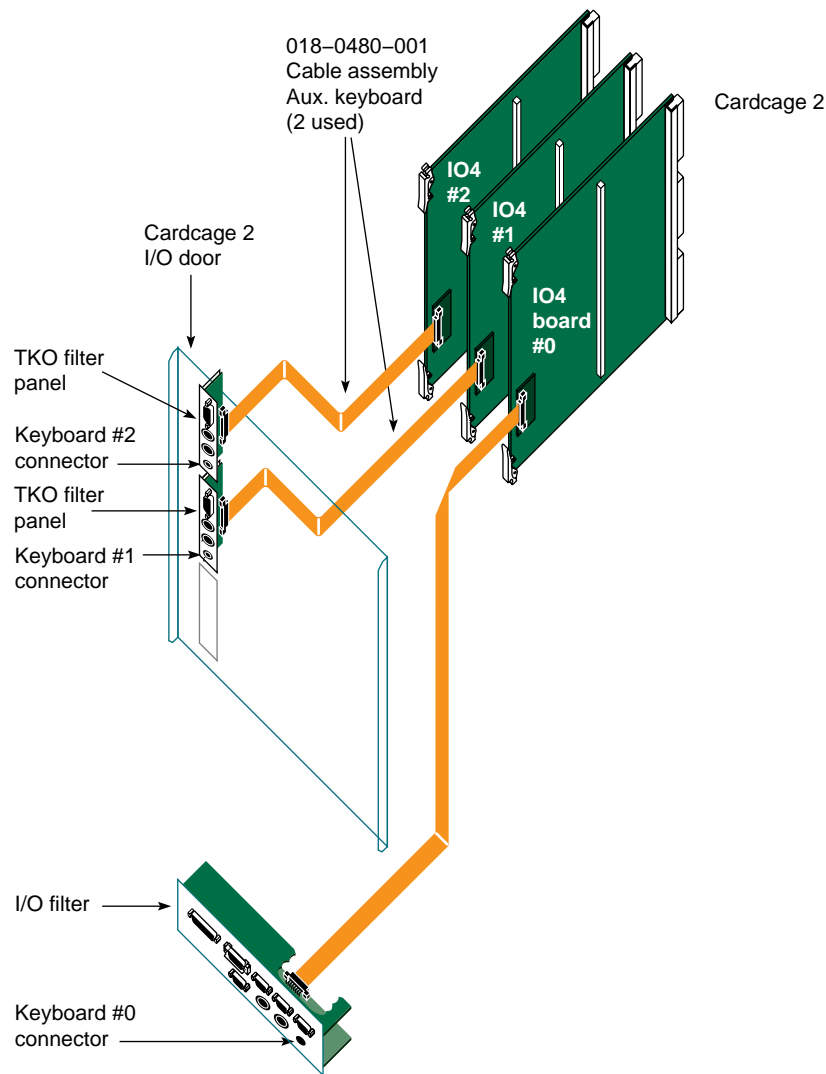

Figure 2-2 Diagram of TKO Installation

2.2 Attaching the IO4 Daughtercards and Installing the IO4 Boards

The TKO includes two daughtercards, one for each additional IO4 board in the system. To attach the daughtercards, follow these steps:

1. Remove the “second” IO4 board (board #1) from slot 9 in cardcage 2.
2. Attach one of the daughtercards to the small edge connector on the “second” IO4 board (the only edge connector that fits the daughtercard). The connector is located on the side farthest from the LEDs. See Figure 2-3.

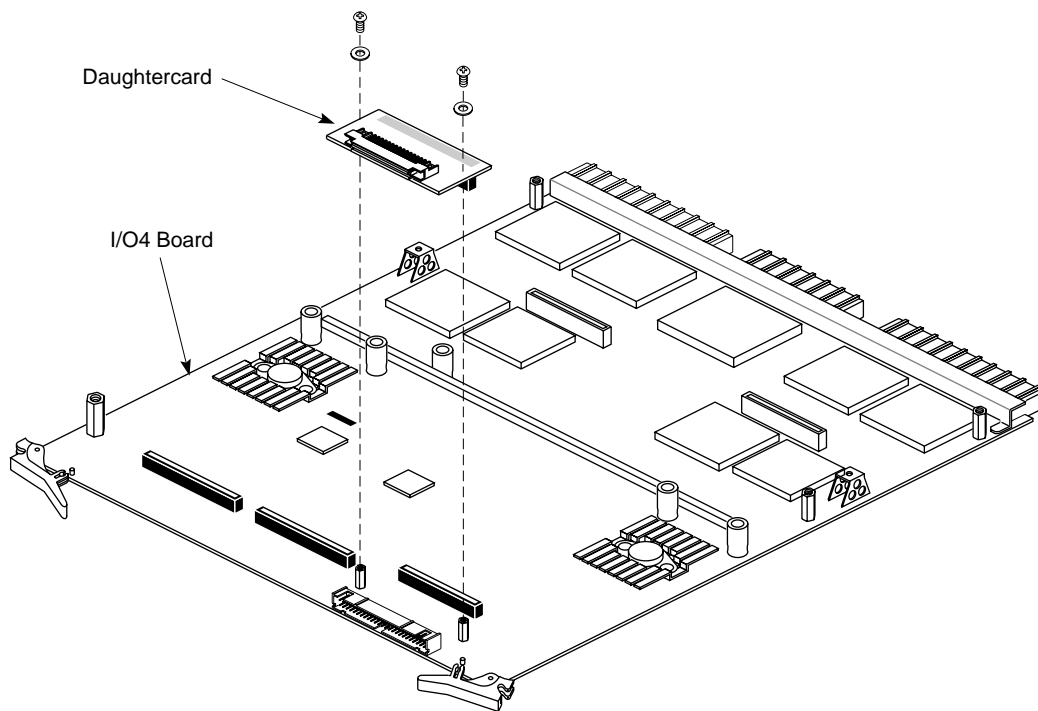

Figure 2-3 Attaching the Daughtercard to an IO4

3. Reinsert the IO4 you removed from the chassis into slot 9 in cardcage 2.
4. Remove the “third” IO4 board (board #2) from slot 7 in cardcage 2.
5. Attach the remaining daughtercard to the small edge connector on the “third” IO4 board as shown in Figure 2-3.
6. Reinsert the IO4 you removed from the chassis into slot 7 in cardcage 2.

2.3 Attaching TKO Panels to the I/O Doors

TKO I/O for the additional keyboards is handled on two filter panels installed on the cardcage 2 I/O door.

The filter panel assemblies themselves are identical, but must be differentiated by means of labels, because each filter panel is cabled to a specific IO4 and a specific graphics pipe, as outlined in Table 2-1. If necessary, refer to the layout diagrammed in Figure 2-2.

Table 2-1 Filter Panel Cabling

Filter Panel Label	To Be Cabled to IO4 (Ribbon Cable)	Associated with Graphics Head	Suggested Placement (Viewed with I/O Door Closed)
AUX KBD 1	#1 (“second”)	1 (cardcage 3)	Left or bottom
AUX KBD 2	#2 (“third”)	2 (cardcage 3)	Right or top

Follow these steps:

1. Attach a label to each filter panel. Figure 2-4 shows the position on the panel where the label should be applied.

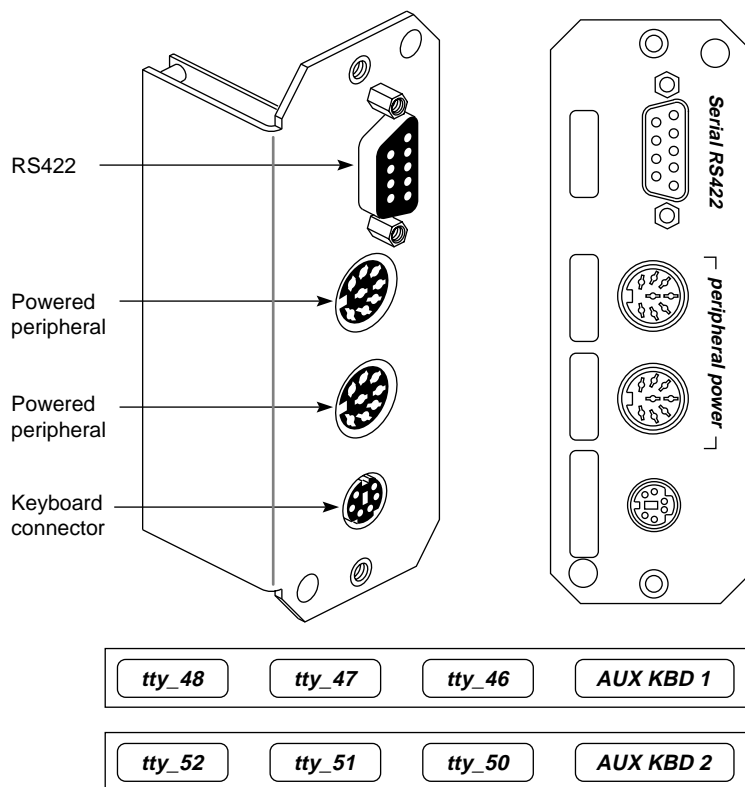

Figure 2-4 Labeling Filter Panels

2. On the cardcage 2 I/O door, remove the slot covers for the slots you have selected for the TKO I/O panels. Retain the screws.

Note: Do not use the bottom row of slots. Panels installed there make it difficult to remove boards.

3. Position the filter panel labeled **AUX KBD 1** on the bottom or left slot (as viewed with the I/O door closed); use the retained screws to mount it.
4. Position the filter panel labeled **AUX KBD 2** on the top or the right slot (as viewed with the I/O door closed) whose cover you have removed; use the retained screws to mount it. Figure 2-5 shows the filter panels installed.

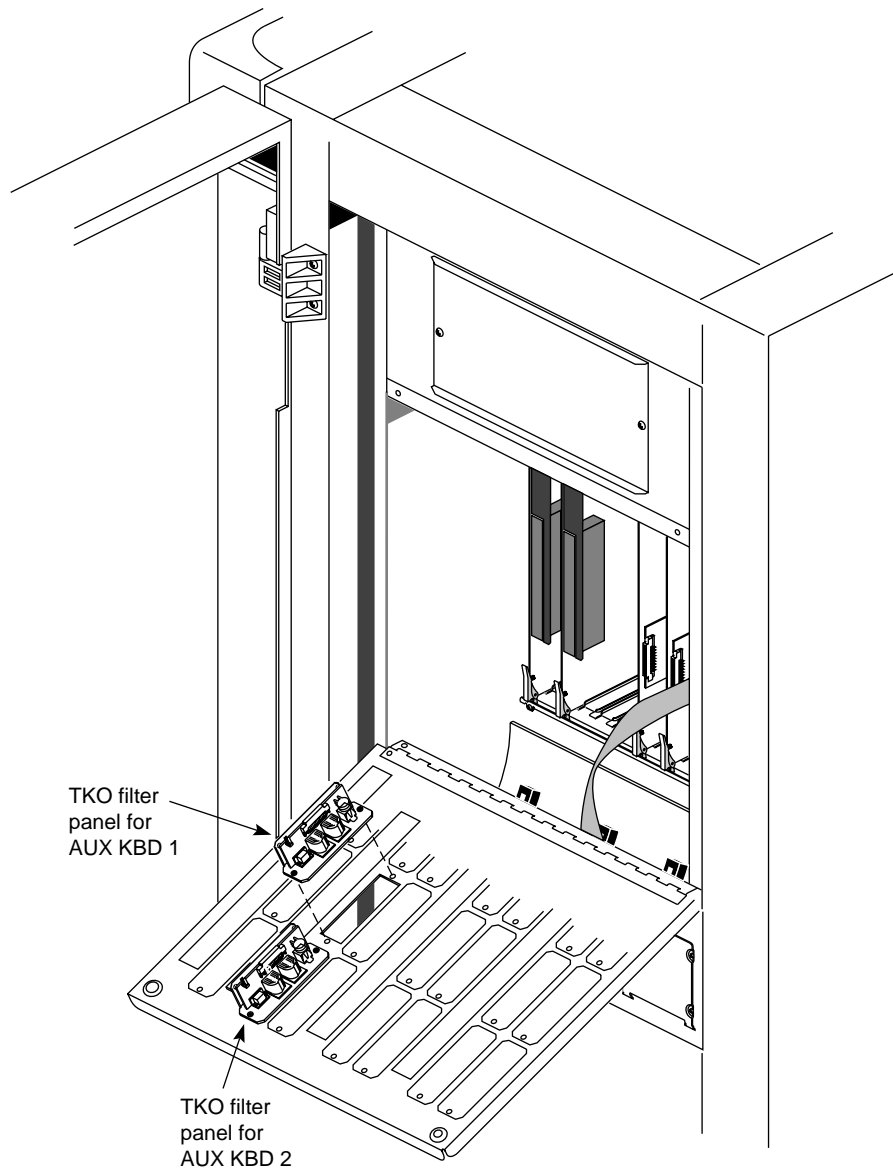

Figure 2-5 Installing TKO Filter Panels

2.4 Attaching Ribbon Cables

Ribbon cables connect the daughtercards on the “second” and “third” IO4 boards to the TKO filter panels. (Of course, the primary IO4 board’s ribbon cable is already attached to the I/O panel below cardcage 2.) Follow these steps:

1. Attach one end of a ribbon cable to the connector on the daughtercard on the “second” IO4. The connectors on the ribbon cables are keyed. Attach the other end to the bottom or leftmost filter panel on the cardcage 2 I/O door, as viewed with the I/O door closed. This should be the filter panel labeled **AUX KBD 1**.
2. Attach one end of the second ribbon cable to the connector on the daughtercard on the “third” IO4. Attach the other end to the top or rightmost filter panel on the cardcage 2 I/O door (as viewed with the I/O door closed). This should be the filter panel labeled **AUX KBD 2**. Figure 2-6 shows the ribbon cables installed.

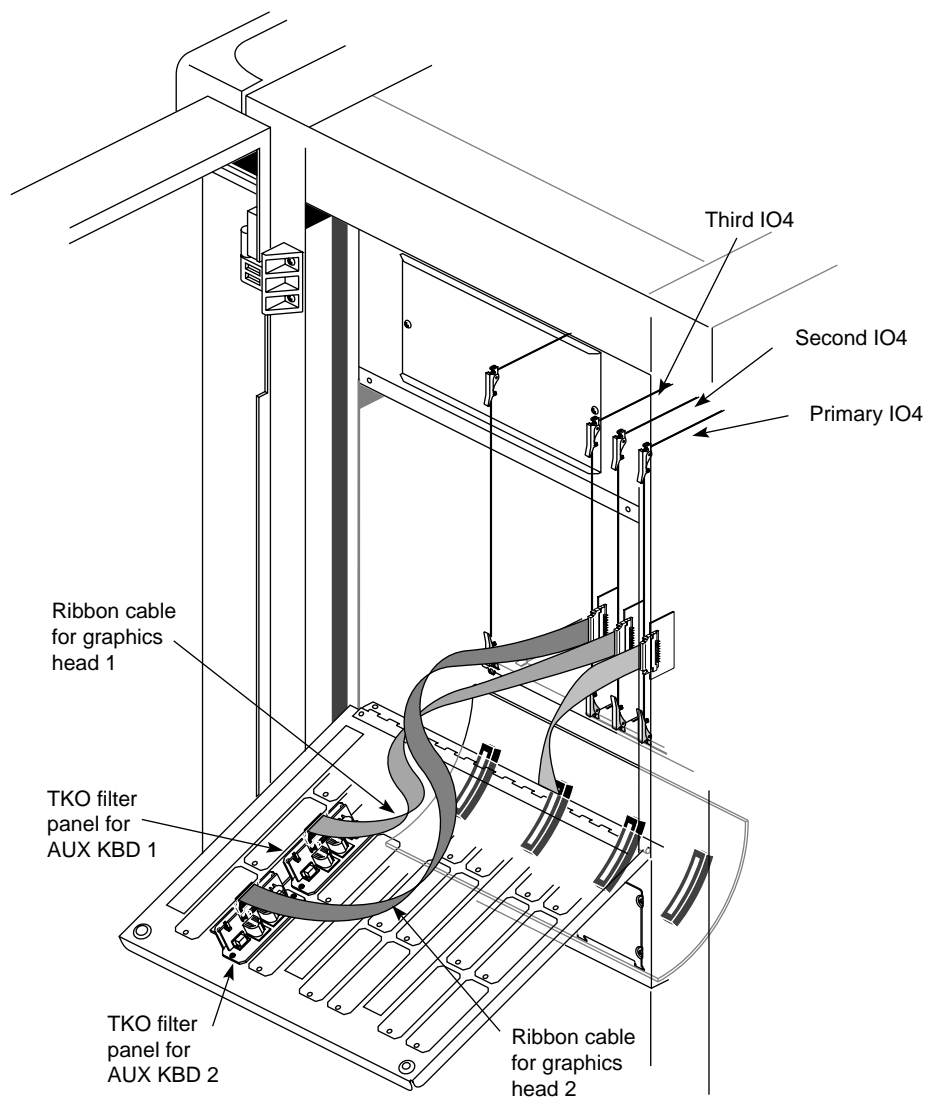

Figure 2-6 Installing Ribbon Cables

2.5 Cabling the Keyboards and Monitors

Determine where the customer wants the additional monitors, keyboards, and mice, and place them there. Make sure there is agreement on the numbering of the monitor and keyboard combinations.

The standard (suggested) configuration is summarized in Table 2-2.

Table 2-2 Cabling Keyboards for TKO

Keyboard	Cabling
0 (Original)	Leave cabled as is to the original I/O panel, which is internally cabled to graphics head 0
1	Keyboard connector on the bottom or leftmost filter panel (AUX KBD 1) on the cardcage 2 I/O door, which is internally cabled to second IO4 and graphics head 1
2	Keyboard connector on the top or rightmost filter panel (AUX KBD 2) on the cardcage 2 I/O door, which is internally cabled to optional third IO4 and graphics head 2

Attach keyboard and monitor extension cables to the appropriate connectors on the I/O panels. Figure 2-7 diagrams attachment of the external keyboard and monitor cables.

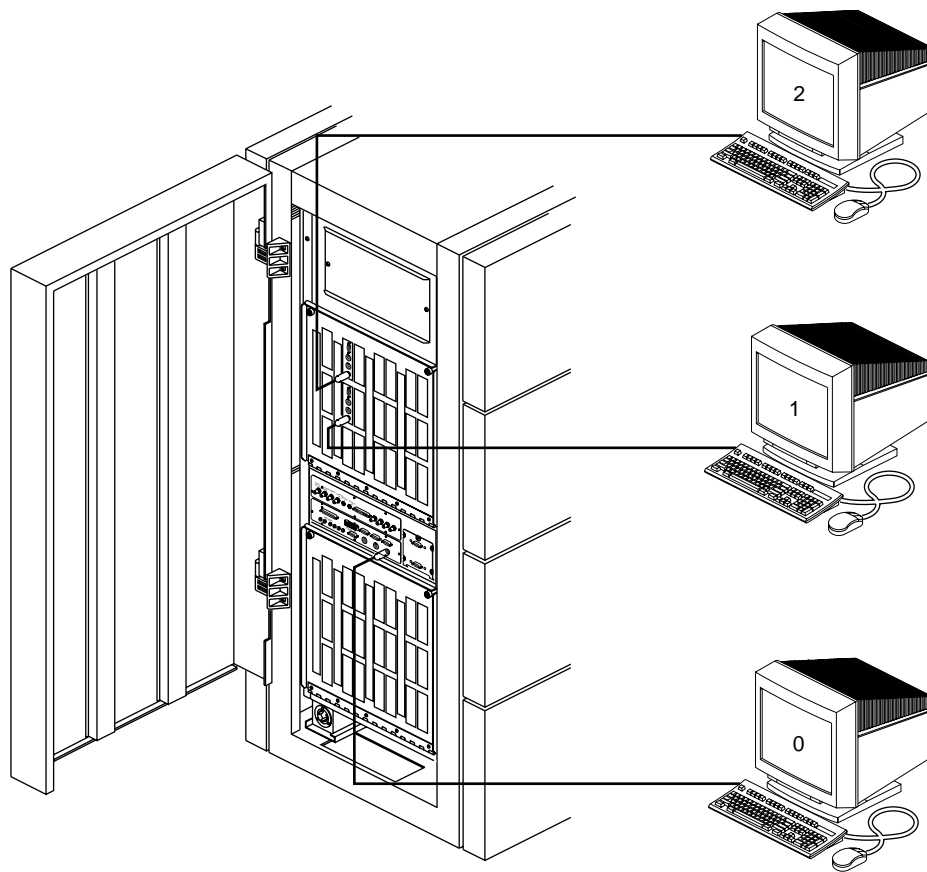

Figure 2-7 Attaching TKO External Cables

2.6 Cabling Serial Ports

The main I/O panel on the Onyx rackmount provides two types of ports for RS-232 peripherals—a 9-pin sub-D and a round 8-pin DIN connector. On the main I/O panel, these connectors are arranged one above the other; a bracket on the silkscreen links the two types of ports to indicate that only one should be used and not both.

However, the TKO filter panels have only the round 8-pin DIN connectors for powered peripherals (TTY 46 and TTY 47 on the TKO filter panel with **AUX KBD 1**, and TTY 50 and TTY 51 on the TKO filter panel with **AUX KBD 2**). The corresponding 9-pin sub-D connectors are on the standard I/O panels for the second and third IO4s. Although for the second and third IO4s the two types of serial ports are on separate panels, still only one or the other type of port can be used at one time, not both, just as in the case of the main I/O panel.

Table 2-3 summarizes serial port correspondences.

Table 2-3 Serial Port Correspondences

Round 8-pin DIN Connector Label (Powered Peripheral Port)	Corresponds to:	Sub-D Connector Label (Unpowered Peripheral Port)
AUX KBD 1 panel: TTY_46		I/O panel for “second” IO4: TTY_46
AUX KBD 1 panel: TTY_47		I/O panel for “second” IO4: TTY_47
AUX KBD 2 panel: TTY_50		I/O panel for “third” IO4: TTY_50
AUX KBD 2 panel: TTY_51		I/O panel for “third” IO4: TTY_51

Note: Use the serial port listed in one column or the other, not both. For example, if you use the round 8-pin DIN connector for TTY 46 on the **AUX KBD 1** panel, do not also use the 9-pin sub-D for TTY 46 on the I/O panel connected to the “second” IO4.

Figure 2-8 shows serial port usage.

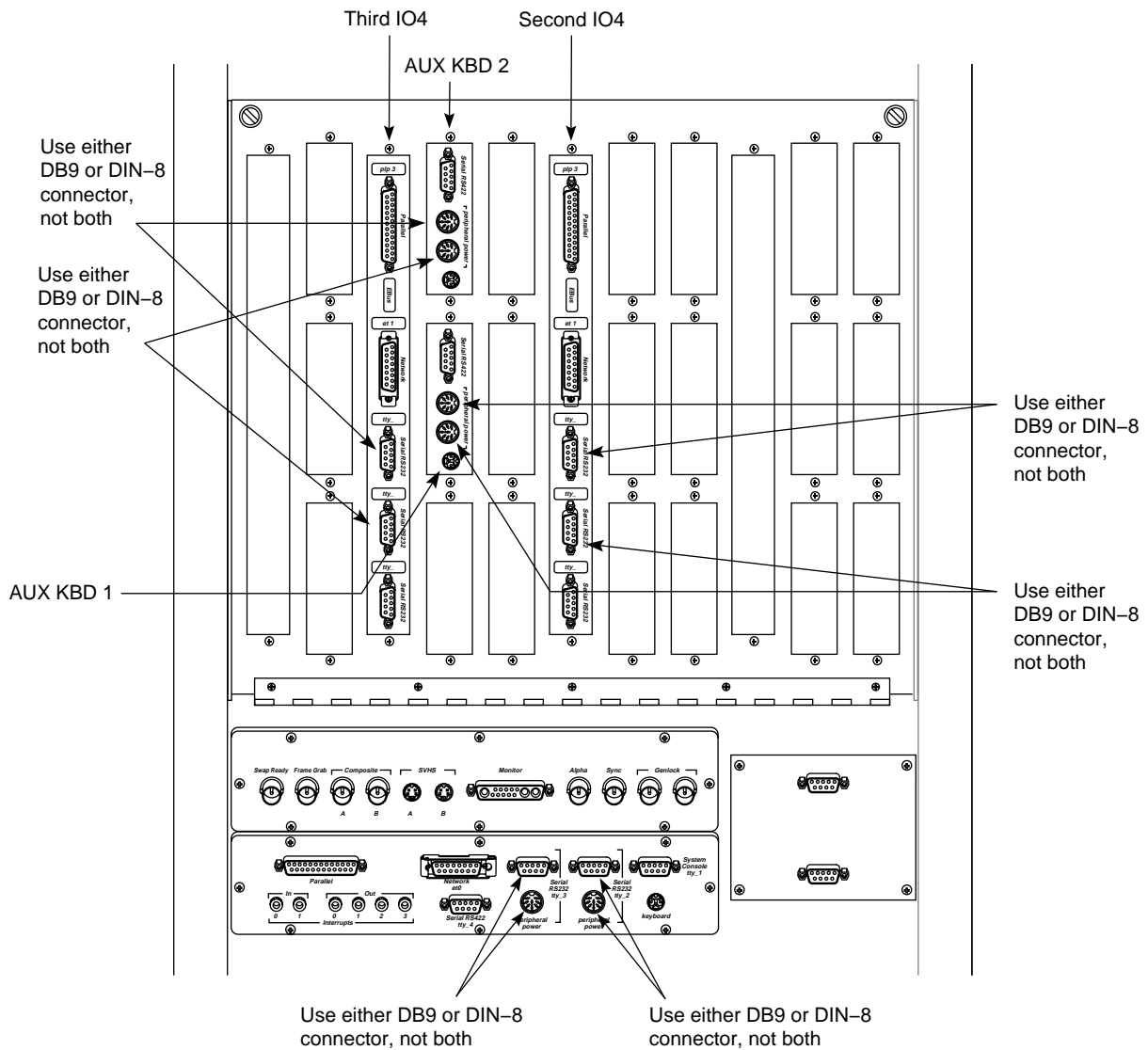

Figure 2-8 Serial Port Usage

2.7 Creating Input Devices

Some systems may not have the input device files preconfigured. To check for this, type:

```
ls -l /dev/input1
```

You should see both a keyboard and a mouse device listed. If instead you see something like:

```
Cannot access /dev/input1: No such file or directory
```

then you will need to create the device files. To do this, become root and type:

```
cd /dev
./MAKEDEV ttys
```

This will create */dev/input1* and */dev/input2*.

2.8 Setting up IRIX for the Triple-Keyboard Option

The base version of IRIX 6.2 supports the triple keyboard option. There is thus no OS upgrade required as part of the TKO for IR installation.

IRIX 6.2 includes an example version of the xdm *Xservers* configuration file. This example file is located in the */var/X11/xdm* directory, and is called *Xservers.3key*. The standard three-keyboard operation described in this chapter is mapped as follows:

- graphics pipe 0 and main keyboard operating as X server :0
- graphics pipe 1 and auxilliary keyboard 1 operating as X server :1
- graphics pipe 2 and auxilliary keyboard 2 operating as X server :2

To set up IRIX for this operation, follow these steps:

1. Move */var/X11/xdm/Xservers* to */var/X11/xdm/Xservers.1key*:

```
mv /var/X11/xdm/Xservers /var/X11/xdm/Xservers.1key
```

2. Copy */var/X11/xdm/Xservers.3key* to */var/X11/xdm/Xservers*:

```
cp /var/X11/xdm/Xservers.3key /var/X11/xdm/Xservers
```

3. To enable the new xdm configuration file, rlogin, or log in through a serial port, and type as root:

```
/usr/gfx/stopgfx
/etc/killall xdm
/usr/gfx/startgfx
```

To set up the software for a different configuration, edit */var/X11/xdm/Xservers*, as explained in Section 2.9.

2.9 Configuring the Triple-Keyboard Option

IRIX includes both a single-keyboard default file, */var/X11/xdm/Xservers*, and a triple-keyboard example file, */var/X11/xdm/Xservers.3key*. The *Xservers.3key* file shows a three-keyboard graphics-pipe/keyboard/X server configuration.

You can copy the *Xservers.3key* file to */var/X11/xdm/Xservers* (as described in Section 2.8), or edit the *Xservers* file to include the configuration you want.

Note: The `/var/X11/xdm/Xservers` file contains the only copy of the standard single-keyboard mapping. It is therefore recommended that you copy it to `Xservers.1key` before overwriting it with the contents of the `Xservers.3key` file.

The `Xservers` and `Xservers.3key` files differ in the line(s) specifying X server configuration. The standard `/var/X11/xdm/Xservers` file has one line defining the X server configuration:

```
:0 secure /usr/bin/X11/X -bs [...]
```

The `/var/X11/xdm/Xservers.3key` file has three lines defining the X server configuration:

```
:0 secure /usr/bin/X11/X :0 -boards 0 -devdir /dev/input -bs [...]  
:1 secure /usr/bin/X11/X :1 -boards 1 -devdir /dev/input1 -bs [...]  
:2 secure /usr/bin/X11/X :2 -boards 2 -devdir /dev/input2 -bs [...]
```

These lines start three X servers, one for each keyboard/graphics-pipe pair in the system. The `-boards n` parameter specifies the graphics pipe(s) to be used by the respective X server.

The configuration in `Xservers.3key` matches the standard hardware configuration described in Section 2.8. The main keyboard and graphics pipe 0 are associated with the X server at `:0`. Auxiliary keyboard 1 and graphics pipe 1 are associated with the X server at `:1`. Auxiliary keyboard 2 and graphics pipe 2 are associated with the X server at `:2`.

If the customer wants a different configuration, edit the `/var/X11/Xdm/Xservers` file. For example, the following lines associate the main keyboard and graphics pipe 0 with the X server at `:0`, and associate auxiliary keyboard 1 and graphics pipes 1 and 2 with the X server at `:1`.

```
:0 secure /usr/bin/X11/X :0 -boards 0 -devdir /dev/input -bs [...]  
:1 secure /usr/bin/X11/X :1 -boards 1,2 -devdir /dev/input1 -bs [...]
```

Note: For more information on `-boards` and `-devdir`, see the `Xsgi(1)` IRIX man page. For more information on graphics pipe numbers, run `/usr/gfx/gfxinfo`.

2.10 Testing the New Installation

The `hinv` utility does not report the presence of triple keyboard option. To test the newly installed TKO, check the operation of each keyboard/monitor pair.

Comments About This SSE Document

Please take a few minutes to think about what you found helpful or bothersome in this SSE document. We will use your comments to enhance future revisions of this document.

While we'd like to hear any feedback you may have, some specific ideas are:

- Errors in the technical content
- Errors in the illustrations
- Omission of material you needed
- Relevance of the material to the job you had to do
- Any part of the document you found particularly useful
- Insights from your experience in the field

Where to send your comments:

- Send email to techpubs@sgi.com
- Fax marked-up drawings to Technical Publications at (415) 965-0964

Along with your comments, please remember to include the title and part number of the document on which you are commenting.

Thank you.

