

Audio/Serial Option Board Installation Instructions

Document Number 108-0134-001

Contributors

Written by Pablo Rozal and Kam Kashani

Illustrated by Dan Young

Edited by Christina Cary

Production by Julia Lin

Engineering contributions by Bharat Patel, Reuel Nash, Tom Wong, Jeff Milo, Joe Wang, Dale Witt, Stanley Lee, Bill Warner, Judy Bergwerk

© Copyright 1995, Silicon Graphics, Inc.— All Rights Reserved

This document contains proprietary and confidential information of Silicon Graphics, Inc. The contents of this document may not be disclosed to third parties, copied, or duplicated in any form, in whole or in part, without the prior written permission of Silicon Graphics, Inc.

Restricted Rights Legend

Use, duplication, or disclosure of the technical data contained in this document by the Government is subject to restrictions as set forth in subdivision (c) (1) (ii) of the Rights in Technical Data and Computer Software clause at DFARS 52.227-7013 and/or in similar or successor clauses in the FAR, or in the DOD or NASA FAR Supplement. Unpublished rights reserved under the Copyright Laws of the United States. Contractor/manufacturer is Silicon Graphics, Inc., 2011 N. Shoreline Blvd., Mountain View, CA 94039-7311.

FCC Warning

This equipment has been tested and found compliant with the limits for a Class A digital device, pursuant to Part 15 of the FCC rules. These limits are designed to provide reasonable protection against harmful interference when the equipment is operated in a commercial environment. This equipment generates, uses, and can radiate radio frequency energy and, if not installed and used in accordance with the instruction manual, may cause harmful interference to radio communications. Operation of this equipment in a residential area is likely to cause harmful interference in which case the user will be required to correct the interference at his own expense.

Attention

This product requires the use of external shielded cables in order to maintain compliance pursuant to Part 15 of the FCC Rules.

**Audio/Serial Option Board Installation Instructions
Document Number 108-0134-001****Silicon Graphics, Inc.
Mountain View, California**

Silicon Graphics and IRIS are registered trademarks and IRIX, POWER Center, CHALLENGE, CHALLENGE L, CHALLENGE XL, Onyx, POWER CHALLENGE, POWER Onyx, Reality Station, and Indigo2 are trademarks of Silicon Graphics, Inc. Motorola is a registered trademark and MC68302 and VMEbus are trademarks of Motorola Corporation.

Contents

Introductionix

Structure of This Documentix

Related Documentix

Typographical Conventionsx

1. ASO Board Overview1-1

1.1 Serial Features1-1

1.2 Audio Features1-1

1.3 ASO Functional Description1-2

1.3.1 Serial Section1-2

1.3.2 Audio Section1-2

2. Installing the Audio/Serial Option Board2-1

2.1 Safety Information2-1

2.2 Software Dependencies2-2

2.3 ASO Kit Contents2-2

2.4 Installing the ASO Board2-2

2.4.1 Selecting a Mezzanine Slot2-4

2.4.2 Installing the Mezzanine Board2-5

2.4.3 Installing the I/O Connector Bulkheads2-6

2.4.4 Removing Boards in Slots 1 in 2 From a Deskside System2-10

2.4.5 Connecting the Internal ASO Cables2-11

2.5 Installing the ASO Software2-15

2.6 Important S/W Installation Information for IP21 Systems2-16

2.7 Verifying Installation2-16

2.8 Testing the Ports2-17

2.8.1 Audio Tests2-17

2.8.2 Serial Tests2-17

- 3. Configuring the Ports3-1**
 - 3.1 Using Serial Devices3-1
 - 3.1.1 Serial Modes and Baud Rates3-3
 - 3.1.2 Setting Up the Serial Ports3-3
 - 3.2 Audio Devices3-4

- A. Serial and Audio Serial Connector Pinout InformationA-1**
 - A.1 Serial ConnectorsA-1

Figures

Figure 1-1	ASO Block Diagram1-3
Figure 1-2	ASO Component Layout Diagram1-4
Figure 2-1	Pictorial Overview of Installation for ASO Hardware2-3
Figure 2-2	Upper and Lower Mezzanine Slots on IO4 Boards2-4
Figure 2-3	IO4 Board With ASO Mezzanine Board2-5
Figure 2-4	I/O Plate Removal Locations for Onyx and POWER Onyx Deskside, Reality Station, and All Rackmount Systems2-6
Figure 2-5	I/O Plate Removal Locations for Challenge or POWER Challenge L Systems2-7
Figure 2-6	ASO Connector Bulkhead Location (Onyx Deskside Shown)2-8
Figure 2-7	AIO Connector Bulkhead Installation Caution2-9
Figure 2-8	AIO Connector Bulkhead Removal Reminder2-10
Figure 2-9	ASO Cable Assemblies2-11
Figure 2-10	Connecting the ASO Cables2-13
Figure 2-11	A Typical Cabling Scenario2-14
Figure 3-1	SIO Ports for Audio/Serial Option3-2
Figure 3-2	Possible Audio Connector Problem With I/O Door3-5
Figure A-1	ASO Serial Connector Pin LocationsA-2

Tables

Table 2-1	ASO Kit Contents2-2
Table 2-2	Available IO4 Slots in Each System2-4
Table 3-1	How the Serial Ports Correspond to IRIX Device Files3-1
Table 3-2	ASO Serial Port Device Entries and Baud Rates3-3
Table 3-3	Audio Connections3-4
Table A-1	ASO Serial ConnectorsA-1
Table A-2	Audio Port ConnectorsA-2

Introduction

This document describes the procedures for installing an Audio/Serial Option (ASO) board into an existing Silicon Graphics® CHALLENGE™, POWER CHALLENGE, Onyx™, POWER Onyx, or Reality Station™ system. The ASO is a short mezzanine board that mounts directly on the IO4.

The ASO board provides six serial ports and five audio ports. Each serial port is capable of running at up to 115.2 Kbaud/sec in full duplex mode.

Note: The ASO board is also known internally as the Serial Audio Mezzanine (SAMz) board.

This manual is written for Silicon Graphics system support engineers (SSEs) and third-party field support groups responsible for product installation and testing.

Structure of This Document

This manual is organized as follows:

- Chapter 1 “ASO Board Overview” provides a summary of the ASO features and principles of operation.
- Chapter 2 “Installing the ASO Board” discusses how to install the upgrade.
- Chapter 3 “Configuring the Ports” describes how to configure and use the serial (RS-232 and RS-422) and audio ports.
- Appendix A “Serial and Audio Connector Pinout Information” provides pinout and connector information for the audio and serial ports.

Related Document

The *Audio/Serial Option User's Guide* (p/n 007-2645-xxx) describes how to set up, configure, and operate the audio and serial ports available on the ASO board.

Typographical Conventions

These type conventions and symbols are used throughout this manual:

<i>Italics</i>	Filenames, variables, IRIX command arguments, command flags, titles of publications, icon names.
Screen type	Code examples, file excerpts, and screen displays (including error messages).
Bold Screen type	User input
()	(Parentheses) Following IRIX commands, they surround the reference page (man page) section where the command is described. For example, <i>grep</i> (1).
[]	(Brackets) Surrounding optional syntax statement arguments.
#	IRIX shell prompt for the superuser (<i>root</i>).

Chapter 1

ASO Board Overview

This chapter highlights the features of the Audio/Serial Option (ASO) board upgrade and provides a block diagram description and a board-layout drawing.

1.1 Serial Features

The ASO supports the following serial features:

- six asynchronous serial ports with 9-pin D-shell connectors that are software-selectable between RS-232 and RS-422
- no loss of serial characters at 115.2 Kbaud/sec
- at least 115.2 per channel while running in full duplex mode
- baud rates up to 38.4 through the standard *tty* interface or up to 115.2 through a user-supplied program

Caution: The baud rate can be set to a higher speed (beyond 115.2 Kbaud/sec), however, these rates are not supported by Silicon Graphics. Operating beyond 115.2 can result in possible loss of serial characters and overall degraded performance.

1.2 Audio Features

The ASO provides the following audio input and outputs.

- headphone output (stereo)
- microphone input (mono or stereo)
- line-level input (stereo)
- line-level output (stereo)
- digital input/output

See Chapter 3, “Configuring the Ports,” for a list and description of the audio ports.

Note: The ASO does *not* provide audio time stamping.

1.3 ASO Functional Description

The ASO board provides audio I/O and asynchronous serial I/O and handles real-time streams of data. The ASO also channels 5 volts of power for the audio components. The 5 volts is supplied through the IO4 board.

Figure 1-1 provides a block diagram of the ASO board. A DANG (Dual-purpose Adapter for Network and Graphics) chip translates between the IBus and GIO bus. The 64-bit Ibus is the main internal bus on the IO4 board. The GIO (graphics input/output) bus is the major bus on the ASO board. Data transfers to and from the board are done through DMAs, either through the audio or serial section. An HPC3 (High-Performance serial Controller) provides buffering and additional DMA control.

1.3.1 Serial Section

Two Motorola[®] MC68302[™] integrated multiprotocol processors provide three serial controllers each. One serves as the slave, the other as the master. Both master and slave contain independent DMA engines for moving incoming and outgoing serial data.

The master 68302 processor executes code from an external 128 KB SRAM. The master 68302 also performs the necessary housekeeping functions on data sent to and received from the host.

Two word-wide mailbox registers interface the 68K bus to the HD0 and HD1 ports of the HPC3 chip. The FIFO of the HD ports allow enough serial data to be exchanged with host memory during serial data transmission to overcome any system latency.

1.3.2 Audio Section

The audio section of the ASO board uses the same basic design as the audio circuitry in the Indigo2[™] system. The major component in the audio section is a HAL2 ASIC. The HAL2 provides the data path and control logic to interface the HPC3 Pbus and the audio devices on the module.

The audio FIFOs (four 256 x 16) respond to DMA channel requests from the HAL2 and transmit or receive DMA information as directed by the HAL2. The HAL2 also allows a PIO to interleave whenever a DMA channel request has been completed. The HPC3 side of the audio FIFOs makes sure that the HAL2 side never overruns the audio FIFOs.

Figure 1-1 ASO Block Diagram

Figure 1-2 ASO Component Layout Diagram

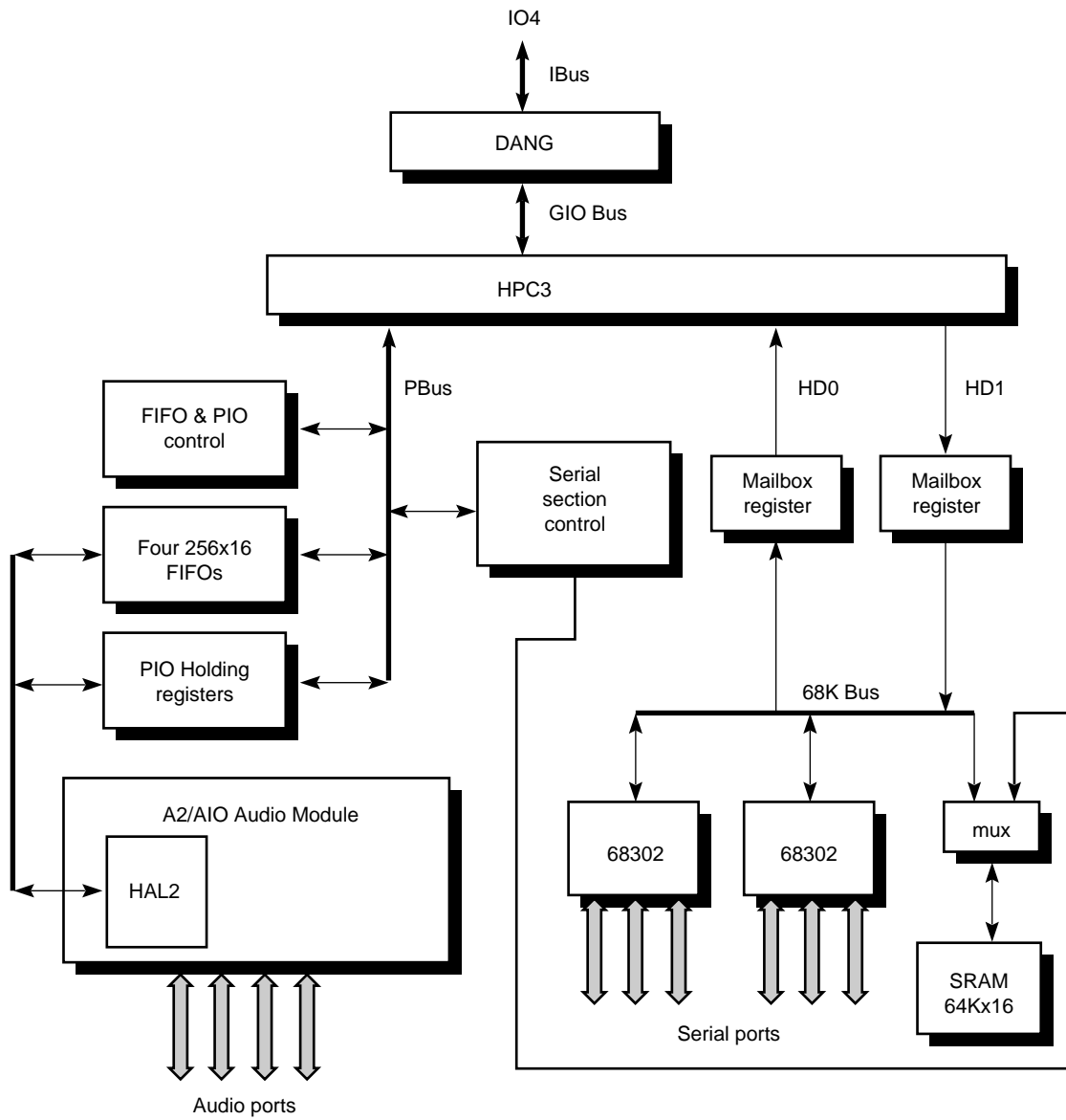

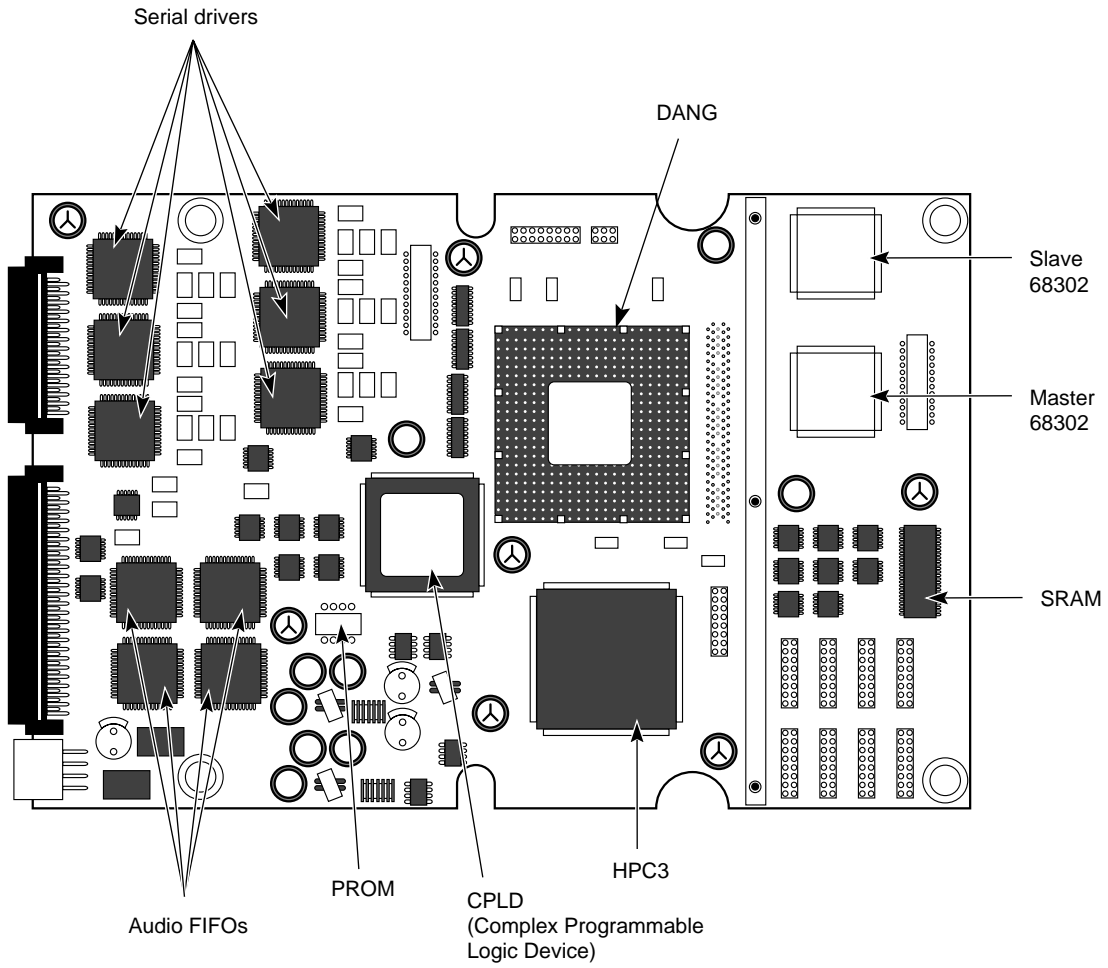

Installing the Audio/Serial Option Board

This chapter describes how to install the Audio/Serial Option (ASO) board into a Challenge, Onyx, POWER Challenge, POWER Onyx, or Reality Station system. The ASO is a short mezzanine board that installs on any available IO4 board. A system can support a maximum of one ASO board at first-product release.

Note: The addition of an ASO board does not affect the operation and performance of existing serial ports on the system.

2.1 Safety Information

Be sure to read the following information before you begin installation.



Warning: Installation of these upgrades requires specific training and technical knowledge. These instructions are provided for use by Silicon Graphics system support engineers (SSEs) or other Silicon Graphics-trained personnel only. This equipment utilizes electrical power internally that is hazardous if the equipment is improperly disassembled.

Caution: This equipment is extremely sensitive and susceptible to damage caused by electrostatic discharge (ESD). ESD is an electrical discharge caused by the build-up of electrostatic potential on clothing and other materials.

Follow these ESD-preventive measures:

- Connect a ground strap to your wrist when installing and removing peripherals.
- Be sure that you and all of the electrical equipment that you handle during this installation remain at a ground potential of zero to avoid damage from ESD.
- Remove a board from its antistatic bag only when you are properly grounded with a ground strap, and only when you are working on the board or installing it.
- Do not use an ohmmeter on a board.

2.2 Software Dependencies

The system must be running one of two operating system versions.

- 5.3 or later for IP19-based Challenge, Onyx, and Reality Station systems
- 6.0.1 or later for IP21-based POWER Challenge and POWER Onyx systems
- the system must also have the ASO software driver on CD-ROM

2.3 ASO Kit Contents

Verify that the ASO package is complete. It should contain the items listed in Table 2-1 (see also Figure 2-1).

Description	Part Number
Audio Serial Option board	030-0753-001
SIO connector bulkhead	013-1203-001
AIO connector bulkhead	013-1204-001
SIO cable assembly	018-0495-001
AIO power harness assembly	015-0239-001
AIO cable assembly	018-0496-001

Table 2-1 ASO Kit Contents

Caution: If anything is missing, do not proceed with the installation. Contact the customer or the customer's salesperson.

2.4 Installing the ASO Board

This section describes the steps for installing the ASO into a Challenge, Onyx, POWER Challenge, and POWER Onyx deskside or rackmount system, or the Reality Station deskside system. Figure 2-1 provides an overview of the hardware installation.

Caution: This equipment is extremely sensitive and susceptible to damage by electrostatic discharge (ESD) a spark caused by the buildup of electrical static. You must use proper ESD preventive measures as explained in Section 2.1, "Safety Information."

1. Verify that the IRIX operating system is the correct version for this upgrade, using the command below. Do not proceed until the correct version of IRIX is installed. See Section 2.2, "Software Dependencies."

```
% versions eoel
I eoel date Execution Only Environment 1, version
```

Figure 2-1 Pictorial Overview of Installation for ASO Hardware

2. Verify that the customer has backed up the filesystem.

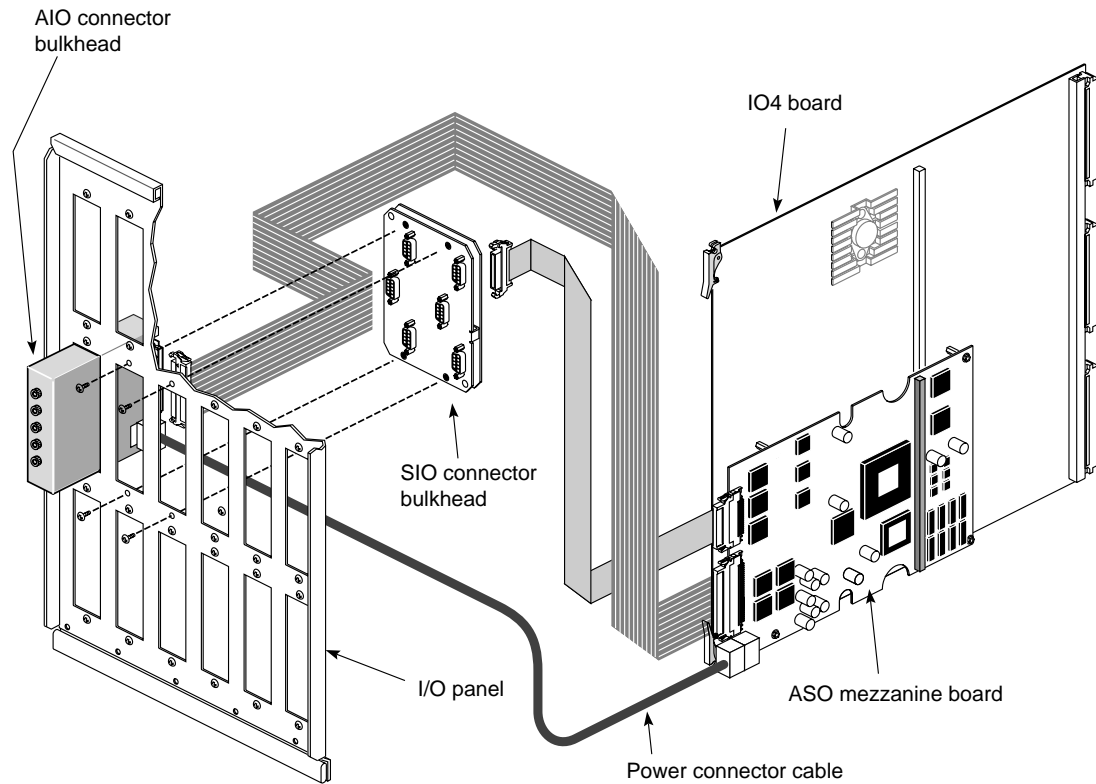

3. Invoke the *shutdown* command and wait for a power off indication.
4. Shut down the system by turning the key on the System Controller panel (located at the front) to **OFF**. Wait a minute for the system to shut down, then switch the circuit breaker to **OFF**.



Warning: Failure to turn off the circuit breaker may result in electrical shock. Failure to wait for the system to shut down may cause irreparable damage to system components or data.

5. Open the front door (on a desktside system) or rear door (on a rackmount system) and pull down the I/O panel on the chassis to expose the IO4 boards.

2.4.1 Selecting a Mezzanine Slot

Locate the IO4 boards that are currently installed. Table 2-2 shows the possible locations of the IO4 board in each system. In addition, follow these guidelines for selecting a mezzanine slot.

- If the system has only one IO4 board, this is the location for the mezzanine board. The ASO, which is a short mezzanine board may be installed in either the upper or lower position on the IO4 board, as illustrated in Figure 2-2.
- If there are no unoccupied mezzanine slots, you must install another IO4 board. Contact the sales representative to order one. The installation cannot be continued until a mezzanine slot is available.
- Remember: only one ASO board is supported in the first product release.

System	Slots That Can Be Used
Challenge or POWER Challenge L (Deskside) Server	Upper or lower mezzanine slot on an IO4 board in slot 5, 4, or 3
Onyx, POWER Onyx, or Reality Station (Deskside) Workstation	Upper or lower mezzanine slot on IO4 board in slot 3
Challenge or POWER Challenge XL (Rackmount) Server	Upper or lower mezzanine slot on an IO4 board in slot 15, 13, 11, 9, 7, or 5
Onyx or POWER Onyx (Rackmount) Workstation	Upper or lower mezzanine slot on an IO4 board in slot 11, 9, 7, or 5

Table 2-2 Available IO4 Slots in Each System

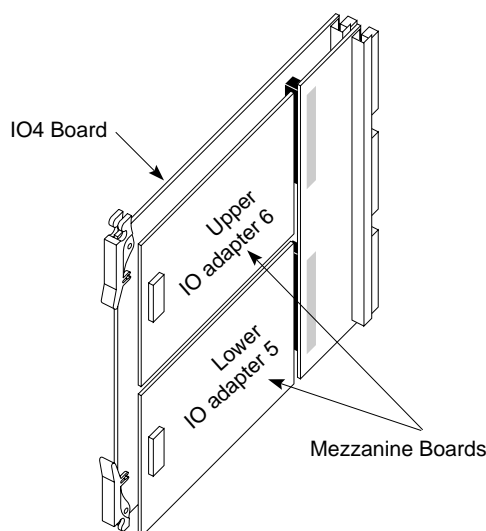

Figure 2-2 Upper and Lower Mezzanine Slots on IO4 Boards

2.4.2 Installing the Mezzanine Board

Follow the steps below to install the ASO board.

1. Remove the IO4 board that you have selected from the chassis.
2. Lay the board on a flat antistatic surface so that the component side faces up and the SCSI connectors face toward you, as illustrated in Figure 2-3.

3. Locate the selected mezzanine slot (upper or lower) and remove the four screws from the standoffs, as illustrated in Figure 2-3.

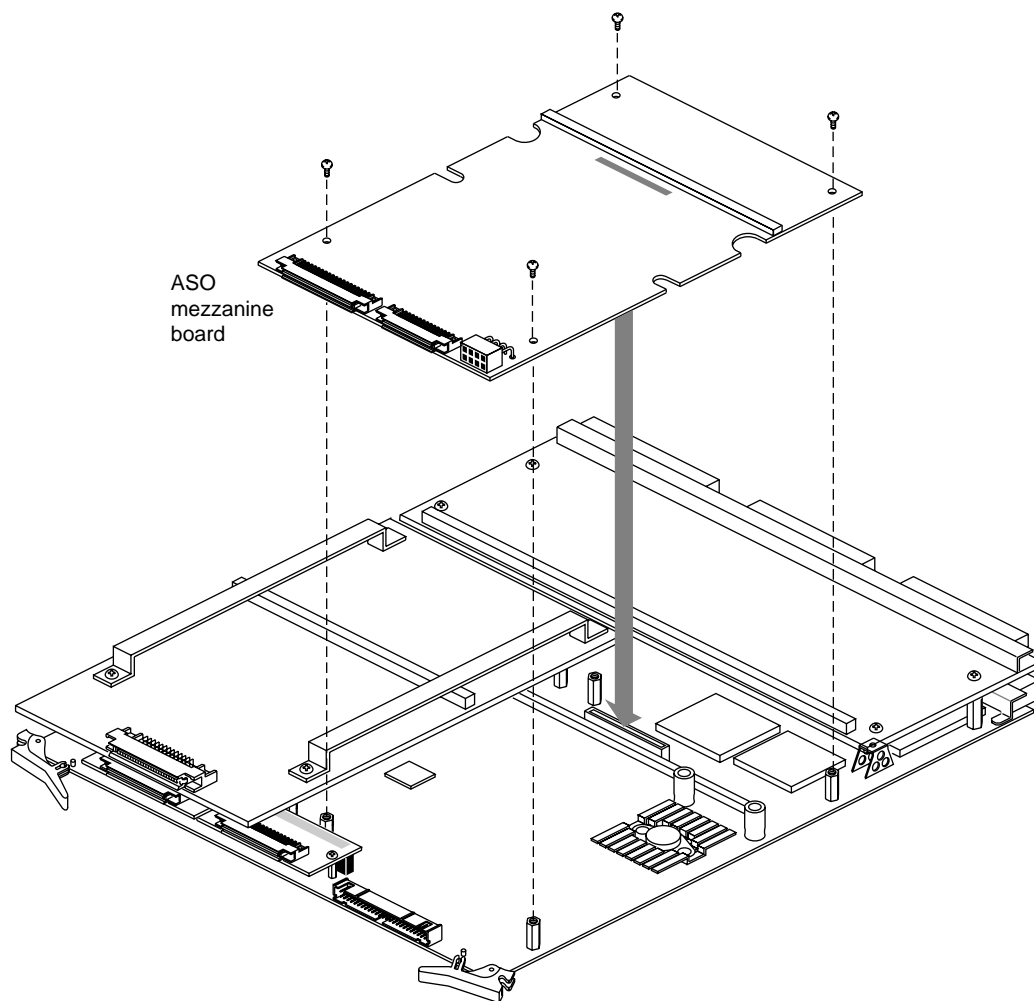

Figure 2-3 IO4 Board With ASO Mezzanine Board

4. Position the ASO board onto the mezzanine board receptacle on the IO4 board and make sure the standoffs match the board's holes. Figure 2-3 illustrates the correct positioning for the lower mezzanine slot.
5. Replace the standoff screws. Use the screws removed previously or the shipped screws. The standoffs have a “float” feature, so the ASO can move slightly when the screws are fully tightened.
6. Reinstall the IO4 board into the chassis. Push the board firmly into the backplane. If the board has a VCAM board, the VCAM board must also connect to the backplane.

2.4.3 Installing the I/O Connector Bulkheads

The ASO has two I/O connector bulkheads that occupy three I/O panels (see Figure 2-1 and Figure 2-6):

- the AIO (audio) connectors use one I/O panel slot
- the SIO (serial) connectors use two I/O panel slots

Caution: The AIO connector bulkhead must be installed in the leftmost slot in the middle row on the I/O panel so that the I/O panel can properly close and to allow sufficient room for excess ASO cabling (see Figure 2-6).

Follow these instructions to install the I/O connector bulkheads.

1. If you have an Onyx, POWER Onyx, or Reality Station deskside, or any of the rackmount systems, remove the three left I/O plates from the middle row of the I/O panel (see Figure 2-4). If there are existing connector panels in these slots, move these connectors to another location on the I/O panel.

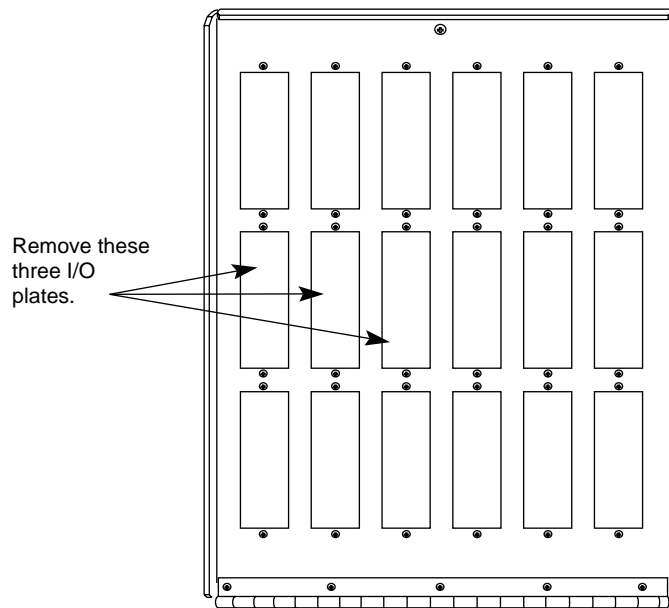

Figure 2-4 I/O Plate Removal Locations for Onyx and POWER Onyx Deskside, Reality Station, and All Rackmount Systems

If you have a Challenge or POWER Challenge L (deskside) system, remove the two left plates on the upper row and the leftmost I/O plate on the middle row (see Figure 2-5). If there are existing connector panels in these slots, move these connectors to another location on the I/O door.

Figure 2-5 I/O Plate Removal Locations for Challenge or POWER Challenge L Systems⁹

2. Install the AIO connector bulkhead into the leftmost I/O slot position in the middle row of the I/O panel (see Figure 2-6).

Caution: You *must* install the AIO (audio) connector bulkhead as shown in Figure 2-6. This positioning normally provides the most room for cabling and also does not interfere with existing IO4 SCSI cables. If you place the audio bulkhead in any other slot position, you could damage existing cables and board connectors when the I/O panel is closed.

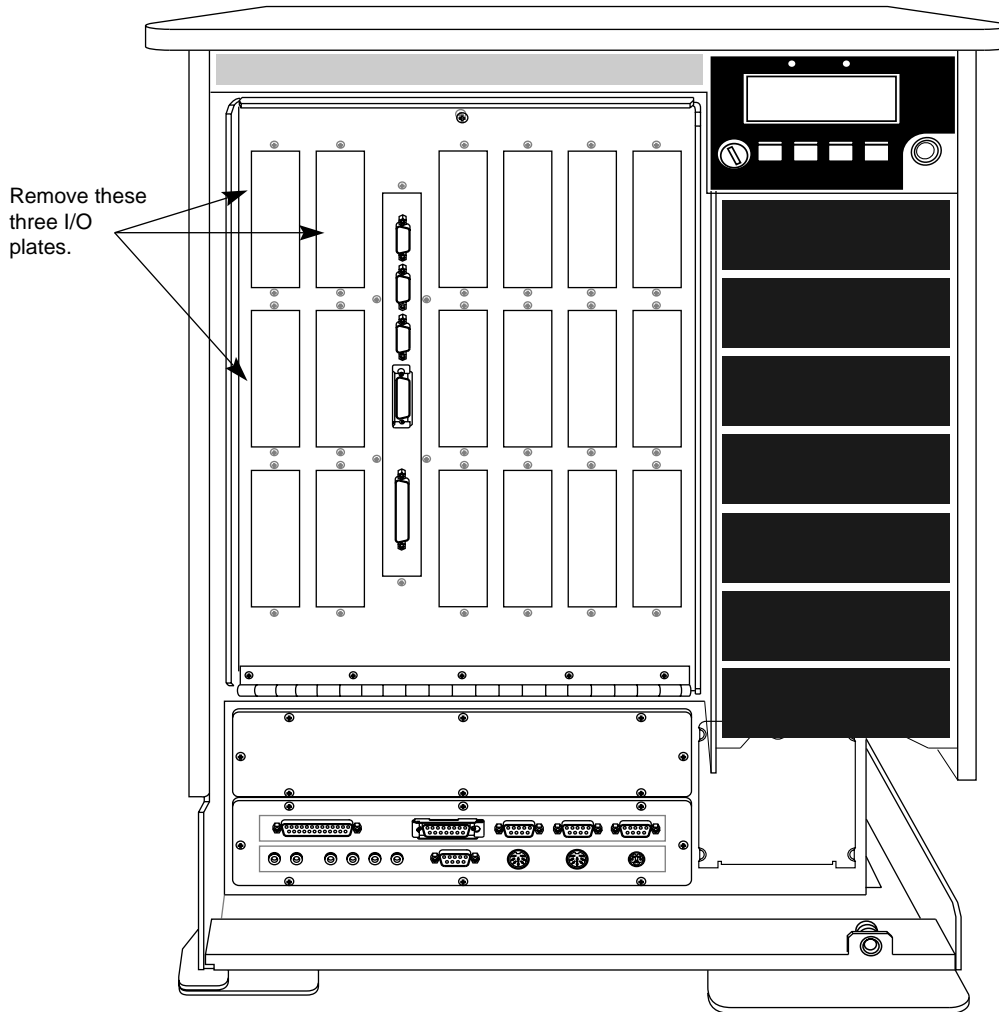

Figure 2-6 ASO Connector Bulkhead Location (Onyx Deskside Shown)

In addition, *do not* install the audio bulkhead into the upper left slot on the I/O panel. Assuming that an upper card guide retainer bracket is in place, this causes the bulkhead to hit against a screw on the upper card guide bracket when you try to close the I/O panel (see Figure 2-7). This prevents the I/O panel from properly closing.

Figure 2-7 AIO Connector Bulkhead Installation Caution

Caution: Do not place the AIO connector bulkhead in the upper left slot position.

3. If you have an Onyx or POWER Onyx deskside system, Reality Station, or one of rackmount systems, install the SIO connector bulkhead into the second and third I/O slots of the middle row of the I/O panel. See Figure 2-6.

If you have a Challenge or POWER Challenge L system, install the SIO connector bulkhead into the upper left slots on the first row of the I/O panel. See Figure 2-6.

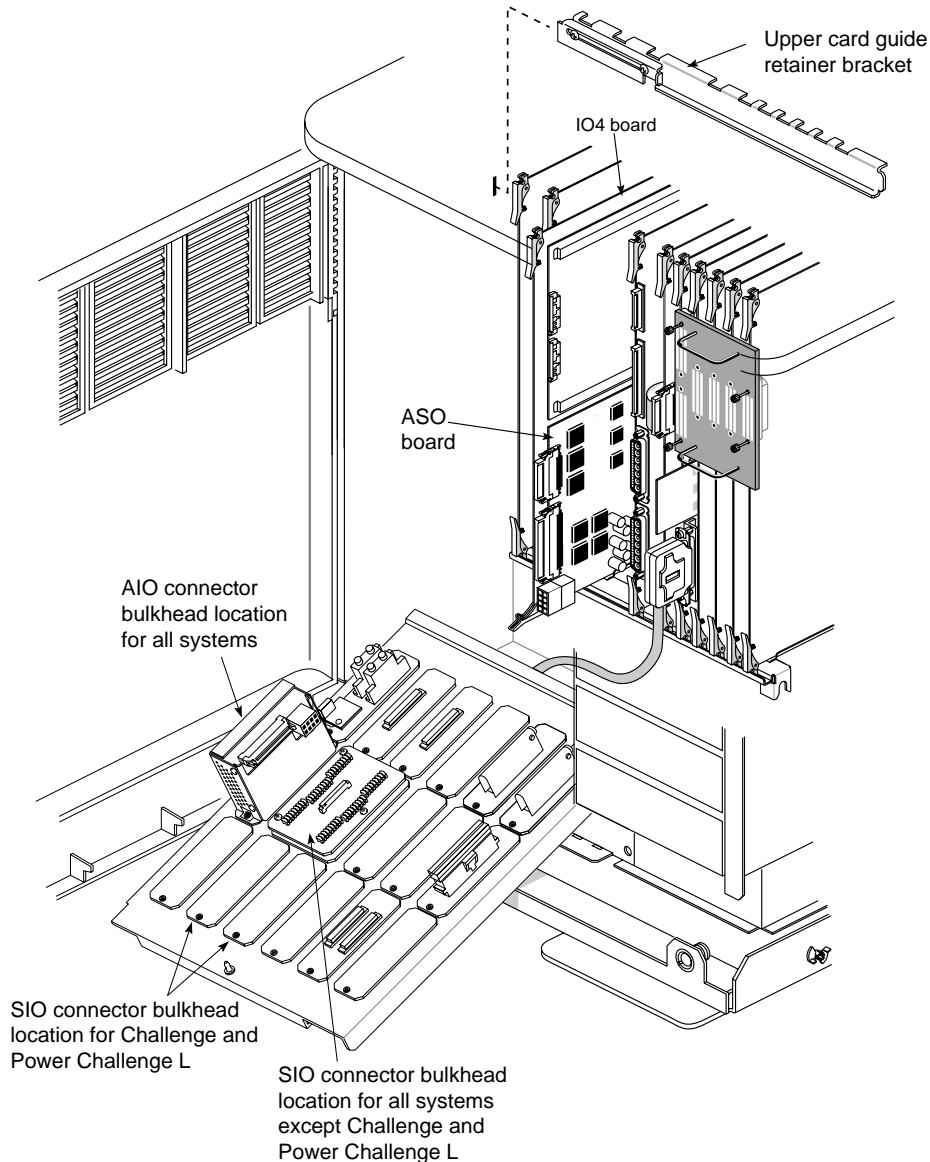

Note: This positioning normally provides the most room for cabling and also does not interfere with existing IO4 SCSI cables.

2.4.4 Removing Boards in Slots 1 in 2 From a Deskside System

If you have a deskside system that sits at ground level, you must remove the AIO connector bulkhead whenever you need to remove an MC3 or IP19/IP21 board that is located in the first two left-hand slots (see Figure 2-8). Otherwise, the height of the AIO connector bulkhead prevents the boards from being removed from the cardcage.

Figure 2-8 AIO Connector Bulkhead Removal Reminder

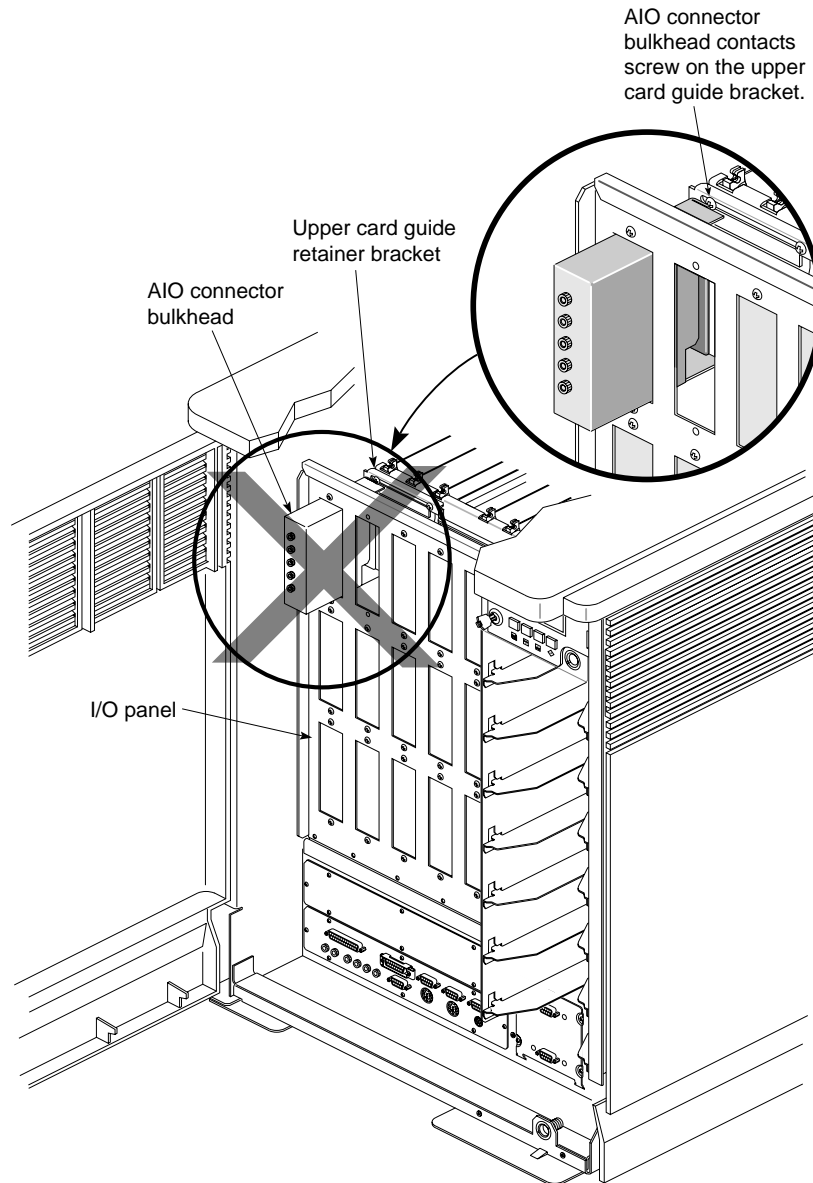

2.4.5 Connecting the Internal ASO Cables

There are three internal ASO cable assemblies (see Figure 2-9):

- AIO power harness (p/n 015-0239-001)
- 100-pin AIO cable assembly (p/n 018-0496-001)
- 60-pin SIO cable assembly (p/n 018-0495-001)

Figure 2-9 ASO Cable Assemblies

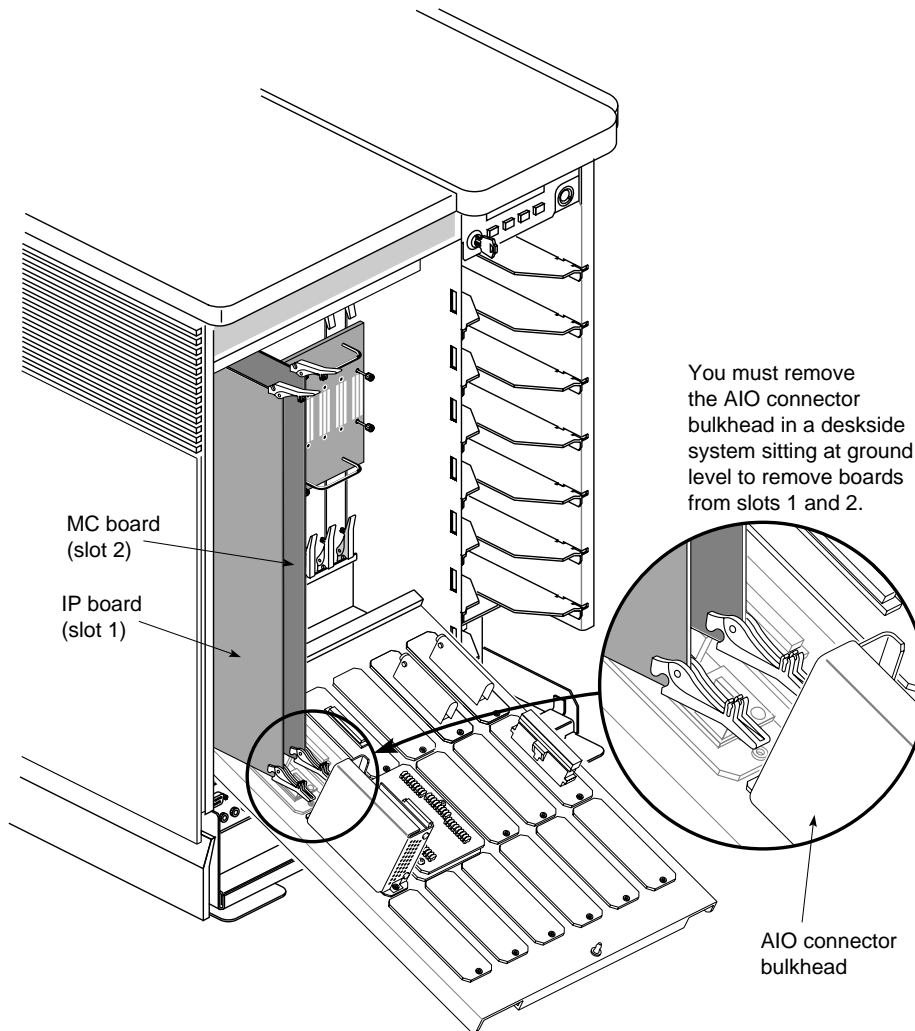

Follow the steps below and see Figure 2-1 and Figure 2-10 to attach the internal ASO cables to the ASO board and to the audio and serial connector bulkheads on the I/O panel.

1. Locate the 100-pin AIO cable assembly (p/n 015-0239-001) and the AIO power harness (p/n 015-0239-001). See Figure 2-9.
2. Attach the AIO cable assembly and power harness to the corresponding ASO board connectors and I/O panel connector bulkhead, as shown in Figure 2-1 and Figure 2-10.
3. Locate the 60-pin SIO cable assembly (p/n 018-0495-001). See Figure 2-9.
4. Attach the SIO cable assembly to the corresponding ASO board connector and I/O panel connector bulkhead, as shown in Figure 2-1 and Figure 2-10.
5. After you have attached the ASO cables, you may have a morass of cables. A typical cabling scenario is shown in Figure 2-11. Carefully tuck excess cabling into the sides of the system so that the cables do not prevent you from closing the I/O door.

Note: The ASO cable lengths were determined after conducting worst-case cabling tests in a rackmount system.

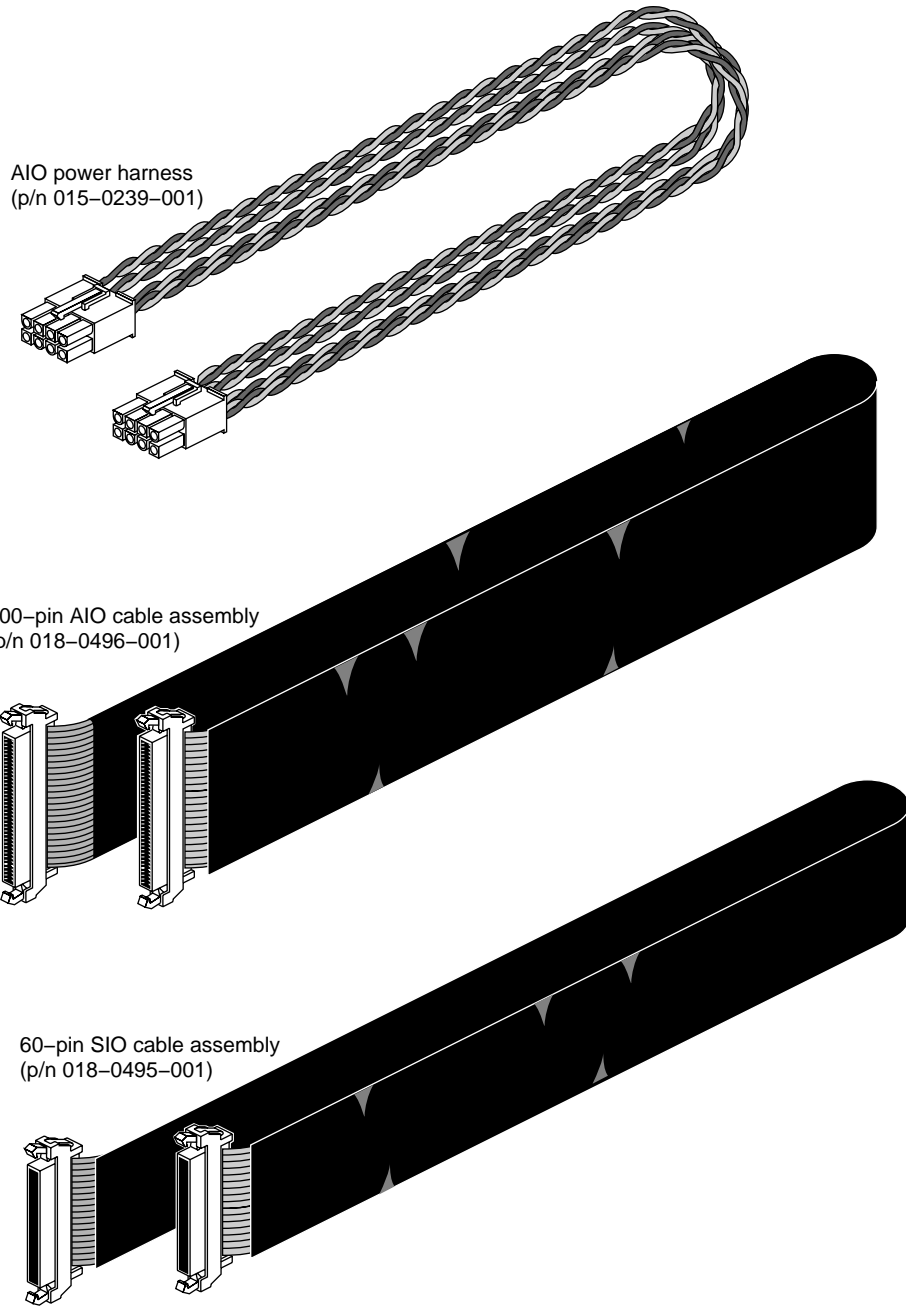

6. Afterwards, carefully close the I/O panel and make sure that the cables are not pushing excessively against any board connectors and causing possible damage.

Figure 2-10 Connecting the ASO Cables

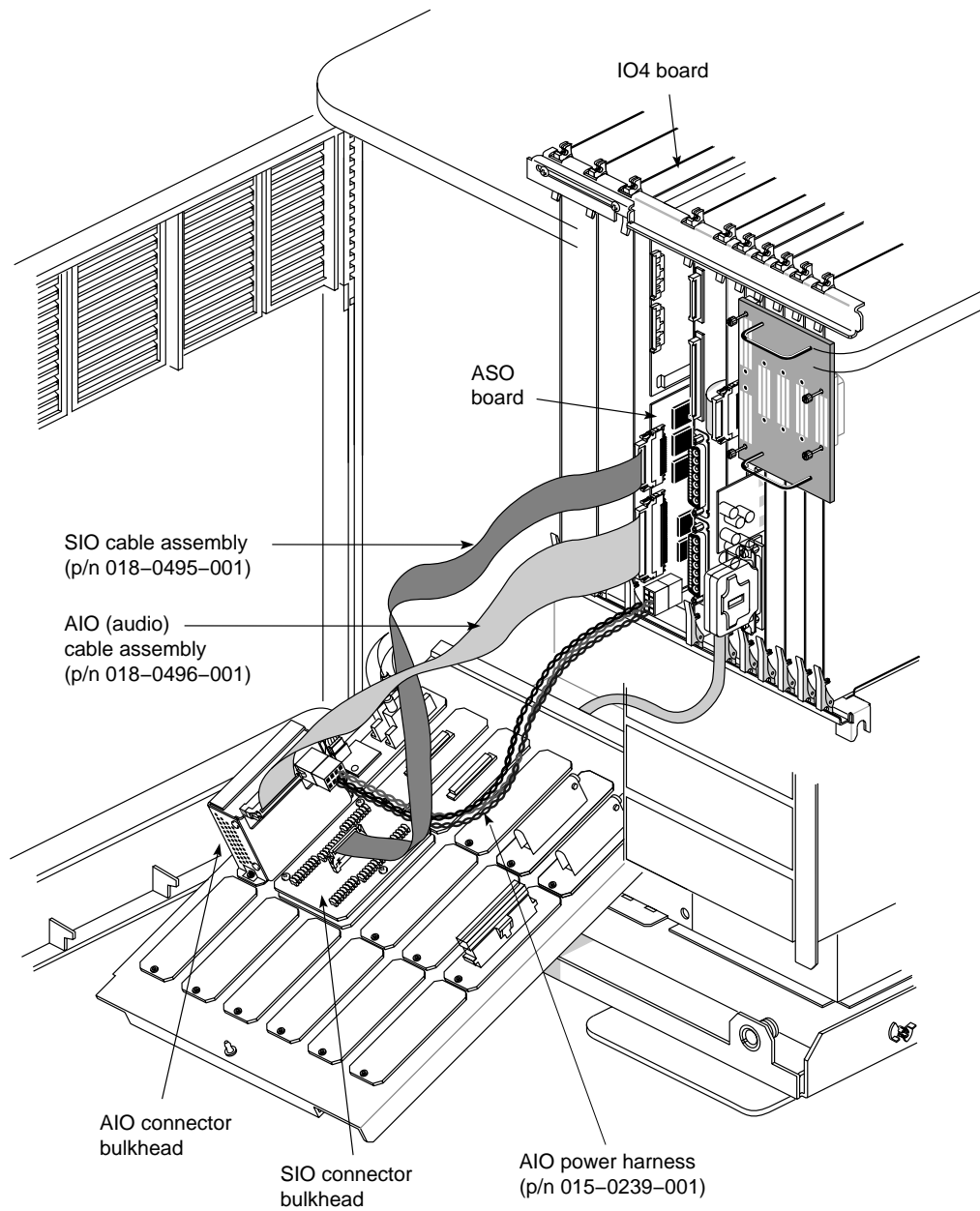
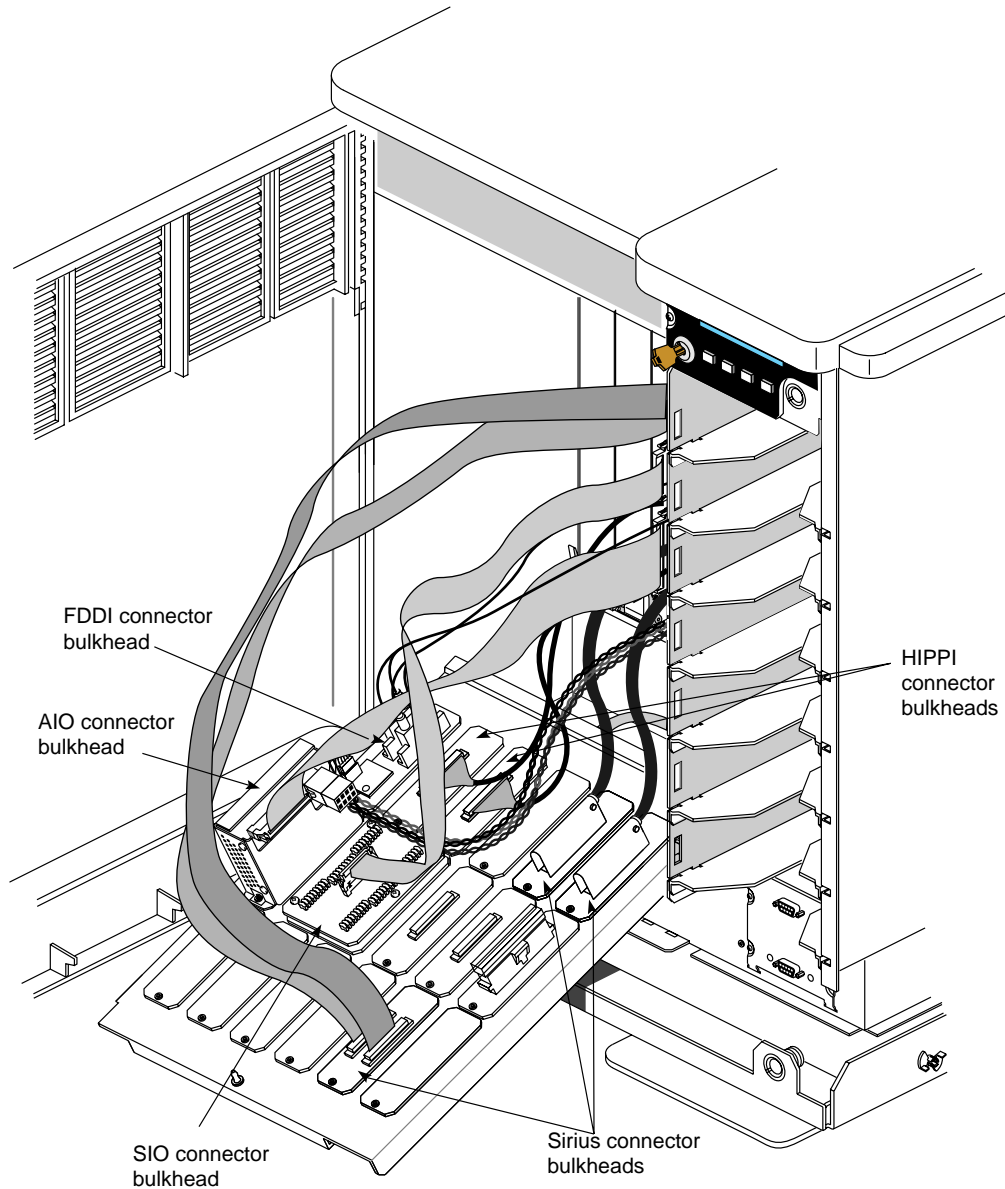

Figure 2-11 A Typical Cabling Scenario

2.5 Installing the ASO Software

The ASO software installs through *inst* from a CD-ROM. There are three pieces of software that need to be installed:

- *aso.sw.ser*



- *aso.man.ser*
- patch 395 for an IRIX 5.3 system *or* patch 397 for an IRIX 6.0.1 system

Follow these steps to install the ASO software.

1. After installing the ASO hardware, flip the circuit breaker to **ON**, wait for one minute, then turn the key switch on the front to **ON**.
2. Boot and log into the system as superuser.
3. If required, mount the CD-ROM drive as shown in the following example:

```
# mount -r /dev/dsk/dks0dms7/CDROM
```

where *n* is the address of the CD-ROM reader.

4. Install the first of three ASO subsystems using *inst*:

```
# inst -f /CDROM/dist/aso.sw.ser
```

5. You should then see a display similar to the following:

```
Default location of new software is xxxxxx
```

```
If you are a first-time inst user, give the command "help beginner".
```

```
Inst Main Menu
```

- | | |
|-------------------------------|---|
| 1. from [source] | Specify location of software to be installed |
| 2. list [keywords] [names] | Display information about software subsystems |
| 3. go | Perform software installation and removal now |
| 4. install [keywords] [names] | Select subsystems to be installed |
| 5. remove [keywords] [names] | Select subsystems to be removed |
| 6. keep [keywords] [names] | Do not install or remove these subsystems |
| 7. step [keywords] [names] | Enter interactive mode for |
| install/remove/keep | |
| 8. versions [args] | Get information about installed software |
| 9. help [topic] | Get help in general or on a specific word |
| 10. admin | Go to the Administrative Commands Menu |
| 11. quit | Terminate software installation |

6. At the *inst* main menu, type **list** to verify the software:

```
Inst> list
```

7. After verifying that the correct software is called out, type **go** to begin installation.

```
Inst> go
```

8. When the installation is complete, install the second of three subsystems:

```
Inst> install aso.man.ser
```

9. Afterwards, repeat steps 6 and 7 to complete the installation of the second subsystem.

10. When done, install the third subsystem: patch 395 for an IRIX 5.3 system *or* patch 397 for an IRIX 6.0.1 system.

```
Inst> install patchSGxxxx
```

where *xxxx* is the patch number you wish to install.

Caution: You must specify the required patch number, since you cannot install all the patches at one time. For example, if you give the command *install default*, you see the error `desktop_tools.sw.tools requires desktop_eoe.sw.fam 1019999999`.

11. Afterwards, repeat steps 6 and 7 to complete the installation of the final subsystem.

12. Once the patch is installed, enter **quit** to exit from *inst*.

13. To reconfigure the kernel, type the following command (as superuser):

```
# autoconfig
```

14. Reboot the system, when you are done.

2.6 Important S/W Installation Information for IP21 Systems

If you have an IP21 system, you will not be able to use the audio capabilities until you run the *MAKEDEV* command as follows:

1. At the IRIX prompt, type `cd /dev`.
2. Afterwards, become superuser.
3. Type `./MAKEDEV`. This command adds/updates the required files to the */dev/hdsp* directory such as *hdsp0master*.

Note: The *MAKEDEV* command takes about 10 minutes to execute.

4. From the */dev/hdsp* directory, type `ls -l` to check if the files are present. Also note if the time and date of the files have been updated.

2.7 Verifying Installation

To verify installation, type `hinv` at an IRIX shell and check that the ASO hardware is listed.

You should see a display similar to the following:

```
.....  
ASO 6-port Serial board [b]: revision [d].[e].[c], Ebus slot [s], IO Adapter [a]  
Iris Audio Processor: version A2 revision x.x.x  
.....
```

where:

[b] is the board number. It will automatically be 0 at first product release.

[d] is the DANG revision (see Figure 1-2), for example revision B or C.

[e] is the external CPLD revision (see Figure 1-2).

[c] is the internal (Silicon Graphics) CPLD revision (see Figure 1-2).

[s] is the Ebus slot number for example, 3 (typically) for a deskside system.

[a] is the IO adapter number, for example, 5 or 6 (see Figure 2-2).

Note: If the board is not listed, reinstall the product (the board and all cables) making sure everything is firmly seated and tightly connected.

2.8 Testing the Ports

To test some of the audio and serial ports of the ASO, you need:

- a headphone and a microphone (if available) for the audio tests
- an ASCII terminal for the serial test

2.8.1 Audio Tests

Follow these instructions to test the ASO audio ports.

1. If it is available on the system, bring up the Audio Panel from the Desktop toolchest or type `apanel` from a shell.
2. Plug a headphone into the headphone port of the AIO connector bulkhead.
3. Go to a directory that contains sounds such as `/usr/lib/sounds/prosonus/instr`.
4. Type `playaiff <sound filename>` and listen for the sound. Check the volume control by adjusting the volume through the Audio Panel (if available).
5. To test the microphone input, select the audio confidence tests under the Run Confidence Tests in the System toolchest.
6. Plug the microphone and headphone into the appropriate ports on the bulkhead.
7. Double-click the audio test to check out the microphone port.

2.8.2 Serial Tests

Follow these instructions to test the ASO serial ports.

1. Connect an ASCII terminal to a serial port on the ASO serial connector bulkhead. Ensure that the terminal is set for: 9600 baud (full duplex), XON/XOFF handshaking, 8 bits, and 1 stop bit.
2. On the ASCII terminal, press `<return>` and `<break>` until the terminal responds. Afterwards, login and then logout. Follow steps 1 and 2 to check out the other serial ports.

Chapter 3

Configuring the Ports

This chapter briefly describes how to configure the serial ports for RS-232 or RS-422 operation and how to set the baud rates. This chapter also shows how to use the audio ports.

Note: For additional information, see the *Audio/Serial Option User's Guide* (p/n 007-2645-xxx).

3.1 Using Serial Devices

The 9-pin D-sub serial connectors and signal pinouts are exactly the same as the DB-9, RS-232 connectors on existing Challenge, Onyx, Reality Station, POWER Challenge, and POWER Onyx systems (see Appendix A). You can therefore take RS-232 cables from those systems and use them for ASO board operation. The ASO serial ports are software selectable between RS-232 and RS-422 operation.

Caution: You cannot use the RS-422 cables from existing systems for operation on the ASO board ports.

Table 3-1 shows how the ports correspond to IRIX device files (see also Figure 3-1).

RS-232 Device	RS-422 Device	High-Speed (Memory-Mapped) Device
/dev/tty[dfm]72	/dev/tty4[dfm]72	/dev/aso_mmap/tty72
/dev/tty[dfm]73	/dev/tty4[dfm]73	/dev/aso_mmap/tty73
/dev/tty[dfm]74	/dev/tty4[dfm]74	/dev/aso_mmap/tty74
/dev/tty[dfm]75	/dev/tty4[dfm]75	/dev/aso_mmap/tty75
/dev/tty[dfm]76	/dev/tty4[dfm]76	/dev/aso_mmap/tty76
/dev/tty[dfm]77	/dev/tty4[dfm]77	/dev/aso_mmap/tty77

Table 3-1 How the Serial Ports Correspond to IRIX Device Files

Figure 3-1 SIO Ports for Audio/Serial Option

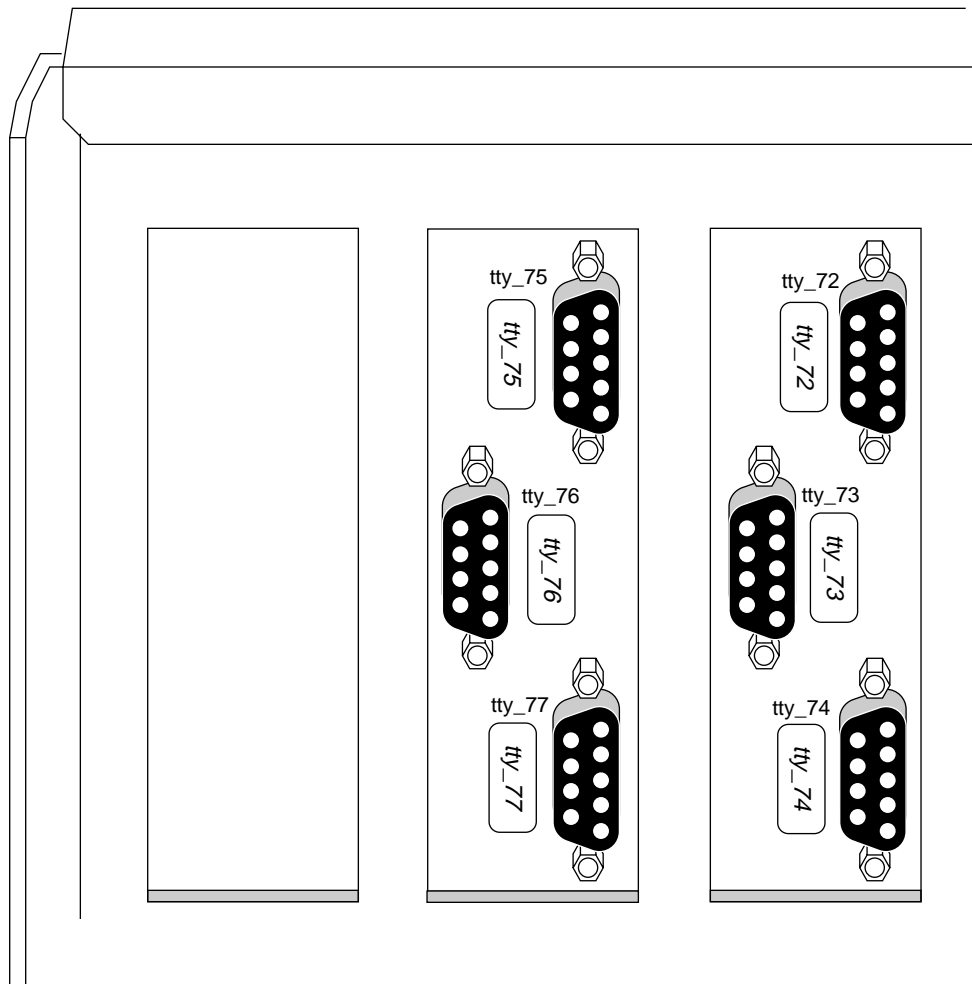

3.1.1 Serial Modes and Baud Rates

Table 3-2 shows how you can use any of the six ASO serial ports.

Serial Mode	Device Files	Maximum Baud Rate	Driver Required
RS-232	<code>/dev/tty[dfm]72</code> through <code>/dev/tty[dfm]77</code>	115.2 Kbaud/sec (See Caution below.)	Silicon Graphics supplied ASO driver <code>/var/sysgen/boot/asoser.o</code> . (See Note below.)

Table 3-2 ASO Serial Port Device Entries and Baud Rates

Serial Mode	Device Files	Maximum Baud Rate	Driver Required
RS-422	<code>/dev/tty4[dfm]72</code> through <code>/dev/tty4[dfm]77</code>	115.2 Kbaud/sec (See Caution below.)	Silicon Graphics supplied ASO driver <code>/var/sysgen/boot/asoser.o</code> . (See Note below.)
High-speed, memory-mapped	<code>/dev/aso_mmap/tty72</code> through <code>/dev/aso_mmap/tty77</code>	115.2 Kbaud/sec (See Caution below.)	Silicon Graphics supplied ASO driver <code>/var/sysgen/boot/asoser.o</code> . (See Note below.)

Table 3-2 ASO Serial Port Device Entries and Baud Rates

Caution: Baud rates beyond 115.2 Kbaud/sec are not supported by Silicon Graphics.

Note: Baud rate applications beyond 38.4 Kbaud/sec require customer-modified applications.

3.1.2 Setting Up the Serial Ports

You can set up the standard serial ports through use with IRIX by editing the `/etc/inittab` and other configuration files as described in the *IRIX Advanced Site and Server Administrator's Guide* (p/n 007-0603-xxx).

Do not use the graphical Port Setup tool, available from the Toolchest and System Manager to set up the ASO serial ports. The Port Setup tool does not recognize the ASO serial ports. This tool is documented in "Setting Up Peripheral Connections," in the *Personal System Administration Guide* (p/n 007-1366-xxx).

3.2 Audio Devices

Table 3-3 describes the ASO audio ports.



Audio Port	Function
Digital Input/Output 	Serial digital audio input and output.
Headphone Output/Line Output 2 	Stereo output jack. To support a four-channel configuration, the Headphone Output becomes Line Output 2.

Table 3-3 Audio Connections

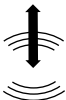

Audio Port	Function
Line Output 1 	Stereo jack for analog audio output to a tape deck, CD player, or similar destination.
Line Input 1 	Stereo jack for analog audio input from a tape deck, CD player, or similar source.
Microphone Input/Line Input2 	Microphone jack that supports stereo. To support a four-channel configuration, the Microphone input becomes Line Input 2.

Table 3-3 Audio Connections

There are a number of Silicon Graphics audio utilities that are available. For additional information, see the *Audio/Serial Option User's Guide* (p/n 007-2645-xxx) or the *Media Tools User's Guide*, and the *Media Control Panels User's Guide*.

Caution: The audio connector jacket should be no longer than about 1.75" to 2" (4.4 cm to 5 cm), because the I/O door can smash against longer connectors when the door is closed (see Figure 3-2.) To avoid damaging audio cables and connectors, it is recommended that the customer use right-angle audio connectors whenever possible.

Figure 3-2 Possible Audio Connector Problem With I/O Door

Caution: It's highly recommended that right-angle audio connectors be used to prevent possible cable damage. Remember, the I/O door should always remain closed for proper FCC shielding.

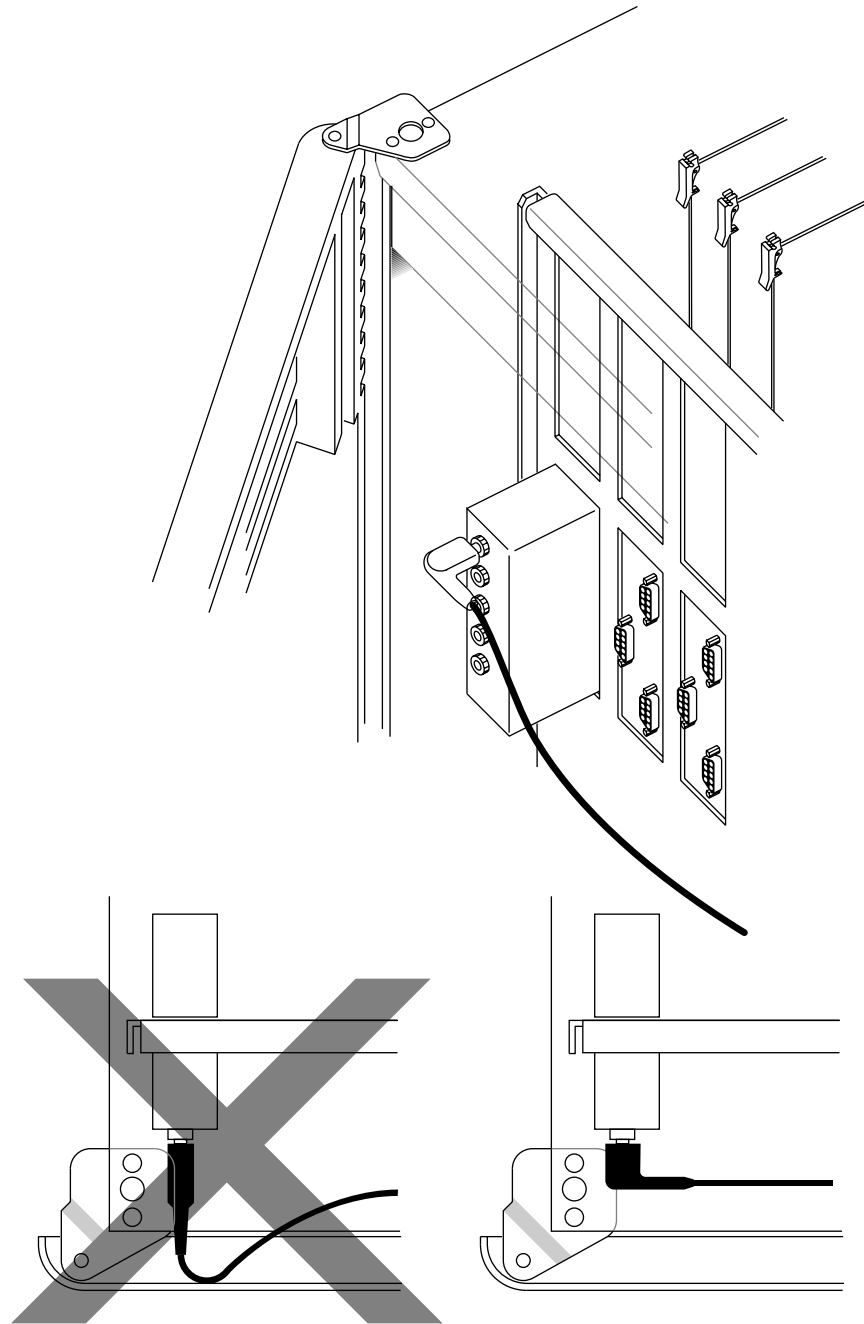

Appendix A

Serial and Audio Serial Connector Pinout Information

This appendix provides detailed connector pinout information for the serial and audio ports available through the ASO board.

A.1 Serial Connectors

Table A-1 shows the pinouts for the ASO serial connectors. These 9-pin, D-sub serial connectors and signal pinouts are exactly the same as the DB-9 RS-232 connectors on existing Challenge, Onyx, POWER Challenge, POWER Onyx, and Reality Station systems. The ASO serial port is software selectable between RS-232 and RS-422 operation.

Caution: You cannot use the RS-422 cables from existing systems for operation on the ASO board ports.

Description	Pin	RS-232 Mode	RS-422 Mode
9-pin D-sub receptacle. See Figure A-1.	1	NC	TX_H
	2	TXD	TX_L
	3	RXD	RX_L
	4	RTS	RTS
	5	CTS	CTS
	6	NC	RX_H
	7	GND	GND
	8	DCD	DCD
	9	DTR	DTR

Table A-1 ASO Serial Connectors

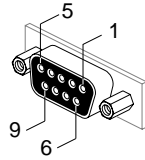

Figure A-1 ASO Serial Connector Pin Locations

Connector	Tip	Ring	Sleeve
Digital Input/Output	Out	In	GROUND
Headphone Output/Line Output 2	L	R	GROUND
Line Output 1	L	R	GROUND
Line Input 1	L	R	GROUND
Microphone Input/Line Input 2	L	R	GROUND

Table A-2 Audio Port Connectors