

# Triple Keyboard Option Installation Instructions

Document Number 108-0125-001

---

**Contributors**

Written by Carolyn Curtis

Illustrated by Dan Young and Cheri Brown

Edited by Christina Cary

Production by Laura Cooper

Engineering contributions by Robert Keller, Reuel Nash, Suzanne Jones, Paul Everhardt, Susan Tellep, and Todd Longbottom.

---

**© Copyright 1994, Silicon Graphics, Inc.— All Rights Reserved**

This document contains proprietary and confidential information of Silicon Graphics, Inc. The contents of this document may not be disclosed to third parties, copied, or duplicated in any form, in whole or in part, without the prior written permission of Silicon Graphics, Inc.

**Restricted Rights Legend**

Use, duplication, or disclosure of the technical data contained in this document by the Government is subject to restrictions as set forth in subdivision (c) (1) (ii) of the Rights in Technical Data and Computer Software clause at DFARS 52.227-7013 and/or in similar or successor clauses in the FAR, or in the DOD or NASA FAR Supplement. Unpublished rights reserved under the Copyright Laws of the United States. Contractor/manufacturer is Silicon Graphics, Inc., 2011 N. Shoreline Blvd., Mountain View, CA 94043-1389.

Silicon Graphics and IRIS are registered trademarks and IRIX, CHALLENGE, Onyx, and RealityEngine<sup>2</sup> are trademarks of Silicon Graphics, Inc.

**FCC Warning**

This equipment has been tested and found compliant with the limits for a Class A digital device, pursuant to Part 15 of the FCC rules. These limits are designed to provide reasonable protection against harmful interference when the equipment is operated in a commercial environment. This equipment generates, uses, and can radiate radio frequency energy and, if not installed and used in accordance with the instruction manual, may cause harmful interference to radio communications. Operation of this equipment in a residential area is likely to cause harmful interference in which case the user will be required to correct the interference at his or her own expense.

**Attention**

This product requires the use of external shielded cables in order to maintain compliance pursuant to Part 15 of the FCC Rules.

**Triple Keyboard Option Installation Instructions  
Document Number 108-0125-001**

**Silicon Graphics, Inc.  
Mountain View, California**

# Contents

## About These Instructionsix

1. **Kit Contents**1-1
2. **Installing the Option**2-1
  - 2.1 Preparing the Chassis2-2
  - 2.2 Attaching the IO4 Daughtercards and Installing the IO4 Boards  
2-4
  - 2.3 Attaching New 24W7 Cables in Cardcage 32-5
  - 2.4 Attaching TKO Panels to the I/O Doors2-6
  - 2.5 Attaching Ribbon Cables2-8
  - 2.6 Attaching Stereo Sync Cables2-9
  - 2.7 Cabling the Keyboards and Monitors2-11
  - 2.8 Cabling Serial Ports2-12
  - 2.9 Restarting the System and Installing the Software2-14
  - 2.10 Configuring the TKO2-14
  - 2.11 Testing the New Installation2-15



## Figures

<b>Figure 1-1</b>	TKO Kit Contents1-2
<b>Figure 2-1</b>	Triple Keyboard Option I/O Example Slot Placement2-2
<b>Figure 2-2</b>	Diagram of TKO Installation2-3
<b>Figure 2-3</b>	Attaching the Daughtercard to an IO42-4
<b>Figure 2-4</b>	Attaching 24W7 Cables in Cardcage 32-5
<b>Figure 2-5</b>	Filter Panel Labels2-6
<b>Figure 2-6</b>	TKO Filter Panels Installed2-7
<b>Figure 2-7</b>	Installing Ribbon Cables2-8
<b>Figure 2-8</b>	Attaching Stereo Sync Cables2-9
<b>Figure 2-9</b>	TKO Internal Cables Installed2-10
<b>Figure 2-10</b>	TKO External Cables Attached2-11
<b>Figure 2-11</b>	Serial Port Usage2-13



## Tables

<b>Table 1-1</b>	TKO Component Part Numbers1-3
<b>Table 1-2</b>	Marketing Codes Associated with TKO1-3
<b>Table 2-1</b>	Filter Panel Cabling2-6
<b>Table 2-2</b>	Cabling Keyboards for TKO2-11
<b>Table 2-3</b>	Serial Port Correspondences2-12



## About These Instructions

The Triple Keyboard Option (TKO) was designed for organizations that want as many as three people to use an Onyx™ rackmount system equipped with three RealityEngine<sup>2</sup>™ graphics pipes.

The Triple Keyboard Option consists of

- two daughtercards, one for the second IO4 board in the Onyx and one for the additional IO4 board supplied with the option
- two filterboards, each attached to an I/O panel to be mounted on the Onyx I/O door; each panel provides two powered RS-232 peripheral ports, one RS-422 port, and a keyboard connector
- two modified 24W7 cables to connect stereo sync to each filterboard
- two keyboards, including mice, and their external cables
- extension cables

For three keyboards for an Onyx rackmount with RealityEngine<sup>2</sup>, the customer must also order

- a third IO4 board for the system (marketing code HU-PC2)
- additional monitors (marketing code D-M21OPT or D-M20)
- IRIX™ version 5.2 for TKO on CD-ROM (marketing code SC4-TKO-5.2)

**Note:** This document is intended for use only by Silicon Graphics® System Support Engineers.

### Structure of This Document

The *Triple Keyboard Option Installation Instructions* consists of the following chapters:

- Chapter 1      “Kit Contents” depicts and describes all TKO components.  
Chapter 2      “Installing the Option” describes and illustrates how to install the TKO.

## Conventions

In command syntax descriptions and examples, square brackets ( [ ] ) surrounding an argument indicate an optional argument. Variable parameters are in *italics*. Replace these variables with the appropriate string or value.

In text descriptions, IRIX filenames are in *italics*. The names of IRIS<sup>®</sup> keyboard keys are printed in boldface typewriter font and enclosed in angle brackets, such as <Enter> or <Esc>.

Messages and prompts that appear onscreen are shown in typewriter font. Entries that are to be typed exactly as shown are in **boldface typewriter font**.

## *Chapter 1*

### **Kit Contents**

This chapter summarizes the contents of the Triple Keyboard Option (TKO) kit (marketing code HU-TKO). Figure 1-1 shows all TKO components.

**Note:** If parts are missing or if the kit contains incorrect parts, log a call with TAC.

Filterboard/panel assemblies

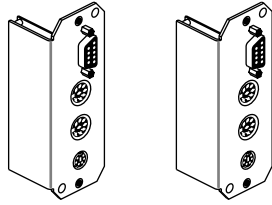

IO4 daughtercards

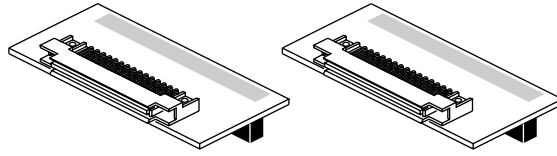

Keyboard/mouse assemblies

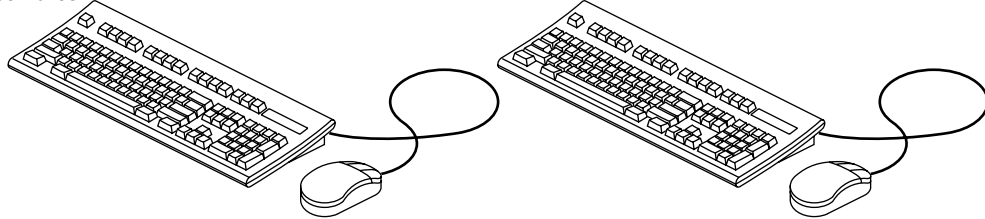

Keyboard auxiliary ribbon cables

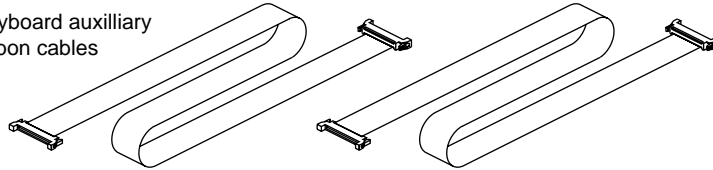

Extension cable for keyboard/mouse

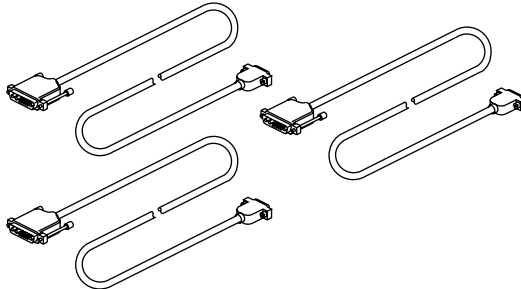

24W7 cables

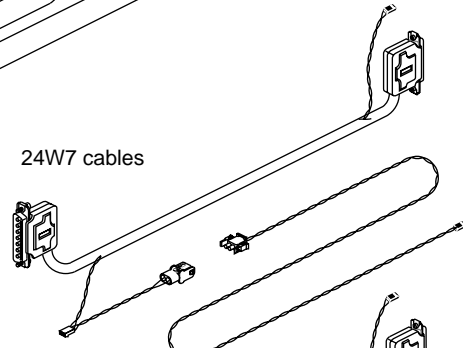

Jumper cable

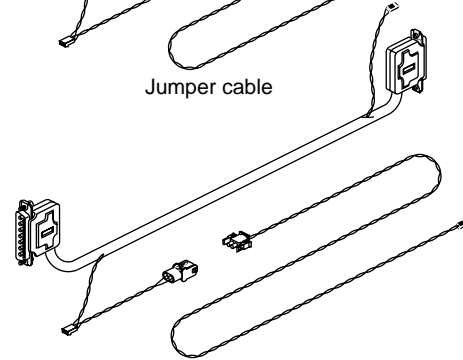

Extension cable for video

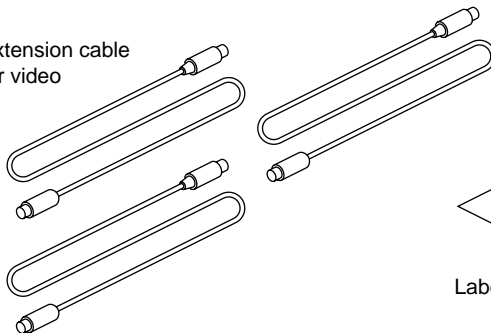

Label sheet

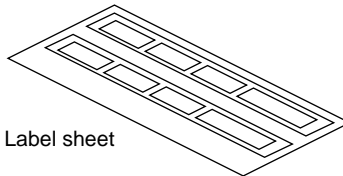

Figure 1-1 TKO Kit Contents

Table 1-1 lists part numbers and quantities for TKO components.

Component	Part Number	Quantity
Daughtercard (PCB ASSY, IO4 Adapter)	030-0340-002	2
Filterboard/panel assembly	013-1017-001	2
Keyboard auxiliary ribbon cable	018-0480-001	2
Modified 24W7	018-0482-001	2
Jumper cable (black and white twisted coax)	018-0485-001	2
Keyboard/mouse assembly	013-0657-001	2
75-foot video and keyboard extension cable, marketing code X8-VKC1, includes		3
Extension cable for keyboard/mouse	018-8095-002	
Extension cable for video	018-8094-002	
Label sheet for I/O panel plates	024-0860-001	1

**Table 1-1** TKO Component Part Numbers

Table 1-2 lists the marketing codes for products the customer must order to fit an Onyx rackmount with RealityEngine<sup>2</sup> with two keyboards or three keyboards.

Total Keyboards	Marketing Code	Description
2	3	
1	1	HU-TKO Triple Keyboard Option
0	1	HU-PC2 IO4 required for third keyboard
1	2	D-M21OPT or D-M20A Monitor
1	1	SC4-TKO-5.2 Software CD-ROM

**Table 1-2** Marketing Codes Associated with TKO

Note the following:

- The software for the TKO is a separate marketing code, not structured to the TKO itself. This software is IRIX 5.2 with modifications that support the TKO.
- The third IO4 is required for the third keyboard. Installing this board and its I/O panel are part of the TKO installation process. Make sure you know how to install the IO4, its panel, and cable; review or bring the *CHALLENGE™/Onyx Rackmount Installation Instructions* (108-7042-xxx) if necessary.



## Chapter 2

# Installing the Option

This chapter describes how to install the Triple Keyboard Option (TKO). The installation procedure is divided into the following steps:

1. Preparing the chassis
2. Attaching the IO4 daughtercards and installing the IO4 boards
3. Attaching new 24W7 cables in cardcage 3
4. Installing the TKO panels on the cardcage 2 I/O door
5. Attaching ribbon cables
6. Attaching stereo sync cables
7. Cabling the keyboards
8. Cabling serial ports
9. Restarting the system and installing the software
10. Configuring the TKO
11. Testing the new installation

**Note:** If the Onyx is running 5.1 or earlier, upgrade to 5.2 or later before proceeding.

Other Silicon Graphics manuals contain instructions for exchanging circuit boards. Make sure you have the appropriate one(s):

- *CHALLENGE™/Onyx Rackmount Installation Instructions* (108-7042-xxx)
- *CHALLENGE and Onyx Retrofit Instructions* (domestic version: 802-0107-002; international version: 802-0106-002)
- *Challenge/Onyx Rackmount Third Cardcage (CC3) Upgrade Instructions* (release note, 802-0105-xxx)

Make sure you have other pertinent release notes and Field Information Bulletins as well.

You need a flat-blade screwdriver and a Phillips screwdriver to install TKO.

## 2.1 Preparing the Chassis

Before you install the option, follow these steps:

**Caution:** Board components are extremely sensitive to electrostatic discharge. Use proper antistatic procedures while handling the board.

1. Make sure all users are off the target system. Shut down the system and open the chassis to expose the slots.
2. The three IO4 boards for TKO must all sit in cardcage 2; the second IO4 must go into slot 9 and the optional third IO4 must go into slot 7 for the kernel to recognize it.

A processor board, existing options, or both might have to be moved to accommodate all the IO4 boards. For example, one of the processor boards or a memory board can be moved to cardcage 1 if it has an appropriate vacant slot.

3. The TKO's two panels are installed on the cardcage 2 I/O door; plan where to install them. To avoid interfering with removal of VME boards, they should not be installed in the bottom row of slots. Figure 2-1 diagrams this placement.

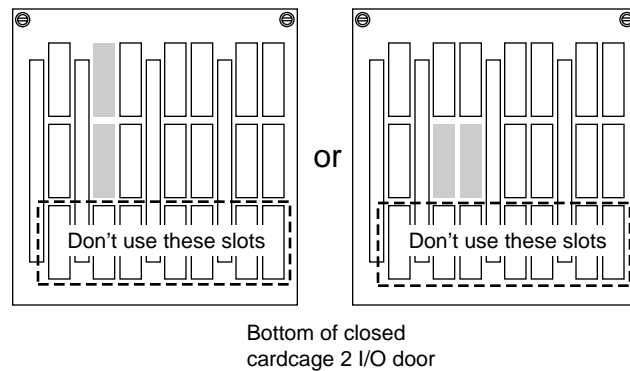

**Figure 2-1** Triple Keyboard Option I/O Example Slot Placement

Figure 2-2 diagrams a complete example installation.

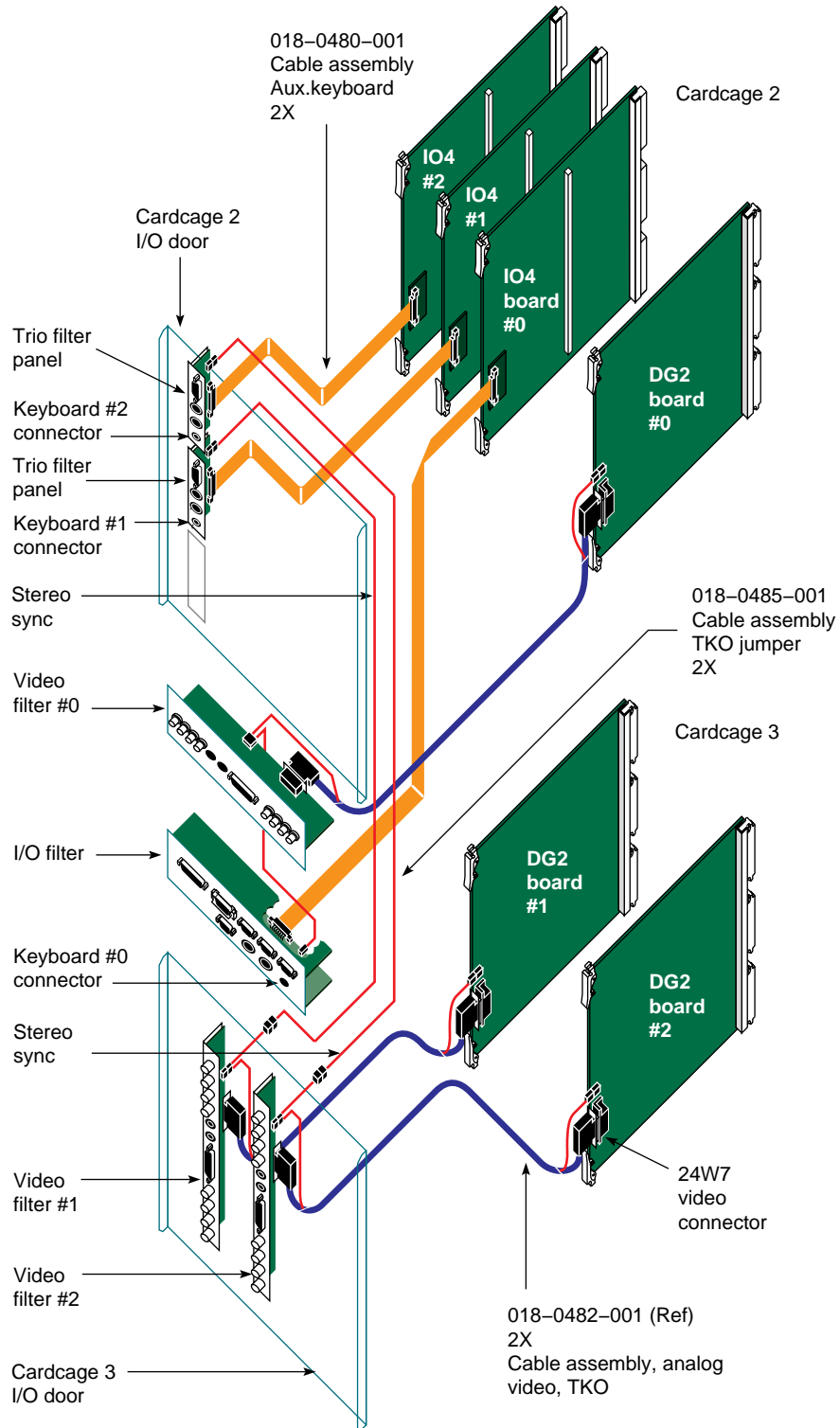
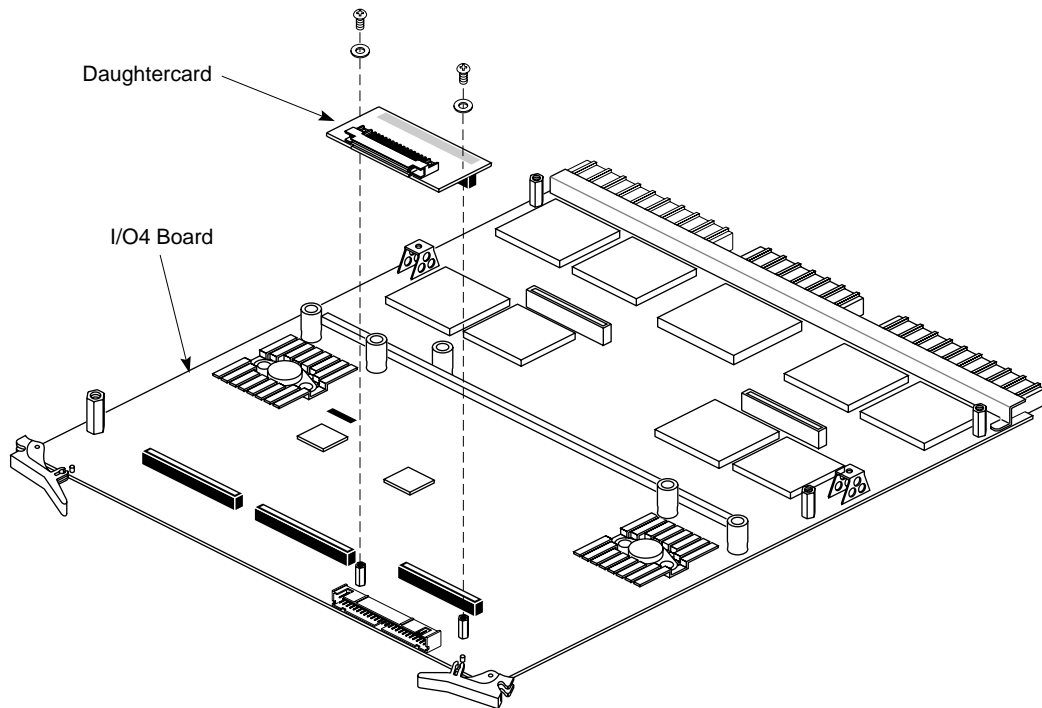

**Figure 2-2** Diagram of TKO Installation

## 2.2 Attaching the IO4 Daughtercards and Installing the IO4 Boards

The TKO includes two daughtercards, one for the second IO4 board in slot 9 in the system, and one for the additional IO4 (to be the third IO4 in the system). To attach the daughtercards, follow these steps:

1. Attach one of the daughtercards to the small edge connector on the optional third IO4. The connector (the only one that fits the daughtercard) is located on the side farthest from the LEDs. See Figure 2-3.



**Figure 2-3** Attaching the Daughtercard to an IO4

2. Remove the second IO4 board from slot 9 in cardcage 2.
3. Attach the daughtercard to the second IO4 board as shown in Figure 2-3.
4. Reinsert the IO4 you removed from the chassis into slot 9 of cardcage 2.
5. Insert the optional third IO4 into slot 7 of cardcage 2. If necessary, move a processor board or memory board to cardcage 1.
6. On the cardcage 3 I/O door, install the I/O panel for the optional third IO4. If necessary, install the I/O panel for the second IO4. Cable each panel to its IO4.

## 2.3 Attaching New 24W7 Cables in Cardcage 3

The two 24W7 cables with extra long stereo pigtail cables replace the existing 24W7 cables for graphics heads 1 and 2 in cardcage 3. The pigtail cables are thin black and white cables, twisted together; they might be encased in protective plastic sheaths.

**Note:** The existing 24W7 cable in cardcage 2 for graphics head 0 is left as is.

To install the new 24W7 cables for graphics heads 1 and 2, follow these steps:

1. In cardcage 3, detach the 24W7 from the DG2 boards in graphics heads 1 and 2, including the swap ready cable and the stereo sync cable.
2. Attach the modified 24W7s to the DG2 boards in graphics heads 1 and 2.
3. Attach the small twisted-pair swap ready cables to the appropriate connectors on the DG2s for graphics heads 1 and 2.
4. Slide each stereo sync connector onto the connector on the EF7 (video filter panel).
5. Attach a pigtail cable (p/n 018-0485-001) to the stereo sync connector on each EF7 cable. See Figure 2-4.

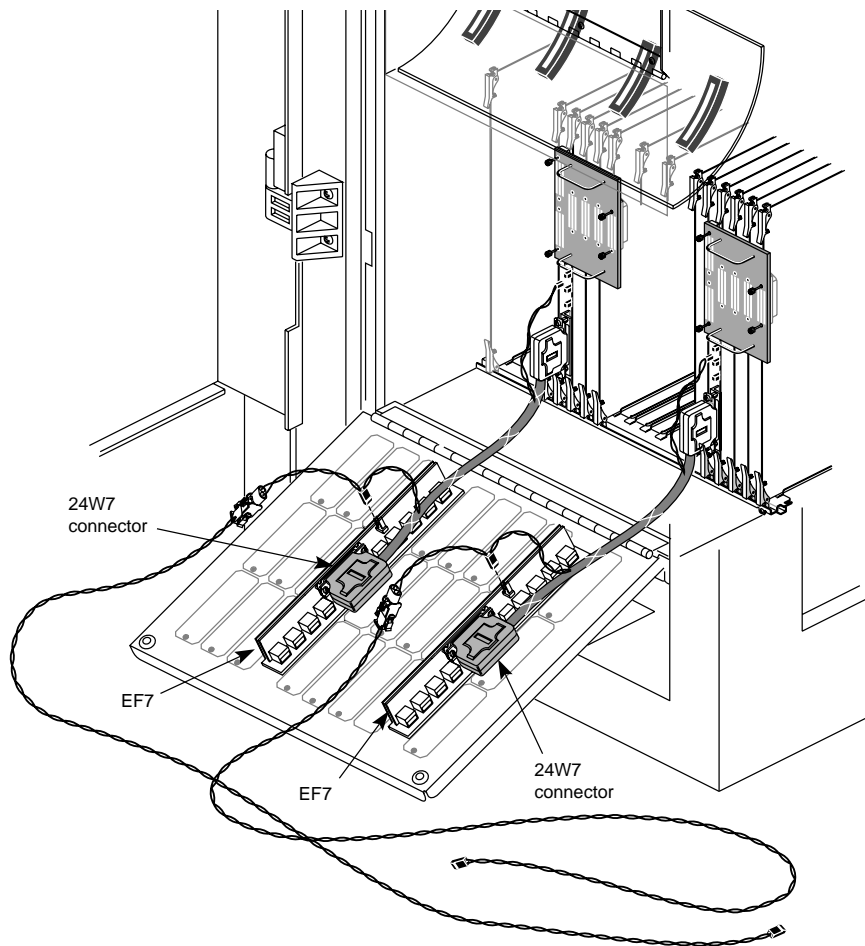

**Figure 2-4** Attaching 24W7 Cables in Cardcage 3

## 2.4 Attaching TKO Panels to the I/O Doors

TKO I/O for the additional keyboards is handled on two filter panels installed on the cardcage 2 I/O door.

The filterboard/panel assemblies themselves are identical, but must be differentiated by means of labels, because each filterboard is cabled to a specific IO4 and a specific graphics pipe, as outlined in Table 2-1. If necessary, refer to the layout diagrammed in Figure 2-2.

Filter Panel Label	To Be Cabled to IO4 (Ribbon Cable)	To Be Cabled to Graphics Head	Suggested Placement (Viewed with I/O Door Closed)
<b>AUX KBD 1</b>	Second	1 (cardcage 3)	Left or bottom
<b>AUX KBD 2</b>	Optional third	2 (cardcage 3)	Right or top

**Table 2-1** Filter Panel Cabling

Follow these steps:

1. Attach a label to each filter panel. Figure 2-5 shows the position on the panel where the label should be applied.

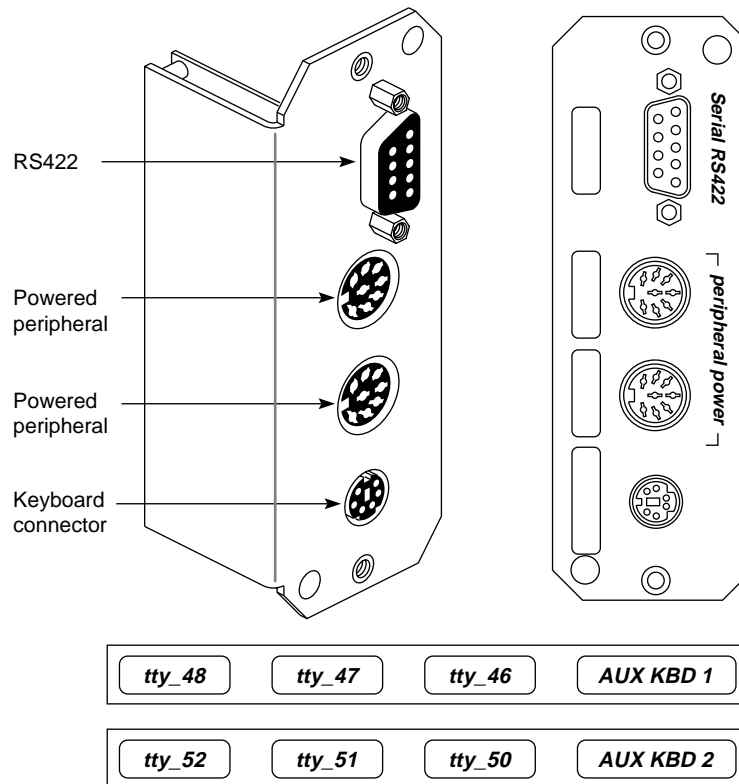
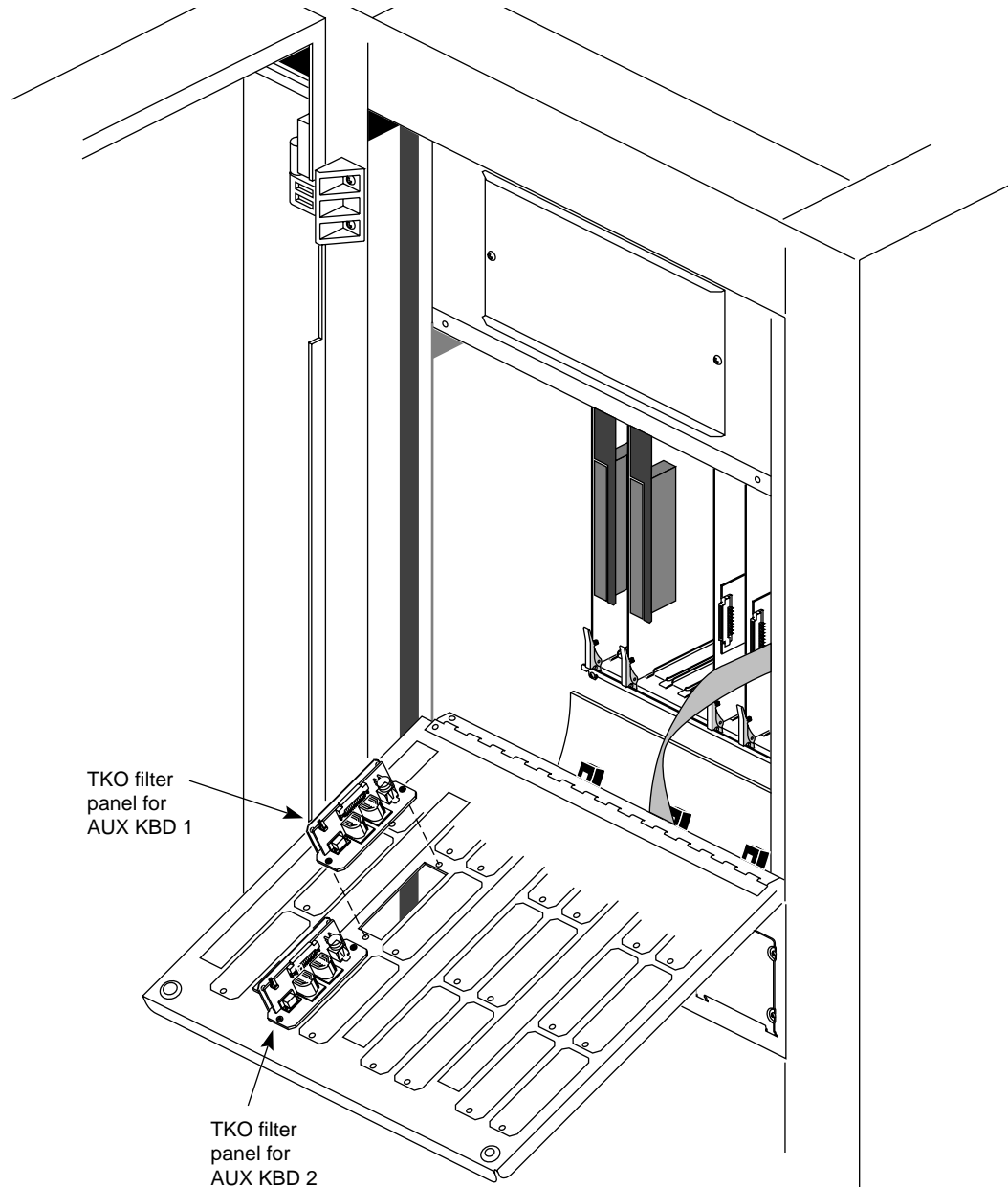

**Figure 2-5** Filter Panel Labels

2. On the cardcage 2 I/O door, remove the slot covers for the slots you have selected for the TKO I/O panels. Retain the screws.

**Note:** Do not use the bottom row of slots. Panels installed there make it difficult to remove VME boards.

3. Position the filter panel labeled **AUX KBD 1** on the bottom or left slot (as viewed with the I/O door closed); use the retained screws to screw it in.
4. Position the filter panel labeled **AUX KBD 2** on the top or the right slot (as viewed with the I/O door closed) whose cover you have removed; screw it in. Figure 2-6 shows the filter panels installed.

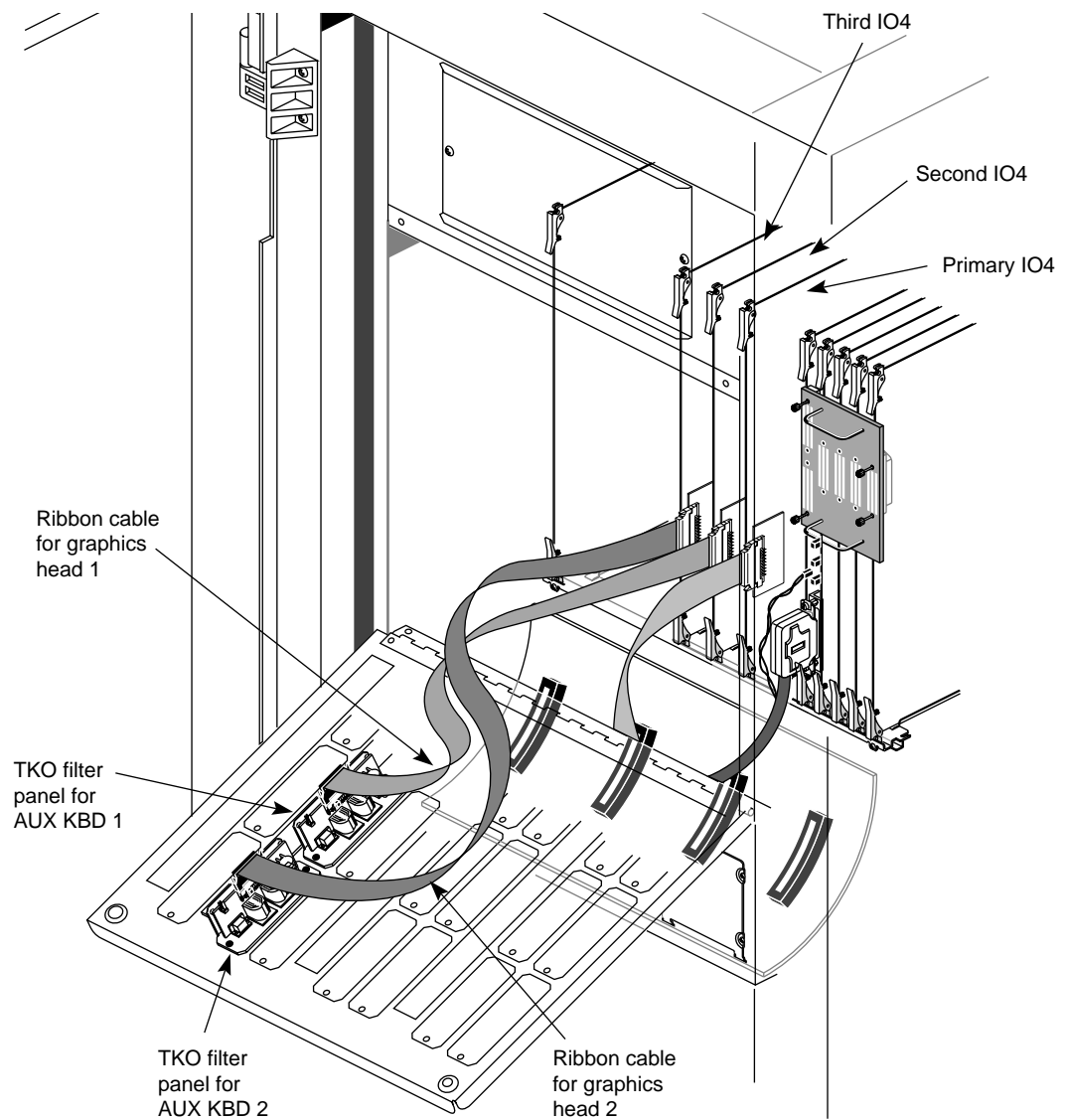

**Figure 2-6** TKO Filter Panels Installed

## 2.5 Attaching Ribbon Cables

Ribbon cables connect the daughtercards on the second IO4 and the optional third IO4 to the TKO filterboards. (Of course, the primary IO4 board's ribbon cable is already attached to the I/O panel at the bottom of cardcage 2.) Follow these steps:

1. Attach one end of a ribbon cable to the connector on the daughtercard on the second IO4. The connectors on the ribbon cables are keyed. Attach the other end to the bottom or leftmost filter panel on the cardcage 2 I/O door, as viewed with the I/O door closed. This should be the filter panel labeled **AUX KBD 1**.
2. Attach one end of the second ribbon cable to the connector on the daughtercard on the new third IO4. Attach the other end to the top or rightmost filter panel on the cardcage 2 I/O door (as viewed with the I/O door closed). This should be the filter panel labeled **AUX KBD 2**. Figure 2-7 shows the ribbon cables installed.

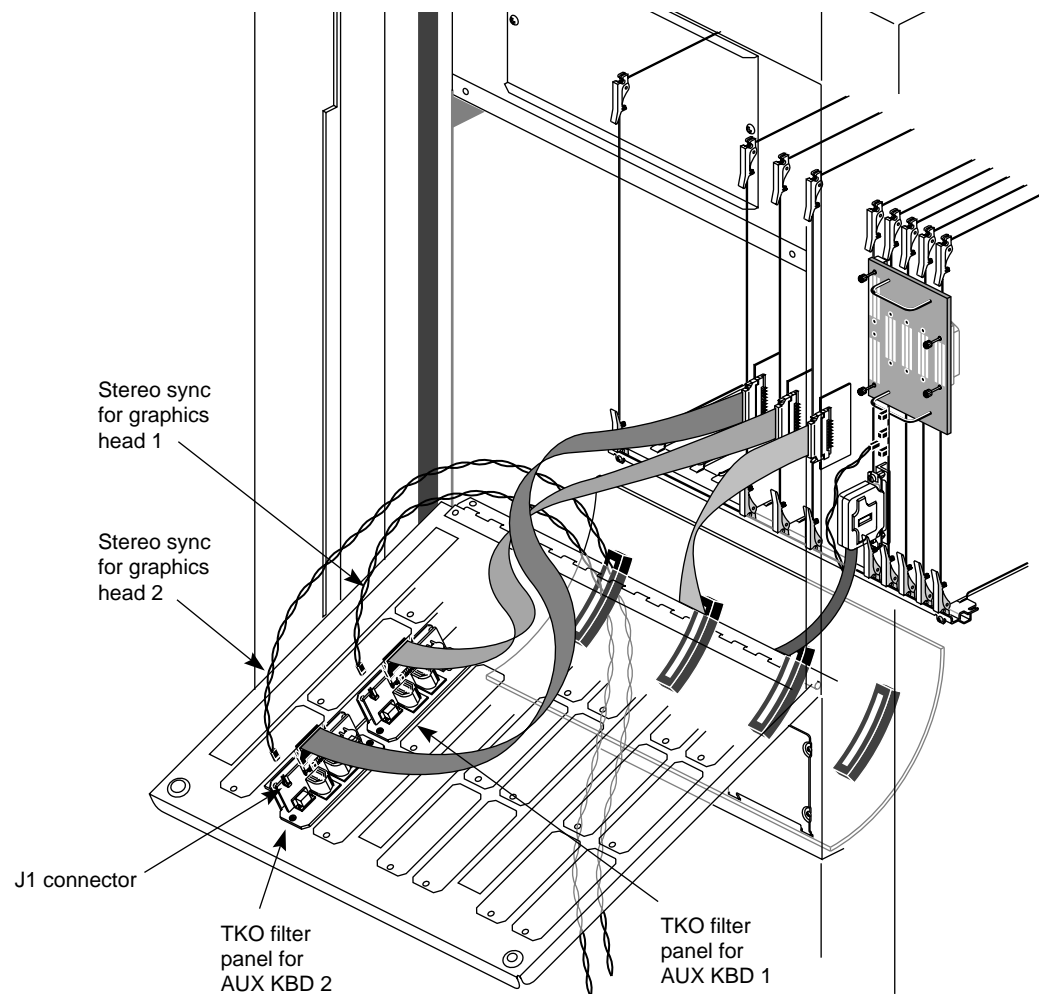

**Figure 2-7** Installing Ribbon Cables

## 2.6 Attaching Stereo Sync Cables

The long black-and-white twisted stereo sync pigtail cables that you plugged into the 24W7s must be plugged into the J1 connectors of the corresponding filterboards (on the I/O door of cardcage 2). Follow these steps:

1. Thread the pigtail cable from the 24W7 for graphics head 1 up through an appropriate slot in the cardcage 2 floor.
2. Slide the connector from the stereo sync cable onto the J1 connector on the **AUX KBD 1** filterboard. This should be the left or bottom filter panel, as viewed with the I/O door closed.
3. Thread the pigtail from the other 24W7 up through the slot; slide its connector onto the J1 connector on the **AUX KBD 2** filterboard. See Figure 2-8.



**Figure 2-8** Attaching Stereo Sync Cables

4. If necessary, tie down the pigtails to keep them out of the way. Use a tie wrap to tie the pigtail cables to a 24W7 cable in cardcage 3; use a sticky-back tie wrap to attach the pigtail cables loosely to the cardcage 2 wall. Figure 2-9 shows all internal cables, boards, and daughtercards installed.

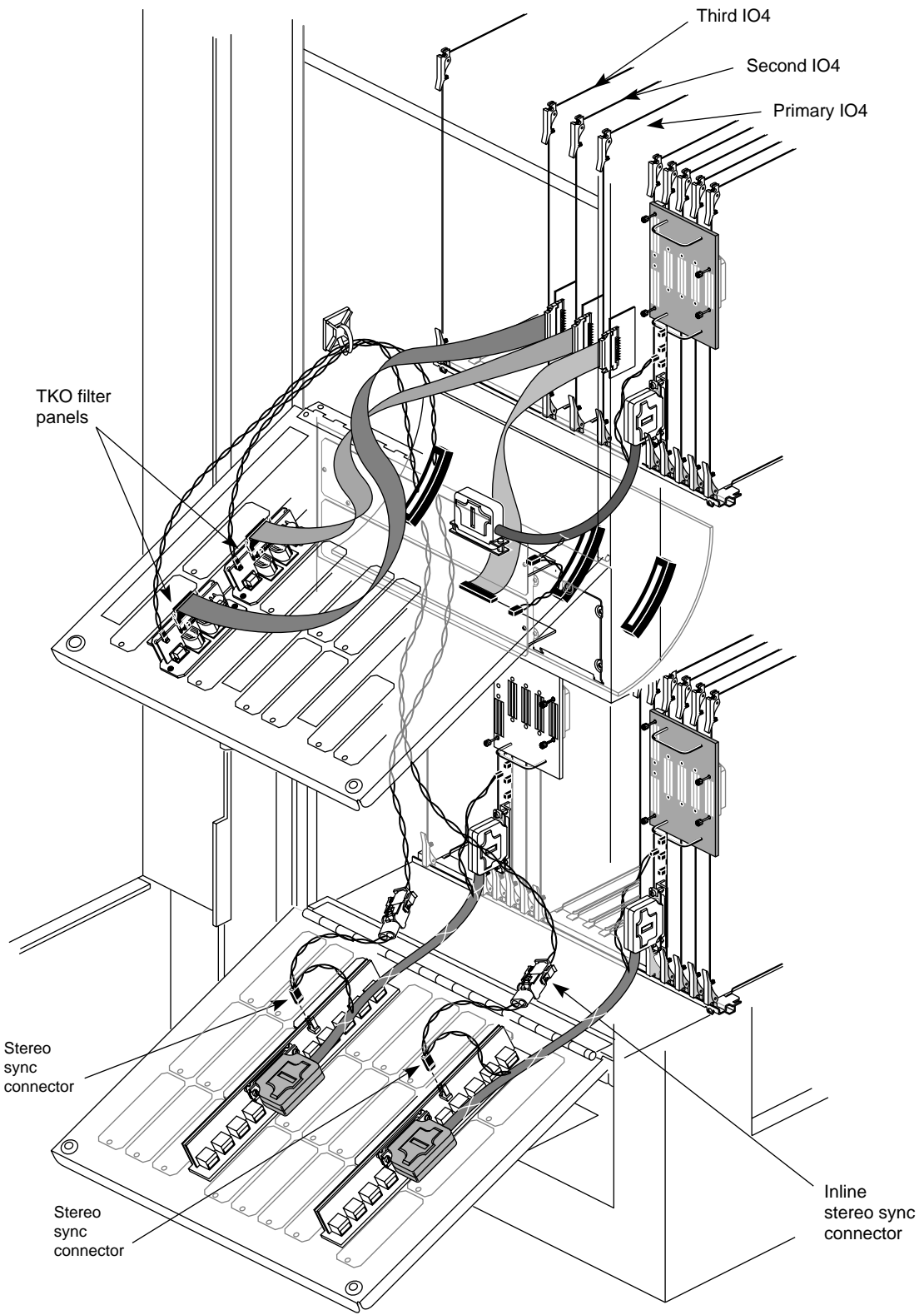

**Figure 2-9** TKO Internal Cables Installed

## 2.7 Cabling the Keyboards and Monitors

Determine where the customer wants the additional monitors, keyboards, and mice, and place them there. Make sure there is agreement on the numbering of the monitor and keyboard combinations.

The standard (suggested) configuration is summarized in Table 2-2.

Keyboard	Cabling
0 (Original)	Leave cabled as is to the original I/O panel, which is internally cabled to graphics head 0
1	Keyboard connector on the bottom or leftmost filter panel (AUX KBD 1) on the cardcage 2 I/O door, which is internally cabled to second IO4 and graphics head 1
2	Keyboard connector on the top or rightmost filter panel (AUX KBD 2) on the cardcage 2 I/O door, which is internally cabled to optional third IO4 and graphics head 2

**Table 2-2** Cabling Keyboards for TKO

Attach keyboard and monitor extension cables to the appropriate connectors on the I/O panels. Figure 2-10 diagrams attachment of the keyboard and monitor cables.

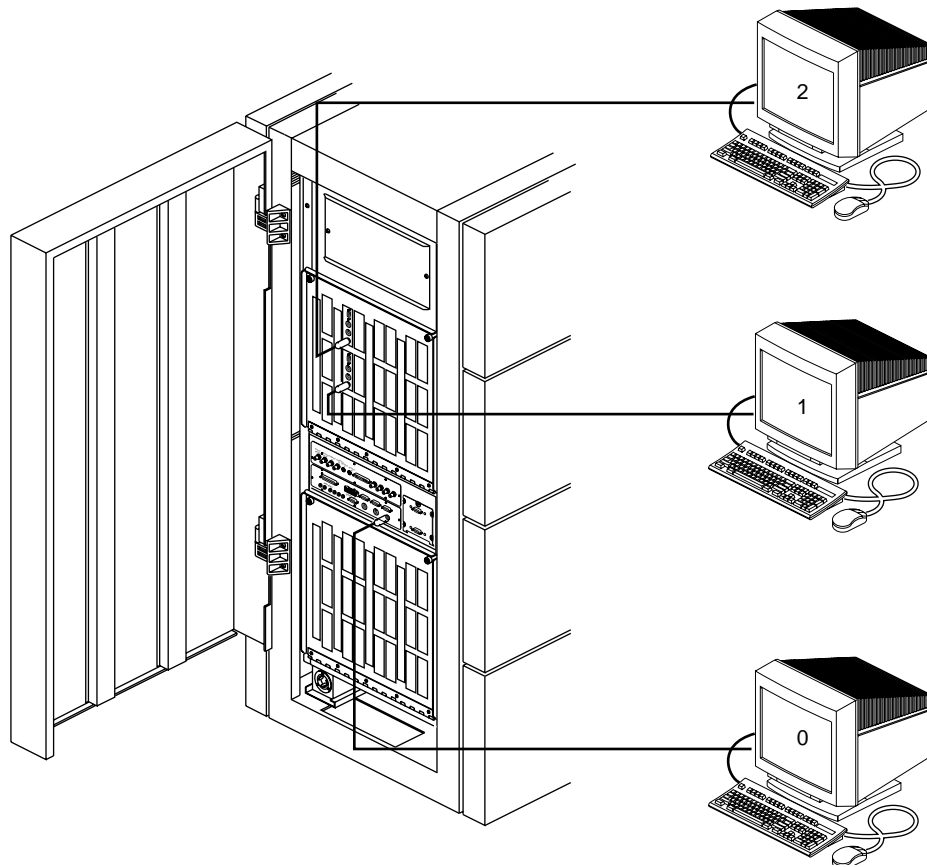

**Figure 2-10** TKO External Cables Attached

## 2.8 Cabling Serial Ports

The main I/O panel on the Onyx rackmount provides two types of ports for RS-232 peripherals—a 9-pin sub-D and a round 8-pin DIN connector. On the main I/O panel, these connectors are arranged one above the other; a bracket on the silkscreen links the two types of ports to indicate that only one should be used and not both.

However, the TKO filterboard panels have only the round 8-pin DIN connectors for powered peripherals (TTY 46 and TTY 47 on the TKO filter panel with **AUX KBD 1**, and TTY 50 and TTY 51 on the TKO filter panel with **AUX KBD 2**). The corresponding 9-pin sub-D connectors are on the standard I/O panels for the second and third IO4s. Although for the second and third IO4s the two types of serial ports are on separate panels, still only one or the other type of port can be used at one time, not both, just as in the case of the main I/O panel.

Table 2-3 summarizes serial port correspondences.

Round 8-pin DIN Connector Label (Powered Peripheral Port)	Corresponds to Sub-D Label (Unpowered Peripheral Port)
AUX KBD 1 panel: TTY_46	I/O panel for second IO4: TTY_46
AUX KBD 1 panel: TTY_47	I/O panel for second IO4: TTY_47
AUX KBD 2 panel: TTY_50	I/O panel for optional third IO4: TTY_50
AUX KBD 2 panel: TTY_51	I/O panel for optional thrid IO4: TTY_51

**Table 2-3** Serial Port Correspondences

**Note:** Use the serial port listed in one column or the other, not both. For example, if you use the round 8-pin DIN connector for TTY 46 on the **AUX KBD 1** panel, do not also use the 9-pin sub-D for TTY 46 on the I/O panel.

Figure 2-11 shows serial port usage.

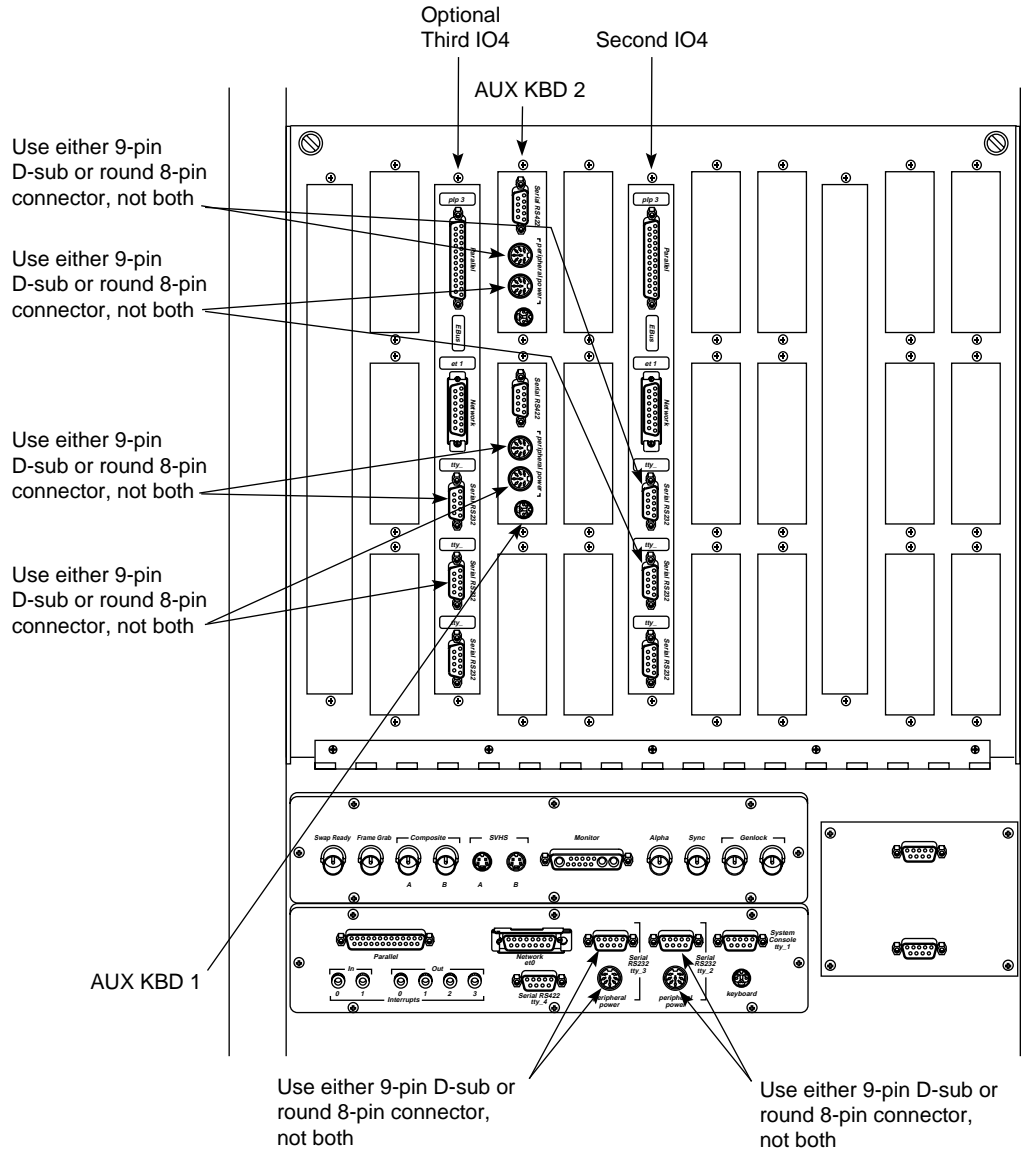

**Figure 2-11** Serial Port Usage

## 2.9 Restarting the System and Installing the Software

The version of IRIX 5.2 for TKO is on an *inst-able* CD-ROM that is ordered separately (marketing code SC4-TKO-5.2). TKO-specific differences are in *ee1*, *desktop\_ee1*, and *x\_ee1*.

Load the TKO software from the CD-ROM. Installing this software changes some of the IRIX system files, so backup is recommended.

The TKO software includes an example version of the *xdm Xservers* configuration file in */var/X11/xdm*, called *Xservers.3key*. The standard three-keyboard operation described in this chapter is mapped as follows:

- main keyboard mapped to graphics pipe 0
- auxiliary keyboard 1 mapped to graphics pipe 1
- auxiliary keyboard 2 mapped to graphics pipe 2

To set up IRIX for this operation, follow these steps:

1. Copy */var/X11/xdm/Xservers.3key* over */var/X11/xdm/Xservers*.
2. To execute the new *xdm* configuration file, rlogin, or log in through a serial port, and type as root:

```
/usr/gfx/stopgfx
/etc/killall xdm
/usr/gfx/startgfx
```

To set up the software for a different configuration, edit */var/X11/xdm/Xservers*, as explained in the next section.

## 2.10 Configuring the TKO

The TKO software includes an example version of the *xdm Xservers* configuration file called *Xservers.3key*; this file is located in */var/X11/xdm*. The example file shows how to modify the X servers file for three-keyboard operation.

The two files differ in the line(s) specifying X server configuration. The standard */var/X11/xdm/Xservers* file has one line defining the X server configuration:

```
:0 secure /usr/bin/X11/X [default options]
```

The */var/X11/xdm/Xservers.3key* file has three lines defining the X server configuration:

```
:0 secure /usr/bin/X11/X :0 -boards 0 -devdir /dev/input [default options]
:1 secure /usr/bin/X11/X :1 -boards 1 -devdir /dev/input1 [default options]
:2 secure /usr/bin/X11/X :2 -boards 2 -devdir /dev/input2 [default options]
```

These lines start X servers for all three keyboards. The *-boards n* parameter specifies the graphics pipe(s) to be used by the Xserver.

The configuration in *Xservers.3key* matches the standard hardware configuration described in this chapter: the main keyboard is mapped to graphics pipe 0, auxiliary keyboard 1 is mapped to graphics pipe 1, and auxiliary keyboard 2 is mapped to graphics pipe 2.

If the customer wants a different configuration, edit */var/X11/Xdm/Xservers*. For example, the following lines map the main keyboard to graphics head 0 and auxiliary keyboard 1 to graphics heads 1 and 2:

```
:0 secure /usr/bin/X11/X :0 -boards 0 -devdir /dev/input [default options]
:1 secure /usr/bin/X11/X :1 -boards 1,2 -devdir /dev/input1 [default options]
```

**Note:** For more information on `-boards` and `-devdir`, see the *Xsgi(1)* reference page from IRIX 5.2 for TKO. For more information on graphics pipe numbers, run */usr/gfx/gfxinfo*.

## 2.11 Testing the New Installation

*hinv* does not report the presence of TKO. To test the newly installed TKO, check the operation of each keyboard/monitor pair.

