

**POWER Channel™ E-Plex™
Installation Instructions**

Document Number 108-0114-001

Contributors

Written by Kameran Kashani

Illustrated by Dan Young

Edited by Cindy Kleinfeld, Christina Cary

Production by Lorrie Williams

Engineering contributions by John Carlson, Ty Swanson, Dean Olson, Carlin Otto

© Copyright 1995, Silicon Graphics, Inc.— All Rights Reserved

This document contains proprietary and confidential information of Silicon Graphics, Inc. The contents of this document may not be disclosed to third parties, copied, or duplicated in any form, in whole or in part, without the prior written permission of Silicon Graphics, Inc.

Restricted Rights Legend

Use, duplication, or disclosure of the technical data contained in this document by the Government is subject to restrictions as set forth in subdivision (c) (1) (ii) of the Rights in Technical Data and Computer Software clause at DFARS 52.227-7013 and/or in similar or successor clauses in the FAR, or in the DOD or NASA FAR Supplement. Unpublished rights reserved under the Copyright Laws of the United States. Contractor/manufacturer is Silicon Graphics, Inc., 2011 N. Shoreline Blvd., Mountain View, CA 94043-1389.

FCC Warning

This equipment has been tested and found compliant with the limits for a Class A digital device, pursuant to Part 15 of the FCC rules. These limits are designed to provide reasonable protection against harmful interference when the equipment is operated in a commercial environment. This equipment generates, uses, and can radiate radio frequency energy and, if not installed and used in accordance with the instruction manual, may cause harmful interference to radio communications. Operation of this equipment in a residential area is likely to cause harmful interference in which case the user will be required to correct the interference at his own expense.

Attention

This product requires the use of external shielded cables in order to maintain compliance pursuant to Part 15 of the FCC Rules.

**POWER Channel E-Plex Installation Instructions
Document Number 108-0114-001**

**Silicon Graphics, Inc.
Mountain View, California**

Silicon Graphics and IRIS are registered trademarks and CHALLENGE, DANG, GIOBus, POWER Channel, and Onyx are trademarks of Silicon Graphics, Inc. SONIC is a trademark of National Semiconductor Corporation.

Contents

Introduction	ix
1. E-Plex Overview and Theory of Operation	1-1
1.1 Overview of the E-Plex Board.....	1-1
1.1.1 Description and Layout of Board Components.....	1-2
1.1.2 I/O Housing and Filter-Board Assemblies	1-3
1.1.3 Connector Cables	1-5
1.2 Supported Systems and Configurations.....	1-5
2 Installing the E-Plex Board	2-1
2.1 Preparing for Installation.....	2-2
2.1.1 Checking the E-Plex Package for Completeness	2-2
2.1.2 Preparing the System.....	2-3
2.2 Installing Software	2-3
2.3 Where to Go Next	2-4
2.4 Installing on Challenge and Onyx L Deskside Systems.....	2-5
2.4.1 Shutting Down the System and Opening the I/O Door	2-5
2.4.2 Selecting a Mezzanine Slot	2-5
2.4.3 Installing the E-Plex Board	2-7
2.4.4 Completing the Installation.....	2-11
2.5 Installing on Challenge and Onyx XL Rackmount Systems.....	2-12
2.5.1 Shutting Down the System and Opening the I/O Door ..	2-12
2.5.2 Selecting a Mezzanine Slot	2-12
2.5.3 Installing the E-Plex Board	2-14
2.5.4 Completing the Installation.....	2-18
3 E-Plex LEDs and Error Codes	3-1
3.1 Summary of E-Plex LEDs.....	3-1
3.2 Master Board Fault LED	3-2
3.3 SONIC Chip Status LEDs.....	3-3
3.4 E-Plex Error Messages.....	3-3

Figures

Figure 1-1	E-Plex Hardware Components	1-1
Figure 1-2	E-Plex Board Component Layout	1-2
Figure 1-3	I/O and Filter-Board Assemblies (Upper and Lower)	1-4
Figure 1-4	Parts of the Connector Cables	1-5
Figure 2-1	Upper and Lower Mezzanine Slots on IO4 Boards.....	2-6
Figure 2-2	Installing the E-Plex Board on an IO4 Board	2-8
Figure 2-3	Installed E-Plex Board and I/O Housing in a Deskside System.....	2-10
Figure 2-4	Upper and Lower Mezzanine Slots on IO4 Boards.....	2-13
Figure 2-5	Installing the E-Plex Board on an IO4 Board	2-15
Figure 2-6	Installed E-Plex Board and I/O Housing in a Rackmount System .	2-17
Figure 3-1	Location of E-Plex LEDs.....	3-2

Tables

Table 1-1	Major E-Plex Board Components	1-3
Table 2-1	E-Plex Package Contents.....	2-2

Introduction

The POWER Channel™ E-Plex board is a short mezzanine card that provides eight 10-Base-T Ethernet connections. It can be installed in a short mezzanine slot on IO4 boards in all CHALLENGE and Onyx™ deskside (L) and rackmount (XL) systems.

The E-Plex hardware must be installed by a Silicon Graphics® system support engineer (SSE) or other personnel trained by Silicon Graphics in installation procedures. This document, *POWER Channel E-Plex Installation Instructions*, is provided to each SSE and contains complete details for hardware installation.

Installation and configuration of the E-Plex software can be done by customers or SSEs. The *POWER Channel E-Plex Software Configuration Guide* (shipped with each E-Plex board) provides software configuration details. Check any CD-ROMs included with the E-Plex board for Release Notes or other information about required software. See Also, the following document provide general information on installing software on Silicon Graphics systems:

- *Software Installation Administrator's Guide* (IRIX 5.3 and IRIX 6.1 systems)

Chapter 1

E-Plex Overview and Theory of Operation

This chapter provides an overview of the E-Plex board and describes various technical details of the board, including the main components and their functions.

1.1 Overview of the E-Plex Board

The E-Plex board is an intelligent 8-port Ethernet controller. Figure 1-1 shows the basic E-Plex hardware.

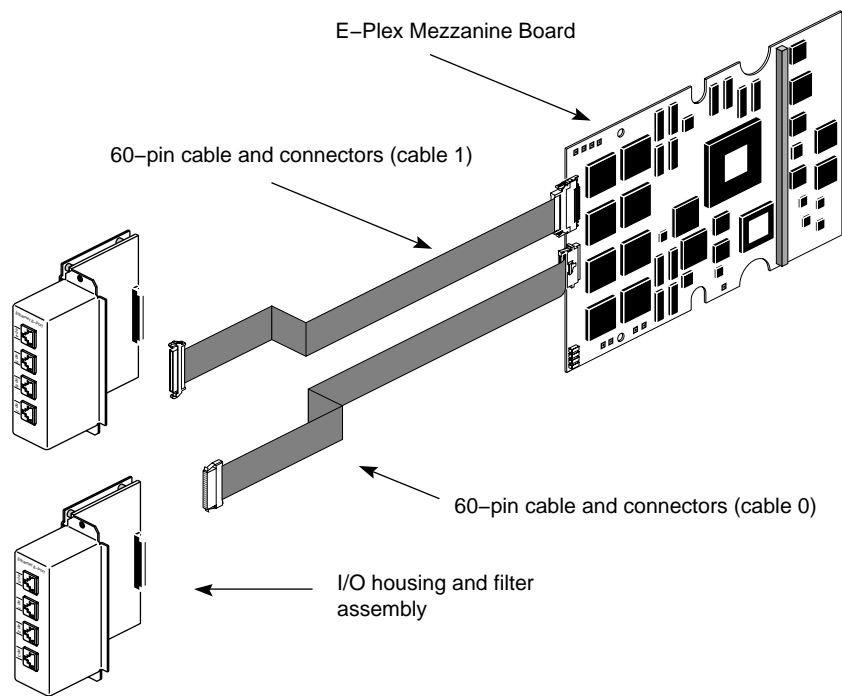

Figure 1-1 E-Plex Hardware Components

1.1.1 Description and Layout of Board Components

Figure 1-2 shows the layout of the E-Plex board's components.

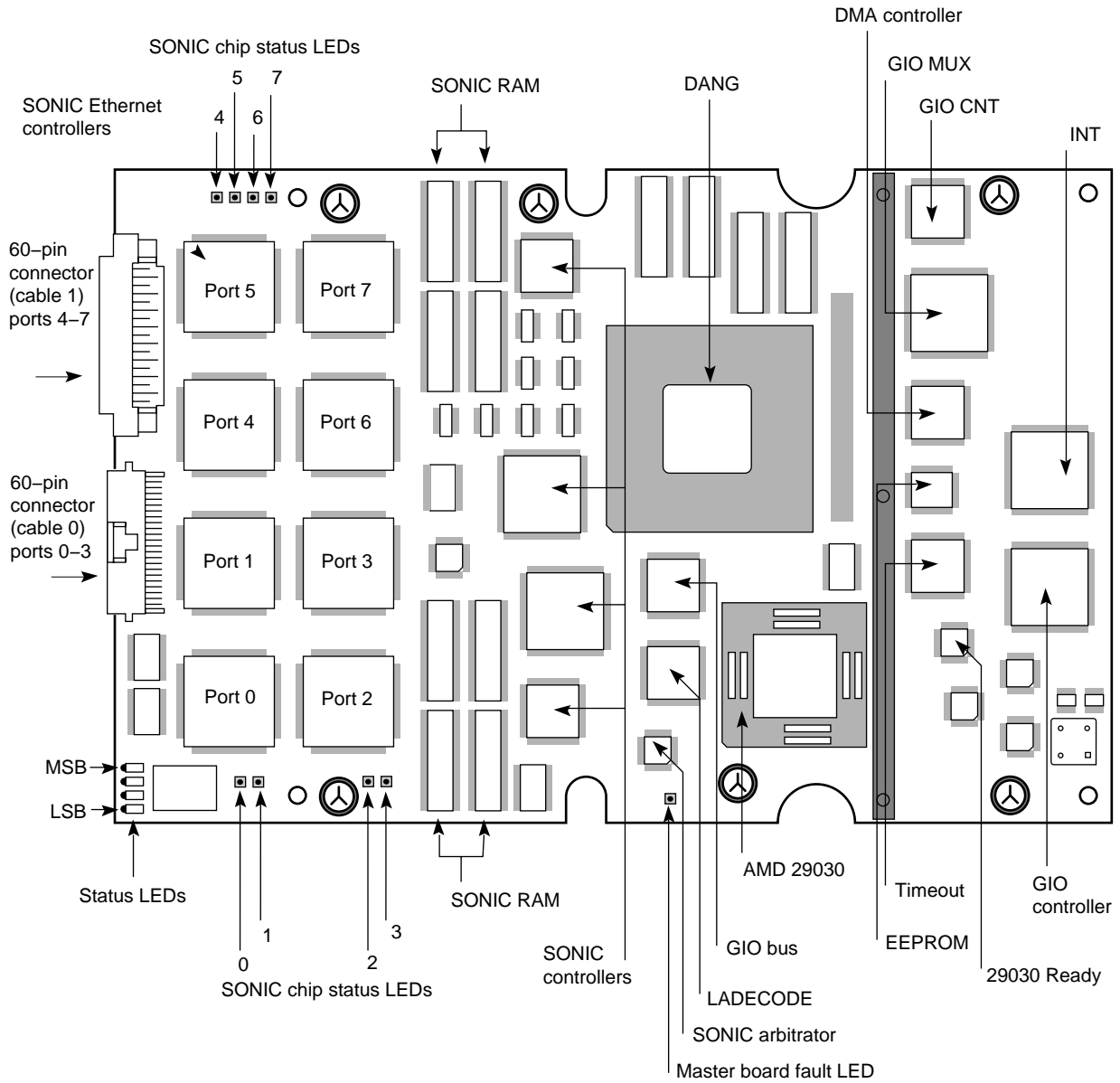

Figure 1-2 E-Plex Board Component Layout

The major components of the E-Plex board are described in Table 1-1.

Table 1-1 Major E-Plex Board Components

Component	Function
AMD 29030	Advanced Micro Devices 29030 microprocessor.
SONIC™	SONIC intelligent Ethernet controllers; one per channel, eight total chips on a single E-Plex board.
SONIC arbitrator	Arbitrates which SONIC chip communicates with the SONIC memory at a given time.
SONIC RAM	Memory for use by the SONIC chips.
DANG™	Proprietary Silicon Graphics ASIC that interfaces the GIOBus™ to the system.
EEPROM	PROM containing boot-up software, operating programs, and diagnostic programs for the E-Plex board.
Master board LED	Indicates the status of the AMD 29030 microprocessor; if the board status light is on steady, the microprocessor is halted and the board is not functioning properly.
Status LEDs	Used for factory service and testing.
SONIC chip status LEDs	Indicate the status of the ports controlled by the individual SONIC Ethernet controller chips; blinking green indicates transmit and receive activity; a light that is on solid yellow (or solid red on early version of the board) indicates that the port is not enabled. Note that during periods of intense network activity, the LEDs may blink green so rapidly as to appear to be lit solid.

1.1.2 I/O Housing and Filter-Board Assemblies

Two assemblies, which combine an I/O housing and filtering circuitry, are used with the E-Plex board. These are called the *upper* and *lower I/O housing and filter-board assemblies*. The lower assembly provides 10-Base-T connectors for the first four Ethernet ports, which are labeled **ep0** through **ep3**. The upper assembly provides the second four 10-Base-T connectors, which are labeled **ep4** through **ep7**. Figure 1-3 shows front and rear views of the two I/O and filter-board assemblies that are used with each E-Plex board.

Upper I/O housing and filter-board assembly (ep4 through ep7)

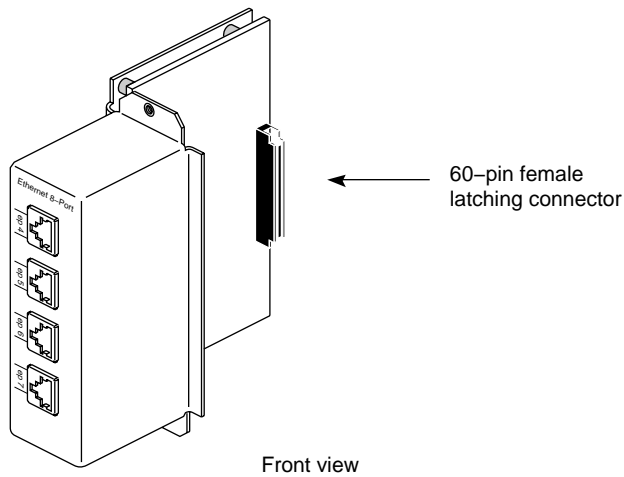

Lower I/O housing and filter-board assembly (ep0 through ep3)

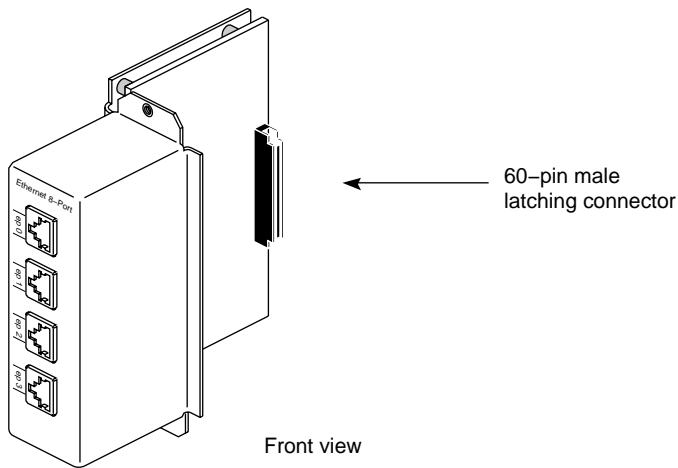

Figure 1-3 I/O and Filter-Board Assemblies (Upper and Lower)

The connector on the rear of each I/O and filter-board assembly is keyed so that it is impossible to attach the connector cables improperly. The connector cables are described in the next section.

1.1.3 Connector Cables

Two cables connect the E-Plex board to the two I/O and filter-board assemblies. These are designated *cable 0* and *cable 1*. Cable 0 connects to ports ep0 through ep3 and cable 1 connects to ports ep4 through ep7. Figure 1-4 shows these cables.

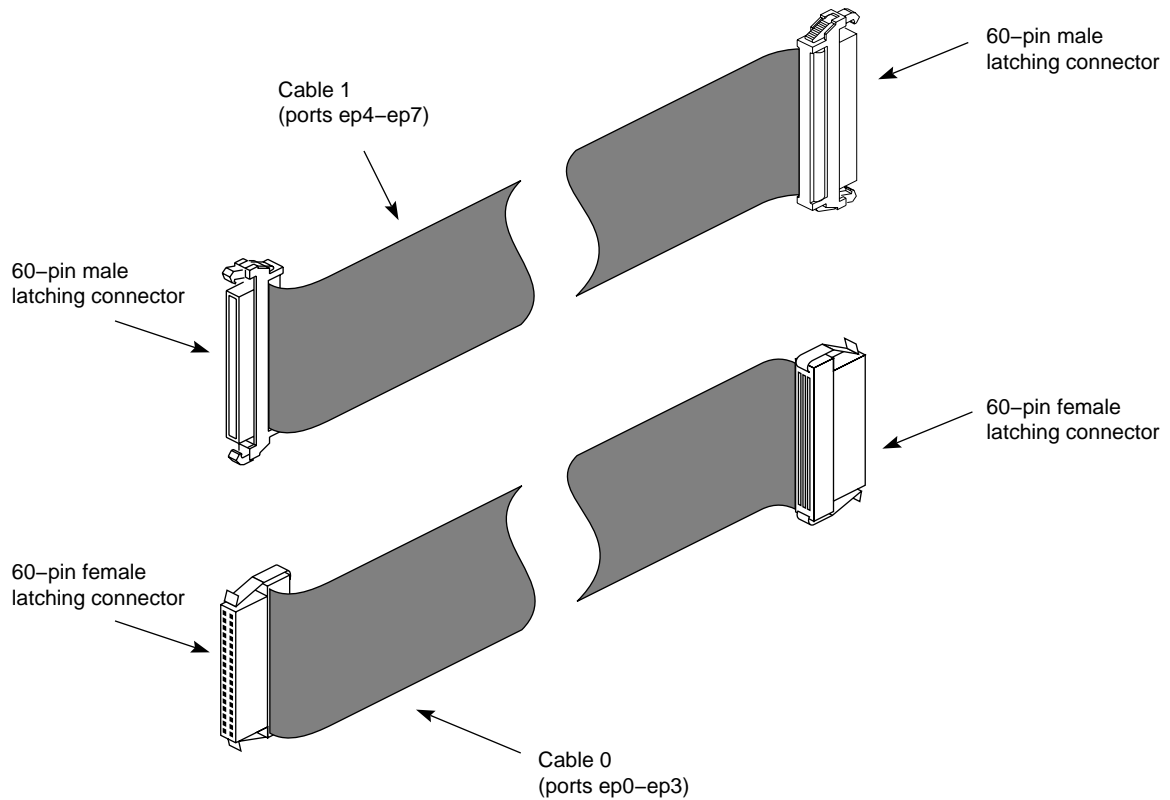

Figure 1-4 Parts of the Connector Cables

The connectors on each of the cables are keyed so that they cannot be attached to the incorrect I/O and filter-board assemblies.

1.2 Supported Systems and Configurations

A maximum of two E-Plex boards can be installed in CHALLENGE, POWER CHALLENGE, Onyx, and POWER Onyx deskside (L) and rackmount (XL) systems.

Installing the E-Plex Board

This chapter describes how to install the E-Plex mezzanine board, cables, and connectors into a Challenge or Onyx server or supercomputer. There is a separate section for each of the following platforms:

- Challenge, POWER Challenge, Onyx, and POWER Onyx L Deskside
- Challenge, POWER Challenge, Onyx, and POWER Onyx XL Rackmount



Warning: Installing this equipment requires specific training and technical knowledge. These instructions are provided for use only by Silicon Graphics system support engineers (SSEs) or other personnel trained by Silicon Graphics. This equipment uses internal electrical power that is hazardous if the equipment is improperly handled.

2.1 Preparing for Installation

Before starting the installation, prepare yourself and the equipment by following the instructions below.

2.1.1 Checking the E-Plex Package for Completeness

Verify that the E-Plex package is complete. It should contain the items listed in Table 2-1.

Table 2-1 E-Plex Package Contents

Item	Quantity	Part Number
E-Plex board	1	034-0590-006
60-pin to 60-pin cable, ports 0 through 3	1	018-0493-001
60-pin to 60-pin cable, ports 4 through 7	1	018-0494-001
I/O housing and filter-board plate) assembly ports 0 through 3	1	013-1255-001

Table 2-1 E-Plex Package Contents

Item	Quantity	Part Number
I/O housing and filter-board plate) assembly ports 4 through 7	1	013-1256-001
Screws for attaching E-Plex board to IO4 board standoffs	4	
Screws for attaching E-Plex board to IO4 board standoffs	4	
Label: Connector IDs	1 or 2 sheets	024-0854-002
Label Cable wrap IDs	1 or 2 sheets	024-0855-002
CD-ROMs with software (including online release notes and other information)	2	
<i>POWER Channel E-Plex Installation Instructions</i>	1 manual	108-0114-001
<i>POWER Channel E-Plex Software Configuration Guide</i>	1 manual	007-2414-001

If any of these components are missing, do not proceed with the installation. Notify the customer or the customer's sales representative.

Note: The part numbers listed above reflect the E-Plex product when this manual went to press. The part numbers may have been revised since that time.

2.1.2 Preparing the System

Follow the instructions in this section to prepare the system for installation.

Caution: This equipment is extremely sensitive and susceptible to damage by electrostatic discharge (ESD), a spark caused by the build-up of electrical static potential on clothing and other material. You must use proper ESD preventive measures as explained in the "Safety" section of the *CHALLENGE/Onyx Deskside Installation Instructions* and the *CHALLENGE/Onyx Rackmount Installation Instructions*.

1. At a shell prompt, use the *versions* command to verify that the version of the IRIX operating system is correct for this E-Plex release:

```
% versions eoel
I eoel date Execution Only Environment 1, version
```

The E-Plex board is supported in IRIX 5.3 and IRIX 6.1 and later.

2. Verify that any crucial filesystems are backed up.

2.2 Installing Software

Certain software patches may be required to make the board fully functional and to fix potential problems. The CD-ROMs included with the board contain the appropriate software patches.

To install the software patches, follow these steps:

1. If a CD-ROM drive is not already attached to the system, do so now.
2. Insert the appropriate CD-ROM for the particular version of IRIX (either the 5.3 CD or the 6.1 CD) into the CD-ROM drive.
3. At a shell prompt, enter this command:

```
more /CDROM/README_FIRST.txt
```

The file *README_FIRST.txt* contains up-to-the-minute information on which patches to apply to various Challenge and Onyx systems and various releases of IRIX. It also contains instructions for installing the patches.

4. Follow the instructions in the file *README_FIRST.txt* to install any required patches from the CD.
5. When you are finished installing patches from the CD-ROM, eject it from the drive.

You are now ready to shut down the system and begin installing the E-Plex board. See Section 2.3, “Where to Go Next.”

For complete information on configuring the system for use with the E-plex board, see the *POWER Channel E-Plex Software Configuration Guide*.

2.3 Where to Go Next

To install the E-Plex board in a deskside system (Challenge L, POWER Challenge L, Onyx L, or POWER Onyx L), go to Section 2.4, “Installing on Challenge and Onyx L Deskside Systems.”

To install the E-Plex board in a rackmount system (Challenge XL, POWER Challenge XL, Onyx XL, or POWER Onyx XL), go to Section 2.5, “Installing on Challenge and Onyx XL Rackmount Systems.”

2.4 Installing on Challenge and Onyx L Deskside Systems

This section describes the steps for installing the E-Plex board into a Challenge, POWER Challenge, Onyx, or POWER Onyx L deskside system.



Warning: Installing this equipment requires specific training and technical knowledge. These instructions are provided for use only by Silicon Graphics system support engineers (SSEs) or other personnel trained by Silicon Graphics. This equipment uses internal electrical power that is hazardous if the equipment is improperly handled.

2.4.1 Shutting Down the System and Opening the I/O Door

Before shutting down the system, follow the appropriate procedures for notifying any users who are logged in, and for halting the IRIX operating system gracefully. Refer to the *IRIX Advanced Site and Server Administration Guide* for complete details.

Once the operating system has halted, follow these steps to turn off the system and open the I/O panel:

1. Shut off the system by turning the key on the System Controller panel (located at the front) to **OFF**. When the system is off, switch the circuit breaker on the back to **OFF**. Wait at least one minute for power to drain from the offline switchers (OLSs) before proceeding.



Warning: Failure to turn off the circuit breaker and wait for the OLSs to drain power may result in electrical shock. Failure to wait for the system to shut down before proceeding with board installation may cause irreparable damage to system components or data.

2. Open the front door and pull down the I/O panel in the front of the chassis to expose the IO4 boards.
3. Remove the board locks.

You are now ready to examine the available IO4 boards and locate an open mezzanine slot.

2.4.2 Selecting a Mezzanine Slot

To install the E-Plex board, locate an available short mezzanine slot on an IO4 board. When selecting a mezzanine slot, use the following guidelines:

- If the system has only one IO4 board, this is the location for the E-Plex board. Although the E-Plex board may be installed in either the upper or lower position on the IO4 board, it is strongly recommended that you install it in the lower slot first, if that slot is available. See Figure 2-1.

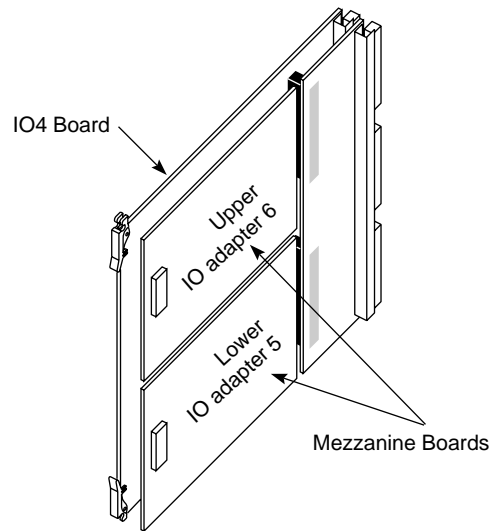

Figure 2-1 Upper and Lower Mezzanine Slots on IO4 Boards

- If you have a choice of IO4 boards that have open mezzanine slots, keep in mind the potential problems described below:
 - When the system boots it automatically configures the network interfaces for the E-Plex boards based on their position on the IO4 boards (see Figure 2-1) and on the position of the IO4 boards in the system chassis. The system examines all of the boards at boot time, starting with the main IO4 (slot 5 in Challenge L and slot 3 in the Onyx deskside) and proceeding down the available slots. For the Challenge, this means slot 5, slot 4, slot 3, and slot 2 in that order. There is only one IO4 board in the Onyx deskside.
 - On each IO4, IO adapter 5 (lower location) is examined first, then IO adapter 6 (upper location.)
 - The closer any board is placed to IO adapter position 5 on the main IO4 board, the further it is said to be *upstream*. The farther away from that position it is installed, the farther it is said to be *downstream*.
 - If there are two E-Plex boards installed in the system, the one that is furthest upstream is recognized and configured first.
 - Install the first E-Plex board as far upstream as possible, especially if you are installing only one E-Plex board at this time. It will be extremely inconvenient if you later install another E-Plex board upstream of the first board, because when the system boots it will automatically reconfigure the network interfaces for the first board. This will force you to either switch network cables between the two

boards or change the network configuration (which potentially involves editing nine or ten files.) It is better to avoid these problems by installing the first E-Plex board as far upstream as possible.

- For a complete description of the difference between upstream and downstream boards and how their positions affect the way that their network interfaces are configured by IRIX, and how to reconfigure the network interface, see the *POWER Channel E-Plex Software Configuration Guide*.
- If there are no unoccupied mezzanine slots, you must install another IO4 board. Contact the sales representative to order one. The installation cannot be continued until a mezzanine slot is available.
Note: You can install a maximum of four IO4 boards in a Challenge L, and a maximum of one IO4 board in an Onyx deskside system. If the maximum number of IO4 boards are already installed, and if all the mezzanine slots are occupied, an E-Plex board cannot be installed in the system.

2.4.3 Installing the E-Plex Board

Follow the steps below to install the E-Plex mezzanine board.

1. Remove the IO4 board that you have selected from the deskside chassis.
2. Lay the board on a flat antistatic surface so that the component side faces up and the SCSI connectors face toward you, as illustrated in Figure 2-2.
3. Locate the selected mezzanine slot (upper or lower), as illustrated in Figure 2-2.

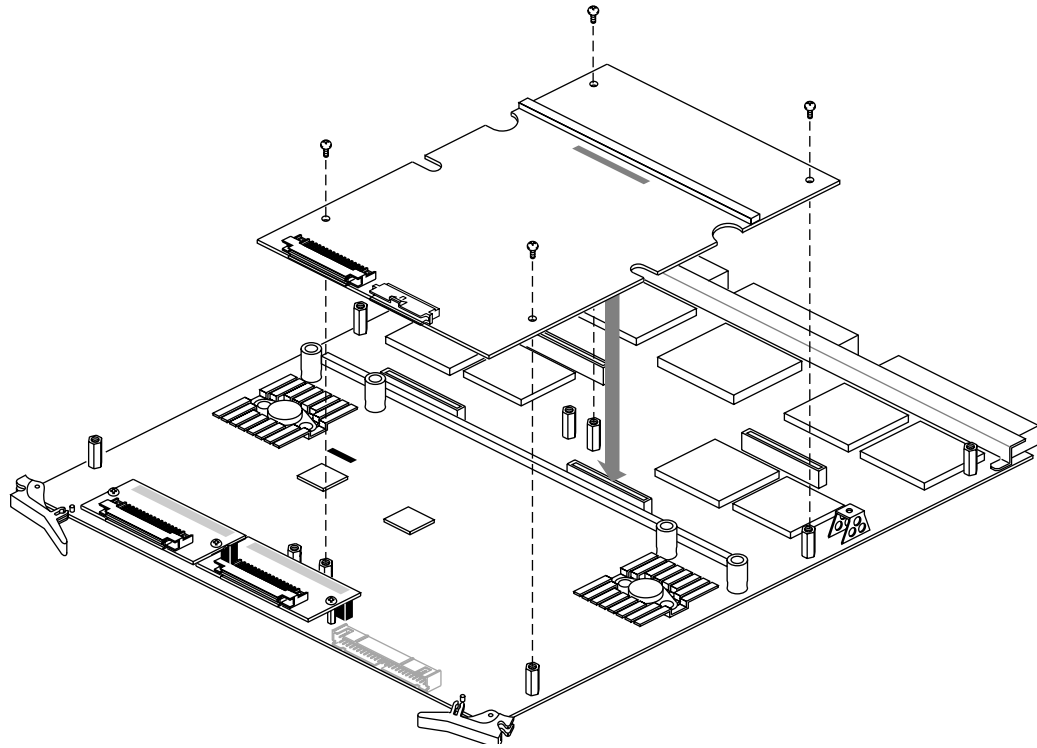

Figure 2-2 Installing the E-Plex Board on an IO4 Board

4. Position the E-Plex board onto the selected slot so that the connector on the bottom of the card matches the mezzanine board receptacle on the IO4 board and the standoffs match the card's holes. Figure 2-2 illustrates the correct positioning for the lower slots.
5. Install the screws shipped with the E-Plex board. The IO4 board standoffs have a "float" feature, so the screws do not tighten completely.
6. Label the E-Plex cables (cable 0 and cable 1). Use the appropriate labels from the E-Plex cablewrap label sheet.
7. If there is already an E-Plex board installed in the system, and you are installing an additional E-Plex, you should relabel the upper and lower I/O housing. (The default labels applied at the factory are for the first E-Plex board in the system.)

From the sheet of labels, remove the ones with the identification for a second E-Plex board (**ep10** through **ep13**, and **ep14** through **ep17**). Apply these on the appropriate I/O housing. The label with **ep10** through **ep13** should cover **ep0** through **ep3**, and the label with **ep14** through **ep17** should cover **ep4** through **ep7**.

8. Reinstall the IO4 board into the chassis, as illustrated in Figure 2-3. Push the board firmly into the backplane. If the IO4 has a VCAM or GCAM board, these boards must also connect to the backplane.
9. Locate the upper I/O housing and filter assembly (which has ports **ep4** through **ep7**) and its connector cable (cable 1).

10. Attach cable 1 (which has a 60-pin male connector) to the upper I/O housing and filter assembly.
11. Attach cable 0 (which has a 60-pin female connector) to the lower I/O housing and filter assembly.
12. Remove two blank panel plates from the system's I/O panel and install the E-Plex I/O housings.

Note: Because of the depth of the I/O housing and filter assembly, we recommend that you install the assemblies in the upper row of I/O panel openings in Deskside systems (as shown in Figure 2-3). If one of the I/O housings and filter assemblies is installed in the bottom row of the I/O panel, you may not be able to install or remove a board in the slot directly behind that E-Plex I/O housing unless you remove the housing first.

13. Attach cables 0 and 1 to the appropriate connectors on the E-Plex board. The connectors are keyed so that it is impossible to install them incorrectly.
14. Close the I/O door(s) and the chassis doors.
15. Attach any Ethernet cables, as required.
 - Make sure the network address used on each cable is correct for the port, as configured in the software configuration files. (See the *POWER Channel E-Plex Software Configuration Guide*.)

The hardware installation is complete. The finished installation should look similar to Figure 2-3.

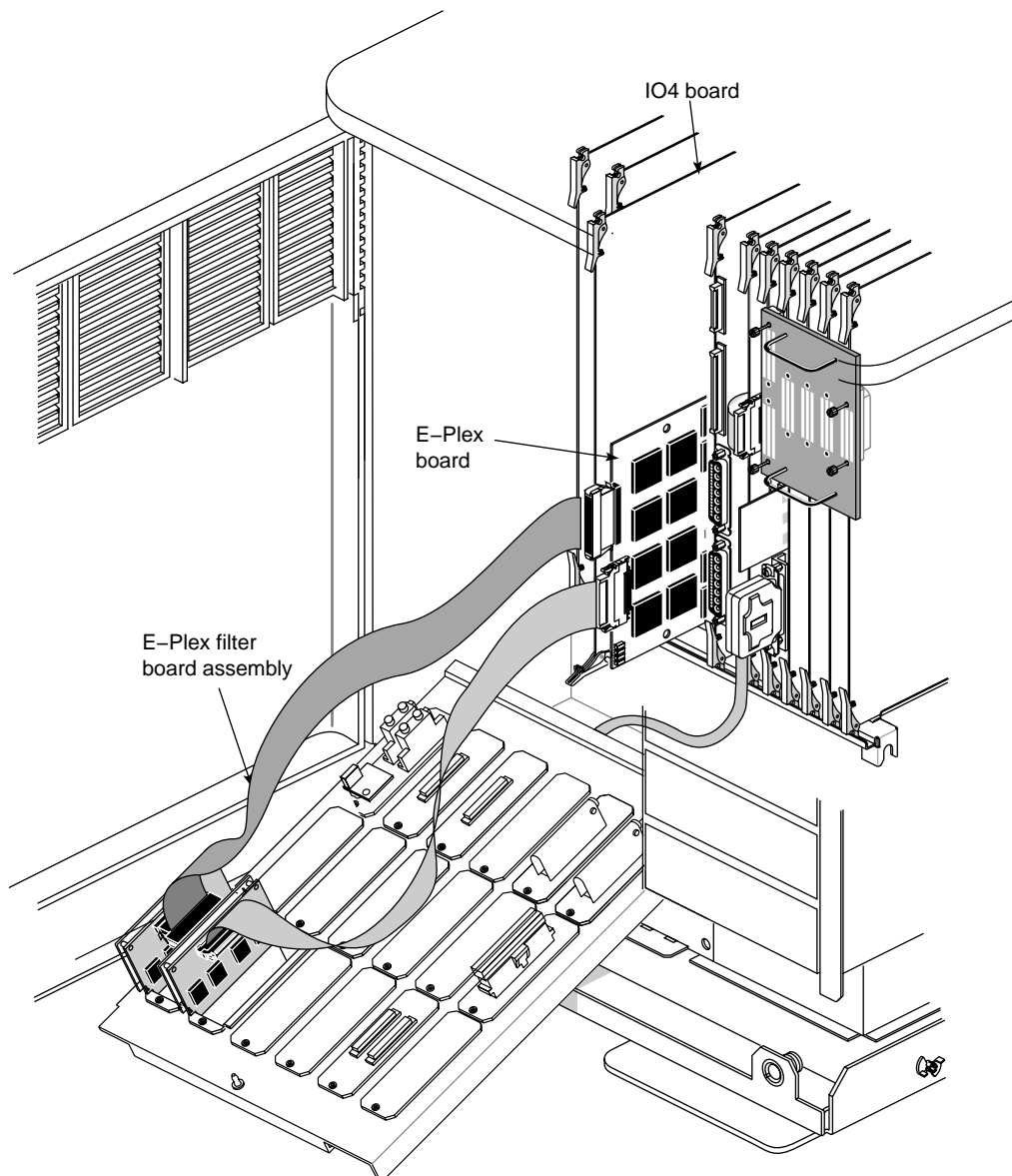

Figure 2-3 Installed E-Plex Board and I/O Housing in a Deskside System

2.4.4 print/internal.cables.ai 90% **Completing the Installation**

To finish the installation, follow these steps:

1. Switch the circuit breaker on the back of the chassis to **ON**, then turn the key switch on the front to **ON**.
 - You should eventually see the System Maintenance Menu. Select option 1 to start the system.

As the system boots, you should see some messages about the kernel being automatically rebuilt.

Note: If you do not see these messages, it means you have not installed the E-Plex software.

2. When the system has completed booting, log in as root.
 - If you have not done so already, use either *inst* or *swmgr* to install the E-Plex software. See Section 2.2, “Installing Software.” After installing the E-Plex software, reboot the system using the *reboot* command.
3. Once the E-Plex software is installed, make sure the board is recognized by the system using the *hinv* command:

```
% /sbin/hinv
. . .
I/O board, Ebus slot#: IO4 revision x
. . .
E-Plex Ethernet controller: ep0-7, slot 3, adapter 5, firmware 9503202300
. . .
```

This example shows a single E-Plex board installed in slot 3, adapter position 5.

Note: If the board is not listed, reinstall the product (both boards and all cables), making sure everything is firmly seated and tightly connected.

You are finished installing the E-Plex board.

If you have not done so already, turn to the *POWER Channel E-Plex Software Configuration Guide* to configure the network interfaces.

2.5 Installing on Challenge and Onyx XL Rackmount Systems

This section describes the steps for installing the E-Plex board into a Challenge, POWER Challenge, Onyx, or POWER Onyx XL Rackmount system.



Warning: Installing this equipment requires specific training and technical knowledge. These instructions are provided for use only by Silicon Graphics system support engineers (SSEs) or other personnel trained by Silicon Graphics. This equipment uses internal electrical power that is hazardous if the equipment is improperly handled.

2.5.1 Shutting Down the System and Opening the I/O Door

Before shutting down the system, follow the appropriate procedures for notifying any users who are logged in, and for halting the IRIX operating system gracefully. Refer to the *IRIX Advanced Site and Server Administration Guide* for complete details.

Once the operating system has halted, follow these steps to turn off the system and open the I/O panel:

1. Shut off the system by turning the key on the System Controller panel (located at the front) to **OFF**. When the system is off, switch the circuit breaker on the back to **OFF**. Wait at least one minute for power to drain from the offline switchers (OLSs) before proceeding.



Warning: Failure to turn off the circuit breaker and wait for the OLSs to drain power may result in electrical shock. Failure to wait for the system to shut down may cause irreparable damage to system components or data.

2. Open the front door and pull down the I/O panel in the front of the chassis to expose the IO4 boards.
3. Remove the board locks.

You are now ready to examine the available IO4 boards and locate an open mezzanine slot.

2.5.2 Selecting a Mezzanine Slot

To install the E-Plex board, you need to locate an available short mezzanine slot on an IO4 board. When selecting a mezzanine slot, use the following guidelines:

- If the system has only one IO4 board, this is the location for the E-Plex board. Although the E-Plex board may be installed in either the upper or lower position on the IO4 board, it is strongly recommended that you install it in the lower slot first, if that slot is available. See Figure 2-4.

[figs/io4.with.2shmezz.ai](#) 100%

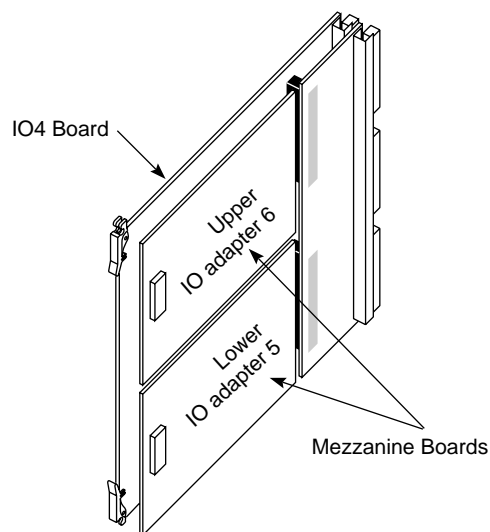

Figure 2-4 Upper and Lower Mezzanine Slots on IO4 Boards

- If you have a choice of IO4 boards that have open mezzanine slots, keep in mind the potential problems described below:

- When the system boots it automatically configures the network interfaces for the E-Plex boards based on their position on the IO4 boards (see Figure 2-4) and on the position of the IO4 boards in the system chassis. The system examines all of the boards at boot time, starting with slot 15 (Challenge) or slot 11 (Onyx), and proceeding down the available slots.
- On each IO4, IO adapter 5 (lower location) is examined first, then IO adapter 6 (upper location.)
- The closer a board is placed to IO adapter location 5 on the main IO4 board, the further it is said to be *upstream*. The farther away from that location it is installed, the farther it is said to be *downstream*.
- If there are two E-Plex boards installed in the system, the one that is furthest upstream is recognized and configured first.
- Install the first E-Plex board as far upstream as possible, especially if you are installing only one E-Plex board at this time. It will be extremely inconvenient if you later install another E-Plex board upstream of the first board, because when the system boots it will automatically reconfigure the network interfaces for the first board. This will force you to either switch network cables between the two boards or change the network configuration (which potentially involves editing nine or ten files.) It is better to avoid these problems by installing the first E-Plex board as far upstream as possible.
- For a complete description of the difference between upstream and downstream boards and how their positions affect the way that their network interfaces are configured by IRIX, and how to reconfigure the network interface, see the *POWER Channel E-Plex Software Configuration Guide*.
- If there are no unoccupied mezzanine slots, you must install another IO4 board. Contact the sales representative to order one. The installation cannot be continued until a mezzanine slot is available.
 - Note:** You can install a maximum of six IO4 boards in a Challenge XL, and a maximum of four IO4 boards in an Onyx rackmount. If all IO4 boards are already installed, and if all the mezzanine slots are occupied, an E-Plex board cannot be installed in this system.

2.5.3 Installing the E-Plex Board

Follow the steps below to install the E-Plex mezzanine board.

1. Remove the IO4 board that you have selected from the rackmount chassis.
2. Lay the board on a flat antistatic surface so that the component side faces up and the SCSI connectors face toward you, as illustrated in Figure 2-5
3. Locate the selected mezzanine slot, as illustrated in Figure 2-5.

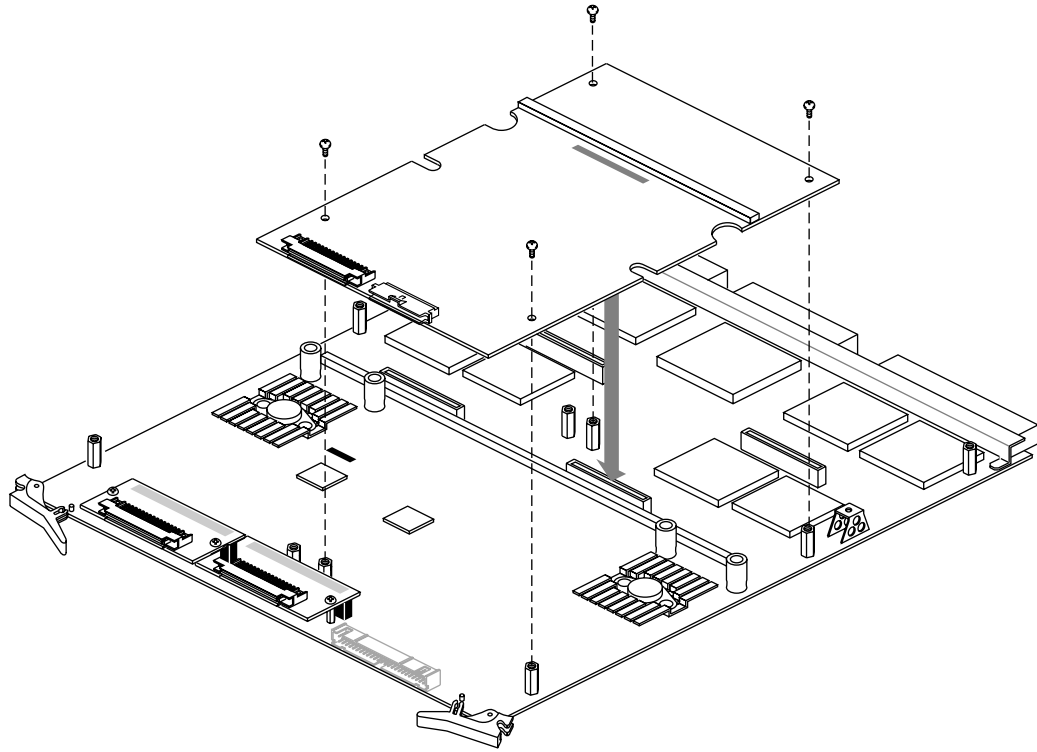

Figure 2-5 Installing the E-Plex Board on an IO4 Board

4. Position the E-Plex board onto the selected slot so that the connector on the bottom of the card matches the mezzanine board receptacle on the IO4 board and the standoffs match the card's holes. Figure 2-5 illustrates the correct positioning for the lower slot on an IO4.
5. Install the screws shipped with the E-Plex board. The IO4 board standoffs have a "float" feature, so the screws do not tighten completely.
6. Label the E-Plex cables (cable 0 and cable 1). Use the appropriate labels from the E-Plex cablewrap label sheet.
7. If there is already an E-Plex board installed in the system, and you are installing an additional E-Plex, you should relabel the upper and lower I/O housing. (The default labels applied at the factory are for the first E-Plex board in the system.)

From the sheet of labels, remove the ones with the identification for a second E-Plex board (**ep10** through **ep13**, and **ep14** through **ep17**). Apply these on the appropriate I/O housing. The label with **ep10** through **ep13** should cover **ep0** through **ep3**, and the label with **ep14** through **ep17** should cover **ep4** through **ep7**.

8. Reinstall the IO4 board into the chassis, as illustrated in Figure 2-6. Push the board firmly into the backplane. If the IO4 has a VCAM or GCAM board, these boards must also connect to the backplane.
9. Locate cable 1 and the upper I/O housing (which has ports **ep4** through **ep7**).

10. Attach cable 1 (which has a 60-pin male connector) to the upper I/O plate and filter assembly.
11. Locate cable 0 (which has a 60-pin female connector) and attach it to the lower I/O housing.
12. Remove two blank panel plates from the middle row of the system's I/O panel and install the E-Plex housings.

Note: Because of the size of the I/O housing and filter assembly, we recommend that you install the assemblies in the middle row of I/O panel openings on Rackmount systems (as shown in Figure 2-6). If the I/O housings and filter assemblies are installed in an upper row of the I/O panel, the filter assembly circuit boards can strike the upper edge of the cardcage opening and become damaged. If they are installed in the bottom row of the I/O panel, you may not be able to install or remove a board in the slot directly behind that E-Plex I/O housing unless you remove the housings first.

13. Attach cable 0 and cable 1 to the E-Plex board.
14. Close the I/O door(s) and the chassis doors.
15. Attach any Ethernet cables, as required.
 - Make sure the network address used on each cable is correct for the port, as configured in the software configuration files. (See the *POWER Channel E-Plex Software Configuration Guide*.)

The hardware installation is complete. Figure 2-6 shows the completed installation.

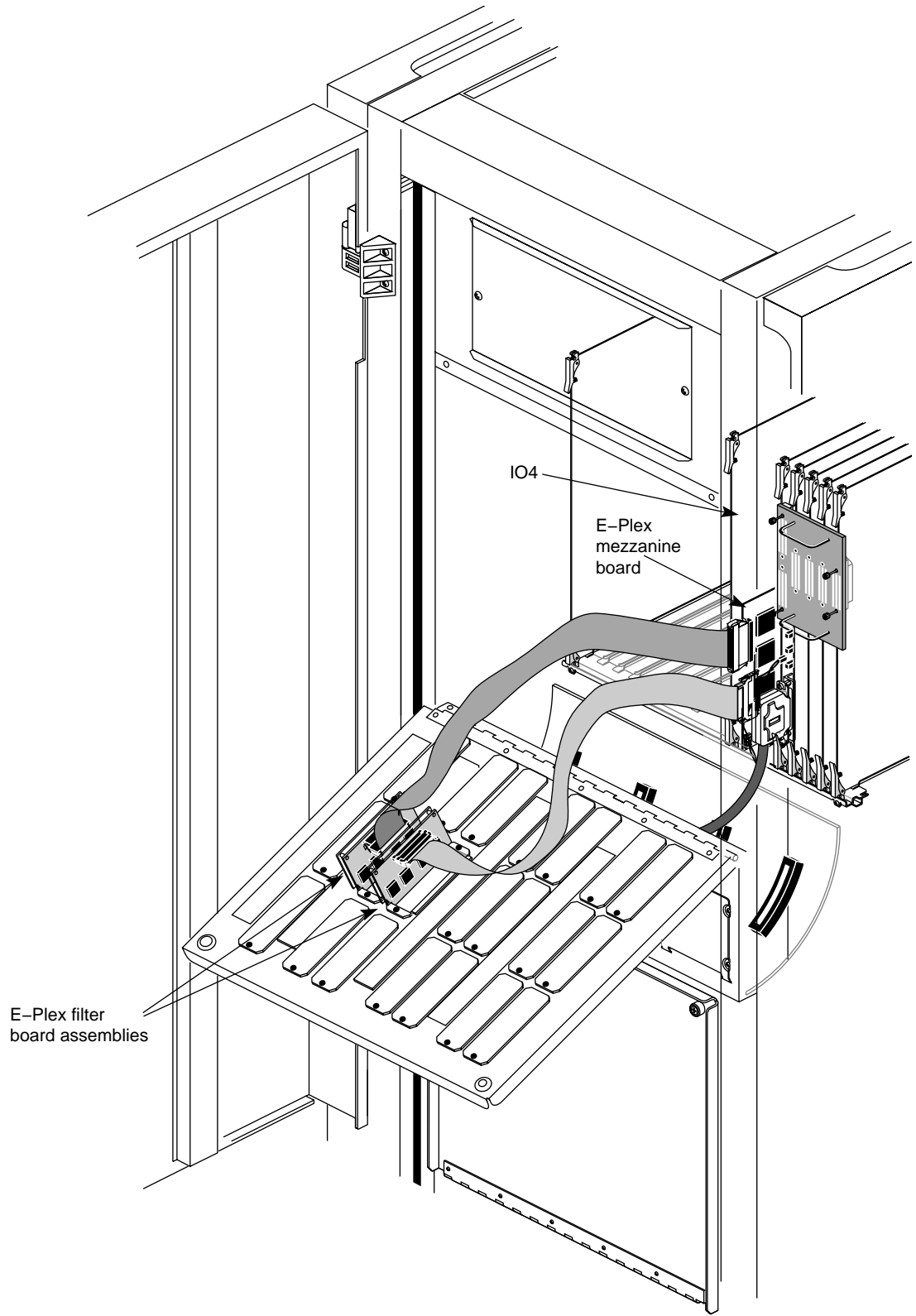

Figure 2-6 Installed E-Plex Board and I/O Housing in a Rackmount System

2.5.4 Completing the Installation

To finish the installation, follow these steps:

1. Switch the circuit breaker on the back of the chassis to **ON**, then turn the key switch on the front to **ON**.
 - You should eventually see the System Maintenance Menu. Select option 1 to start the system.

As the system boots, you should see some messages about the kernel being automatically rebuilt.

Note: If you do not see these messages, it means you have not installed the E-Plex software.

2. When the system has completed booting, log in as root.
 - If you have not done so already, use either *inst* or *swmgr* to install the E-Plex software. See Section 2.2, “Installing Software.” After installing the E-Plex software, reboot the system using the *reboot* command.
3. Once the E-Plex software is installed, make sure the board is recognized by the system using the *hinv* command:

```
% /sbin/hinv
. . .
I/O board, Ebus slot#: I04 revision x
. . .
E-Plex Ethernet controller: ep0-7, slot 3, adapter 5, firmware 9503202300
. . .
```

This example shows a single E-Plex board installed in slot 3, adapter position 5.

Note: If the board is not listed, reinstall the product (both boards and all cables), making sure everything is firmly seated and tightly connected.

You are finished installing the E-Plex board.

If you have not done so already, turn to the *POWER Channel E-Plex Software Configuration Guide* to configure the network interfaces.

Chapter 3

E-Plex LEDs and Error Codes

This chapter describes the light-emitting diodes (LEDs) found on the E-Plex board.

3.1 Summary of E-Plex LEDs

There are three types of LEDs on the E-Plex board:

- Master board fault LED; this indicates the status of the AMD 29030 CPU.
- SONIC chip status LEDs; these indicate the status of the individual SONIC Ethernet controllers.
- Status LEDs; these are used only for factory debugging.

Figure 3-1 shows the locations of LEDs on the E-Plex board.

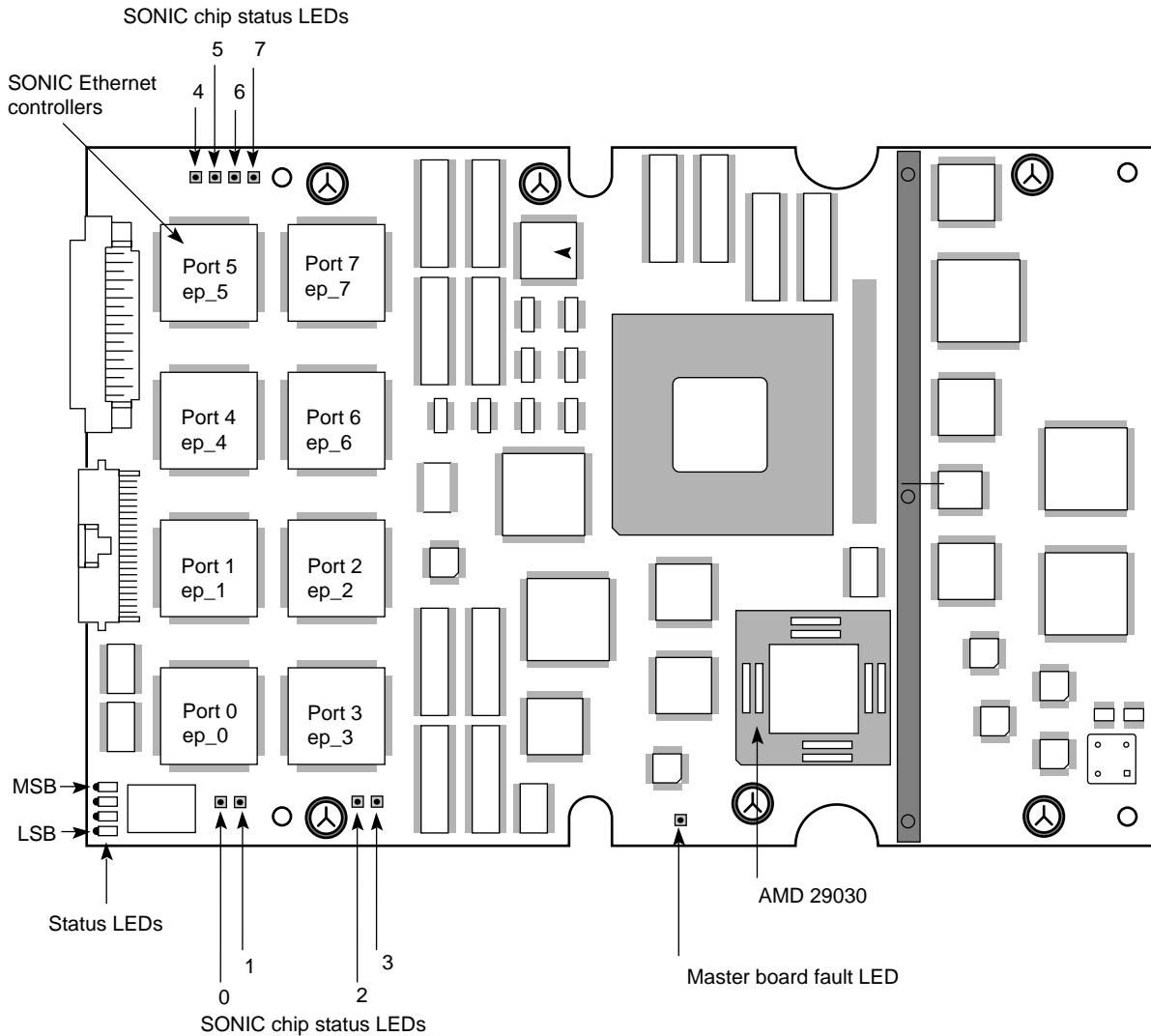

Figure 3-1 Location of E-Plex LEDs.

3.2 Master Board Fault LED

This LED indicates whether or not the AMD 29030 microprocessor is functioning. (See Figure 3-1.) When the LED is off (unlit), the microprocessor is functioning normally.

If the LED is lit for a long period of time, the AMD 29030 microprocessor has halted. This indicates a serious problem and the E-Plex board should be replaced. The LED may light briefly when the AMD 29030 microprocessor resets, but this will be a brief, almost undetectable pulse of light.

3.3 SONIC Chip Status LEDs

There is one SONIC chip status LED for each SONIC Ethernet controller. Figure 3-1 shows how the LEDs correspond to the individual chips and port numbers.

When an LED appears green, or is blinking rapidly, the port corresponding to that LED is transmitting and receiving data.

When an LED is solid yellow (or red on early E-Plex revisions), the port that corresponds to that LED is not enabled.

3.4 E-Plex Error Messages

E-Plex messages that appear on the system console and in the system error log file (*/var/adm/SYSLOG*) are described in the *POWER Channel E-Plex Software Configuration Guide*.

