

IRIS POWER Series R4400-150 (IP17) Upgrade Installation Instructions

Document Number 108-0105-001

Contributors

Written by Diana Hirsch, Robert Laws, and Pablo Rozal

Edited by Nan Schweiger

Illustrations by Dan Young

Production by Derrald Vogt

Engineering and other contributions by Mark Bailey, Linda Becerril, Donna McMaster, Reuel Nash, Bob Patel, and Tom Shou

© Copyright 1993, Silicon Graphics, Inc.— All Rights Reserved

This document contains proprietary and confidential information of Silicon Graphics, Inc. The contents of this document may not be disclosed to third parties, copied, or duplicated in any form, in whole or in part, without the prior written permission of Silicon Graphics, Inc.

Restricted Rights Legend

Use, duplication, or disclosure of the technical data contained in this document by the Government is subject to restrictions as set forth in subdivision (c) (1) (ii) of the Rights in Technical Data and Computer Software clause at DFARS 52.227-7013 and/or in similar or successor clauses in the FAR, or in the DOD or NASA FAR Supplement. Unpublished rights reserved under the Copyright Laws of the United States. Contractor/manufacturer is Silicon Graphics, Inc., 2011 N. Shoreline Blvd., Mountain View, CA 94039-7311.

FCC Warning

This equipment has been tested and found compliant with the limits for a Class A digital device, pursuant to Part 15 of the FCC rules. These limits are designed to provide reasonable protection against harmful interference when the equipment is operated in a commercial environment. This equipment generates, uses, and can radiate radio frequency energy and, if not installed and used in accordance with the instruction manual, may cause harmful interference to radio communications. Operation of this equipment in a residential area is likely to cause harmful interference, in which case the user will be required to correct the interference at his or her own expense.

Attention

This product requires the use of external shielded cables in order to maintain compliance pursuant to Part 15 of the FCC rules.

**IRIS POWER Series R4400-150 (IP17) Upgrade Installation Instructions
Document Number 108-0105-001**

**Silicon Graphics, Inc.
Mountain View, California**

Silicon Graphics and IRIS are registered trademarks and Elan, Extreme, IRIX, POWER Series, PowerVision, RealityEngine, and VGXT are trademarks of Silicon Graphics, Inc.

Contents

- 1. Introduction**1-1
 - 1.1 IP17 Features1-2
 - 1.2 IP17 Board Connectors and Indicators1-4

- 2. Kit Contents**2-1
 - 2.1 HU-4DCR75CPC Kit Contents2-1
 - 2.2 Safety2-2
 - 2.3 HU-4DCR75CPC Upgrade Steps2-3

- 3. Preparing the System**3-1
 - 3.1 Tools and Materials3-1
 - 3.2 General Chassis Preparation3-1
 - 3.3 Preparing a Twin Tower Chassis3-2
 - 3.4 Preparing a Rackmount Chassis3-4
 - 3.5 Preparing a Single Tower Chassis3-5

- 4. Configuring Memory**4-1
 - 4.1 Tools and Materials4-1
 - 4.2 Removing SIMMs4-1
 - 4.3 IP17 SIMM Configuration4-3
 - 4.3.1 SIMM Blocks and Banks4-3
 - 4.3.2 Allowable SIMM Combinations4-4
 - 4.3.3 High-density SIMM Configurations4-6
 - 4.3.4 Low-density SIMM Configurations4-7
 - 4.3.5 Mixed High- and Low-density SIMM Configurations4-8
 - 4.4 Installing SIMMs4-10

- 5. Installing the Board**5-1
 - 5.1 IP17 Jumper Verification5-1
 - 5.2 Board Location5-3
 - 5.3 Installing the New IP175-3
 - 5.4 Completing the Installation5-4

- 6. Verification and Testing6-1**
 - 6.1 Bringing Up the System6-1
 - 6.2 Testing the Board6-3
 - 6.3 Software Installation6-3
 - 6.4 Loading and Running Diagnostics6-4
 - 6.4.1 Installing the Diagnostics from 1/4-inch Tape or a CD-ROM6-4
 - 6.4.2 Diagnostic Commands6-4
 - 6.4.3 Running the IP17 Diagnostics6-6

- 7. Returning the Old IP17 Board7-1**
 - 7.1 Packing the Board7-1
 - 7.2 Labeling7-1
 - 7.3 North American Shipping Instructions7-2
 - 7.4 International Shipping Instructions7-2
 - 7.4.1 Shipping Documentation7-2
 - 7.4.2 SkyNet International Directory7-3

IndexIndex-1

Figures

- Figure 1-1** Block Diagram of IP17 Board1-3
- Figure 1-2** Connectors and Indicators1-4
- Figure 3-1** Removing the Wiring Harness from the Old IP17 Board in a R4000-50 Twin Tower3-2
- Figure 3-2** Removing a Board from a Twin Tower Chassis3-3
- Figure 3-3** Removing a Board from a Rackmount System3-4
- Figure 3-4** Opening the Front Door3-5
- Figure 3-5** Opening the I/O Door3-6
- Figure 3-6** Removing a Board from a Single Tower Chassis3-7
- Figure 4-1** Removing a SIMM4-2
- Figure 4-2** SIMM Blocks and Sockets4-3
- Figure 4-3** Location of SIMM Bank 1 on IP17 Board4-4
- Figure 4-4** High-density SIMM Configurations on the IP17 Board4-6
- Figure 4-5** Low-density SIMM Configurations on the IP17 Board4-7
- Figure 4-6** Mixed High- and Low-density SIMM Configurations on the IP17 Board4-8
- Figure 4-7** Mixed High- and Low-density SIMM Configurations on the IP17 Board4-9
- Figure 4-8** Installing SIMMs4-11
- Figure 5-1** IP17 Board Jumper5-2

Tables

Table 2-1	HU-4DCR75CPC Upgrade Kit Contents2-1
Table 4-1	Allowable SIMM Combinations on the IP17 Board4-5
Table 5-1	IP17 Slot Assignment5-3
Table 6-1	Determining the Proper Software Version for a System6-3
Table 7-1	International SkyNet Branch Offices and Phone Numbers7-4

Chapter 1

Introduction

This document describes the procedures used to upgrade an existing Silicon Graphics® R4000-50 POWER Series™ system to an IRIS® R4400-150 system containing an IP17 central processing unit (CPU) board. The IP17 CPU board contains a single 150MHz, 64-bit R4400 RISC CPU and a floating point coprocessor. The IP17 can operate in all POWER Series systems; however, it does not operate in systems containing other memory (other than an MC2) or processor boards (other than an IO3B). A R4400-150 system is a single CPU board configuration, similar to the R4000-50 system. You cannot add more than one R4400-150 into a system.

Caution: This upgrade applies only to existing R4000-50 systems. If your customer has any other type of system and wishes to convert it to an R4400-150, he or she must *first* upgrade the system to the R4000-50 level *before* an R4400-150 CPU board can be installed. See the *IRIS POWER Series R4000-50 (IP17) Upgrade Installation Instructions* (P/N 108-7031-xxx) for further information.

Note: The memory required to operate the CPU is located directly on the IP17 board. However, this upgrade does not come with any memory installed on the IP17 board. During the upgrade procedure, you must move the memory modules from the old CPU board to the new IP17 board. The IP17 can be populated with both high- and low-density memory in various combinations from 16MB up to a maximum of 256MB. A minimum of 16MB is required for CPU operation. Memory configurations are described in more detail in Chapter 4, “Configuring Memory.”

The HU-4DCR75CPC kit upgrades all the R4000-50 POWER Series systems (including Twin Tower systems). In addition, the R4400-150 processor does not require a fan cooling assembly, as was the case with the R4000-50 version. The general procedures required to complete this upgrade are described in Chapter 2. Once you are familiar with the steps, proceed to Chapters 3, 4, 5, and 6.

Note: The IRIS R4400-150 system must run operating system Release IRIX™ 4.0.5H or 4.0.5J, whichever version is applicable to your system (see Chapter 6, “Verification and Testing,” for additional information). If your customer does not have the required software, you must order the operating system software. Do not begin the upgrade until you have all of the required hardware and software.

1.1 IP17 Features

The IP17 board has a single R4400 processor running internally at 150MHz and a memory subsystem that is compatible with the current GTX and PowerVision™ graphics subsystems. An oscillator on the IP17 board that is external to the R4400 processor, runs at a 75MHz clock rate. The IP17 is a triple-height, full-depth Eurocard board that connects to the existing backplane (MP bus) through three standard 96-pin DIN connectors. The board contains a mixture of surface-mount and through-hole integrated circuits (ICs).

The board has the following major functional elements:

- a 150MHz R4400 processor, with an interface to secondary cache (1MB or 4MB)
- 16MB to 256MB of on-board memory
- an R4400-to-MP bus interface ASIC that allows the R4400 to perform MP bus PIO read and write operations, MP bus three-way transfer operations for high-speed graphics performance, and MP bus memory read and write operations for uncached access to local memory
- an R4400-to-memory interface ASIC allowing an interface to on-board memory that supports a 32-word secondary cache line size
- an MP bus-to-memory interface ASIC that allows MP bus read and write operations to memory
- four dynamic RAM control (DCC) ASICs that fulfill the high bandwidth requirements of the R4400
- a sync bus interface
- 1MB of EPROM
- four RS-232 ports

Figure 1-1 shows a block diagram of the IP17 board. The memory system consists of four dynamic RAM control ASICs (DCCs), 32 single in-line memory module (SIMM) sockets, and discrete DRAM address and control-line buffers. The DCCs convert the 256-bit wide memory array into two 64-bit buses.

The on-board memory is expandable from 64MB to 256MB, using high-density (HD) 8MB SIMMs, or from 16MB to 64MB, using low-density (LD) 2MB SIMMs. Low-density and high-density SIMMs can be installed on the same IP17 board, but the high-density SIMMs must occupy the lowest memory location. The minimum memory configuration is eight 2MB SIMMs (see Chapter 4, “Configuring Memory”).

The IO3B board is required for this upgrade because of modifications made to the MP bus arbiter on the board to allow the R4400 default access to the local memory.

Caution: The IP17 works only with the IO3B board. You must use an IO3B board. Do not try to substitute a standard IO3 board.

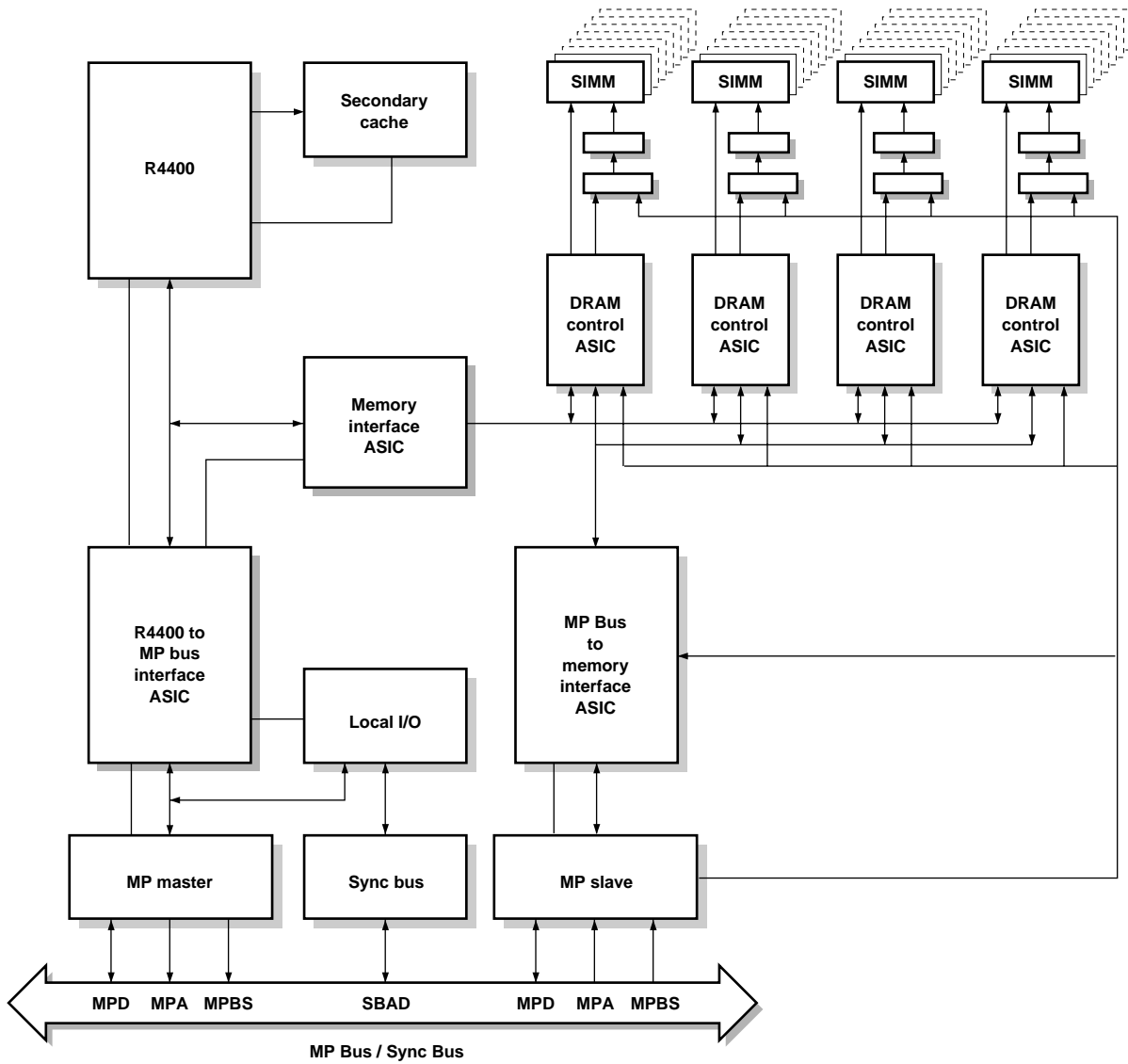

Figure 1-1 Block Diagram of IP17 Board

1.2 IP17 Board Connectors and Indicators

The IP17 board has a total of 32 SIMM sockets that can accept either 2MB or 8 MB SIMMs. The board also has three backplane connectors, a 64-pin ribbon cable connector, and power and status indicators as shown in Figure 1-2.

Note: The IP17 has an extra large heat sink installed directly on top of the R4400 for cooling purposes.

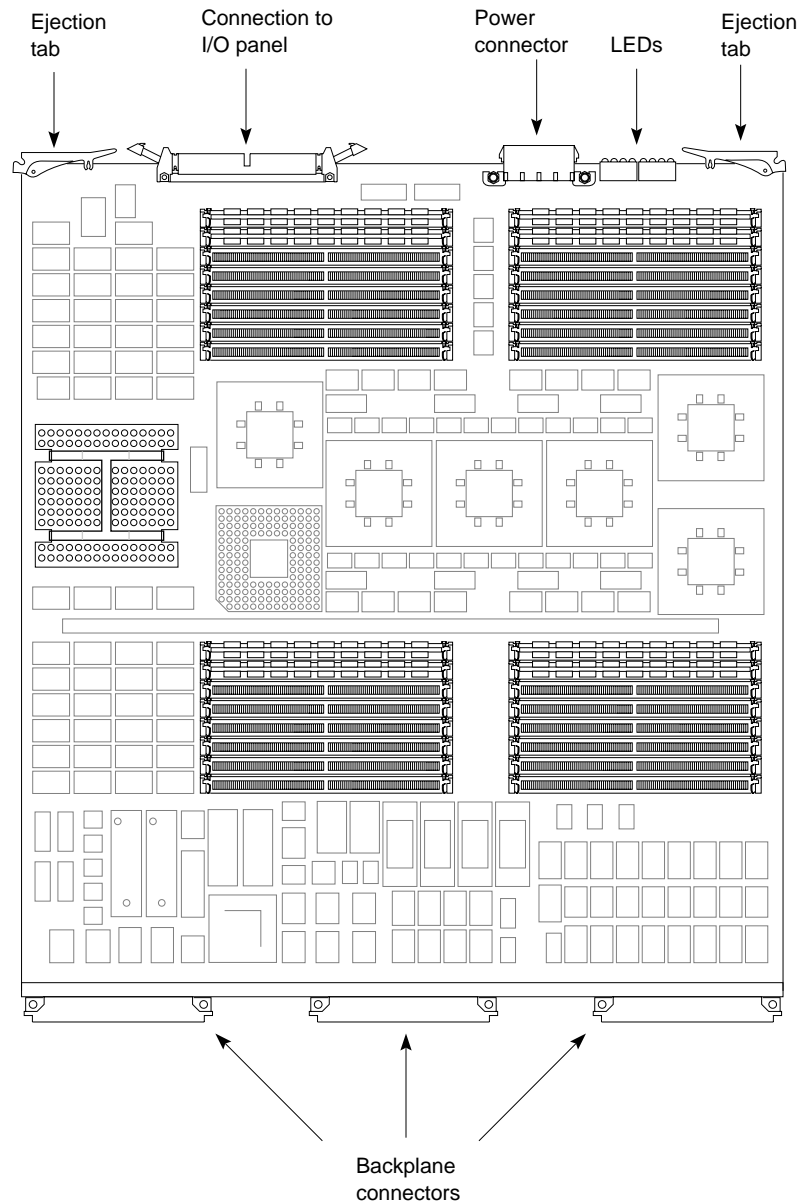

Figure 1-2 Connectors and Indicators

Chapter 2

Kit Contents

Verify that you have all of the components listed below before the customer's files are backed up and the system is powered off.

Note: The IP17 comes without memory. If the customer does not have at least 16MB of memory on the existing processor or memory boards, more memory must be ordered before you can install the IP17 board. In addition, the IRIX 4.0.5H or IRIX 4.0.5J operating system software must be either installed or available for installation on your customer's system. See Chapter 6, "Verification and Testing," for additional information on which operating system version to use for your system.

2.1 HU-4DCR75CPC Kit Contents

Upgrade kit product number HU-4DCR75CPC contains the items listed in Table 2-1.

Part Number	Quantity	Description
030-0512-xxx	1	IP17 board (150MHz) without memory
090-0009-xxx	1	Shipping container
7570001	1	Static bag
090-0046-xxx	1	Shipping box
SC4-S4D-4.0.5	1	IRIX server, CD/manuals, 4.0.5
7570012	1	Transparent static shield

Table 2-1 HU-4DCR75CPC Upgrade Kit Contents

2.2 Safety



Warning: Installation of these upgrades requires specific training and technical knowledge. These instructions are provided for use by Silicon Graphics system support engineers or other Silicon Graphics-trained personnel only. This equipment utilizes electrical power internally that is hazardous if the equipment is improperly disassembled.

Caution: This equipment is extremely sensitive and is susceptible to damage caused by electrostatic discharge (ESD). ESD is an electrical discharge (spark) caused by the buildup of electrical potential on clothing and other materials. You must use proper ESD-preventive measures.

Follow these ESD-preventive measures:

- Connect a ground strap to your wrist when connecting/disconnecting peripherals.
- Be sure that you and all of the electrical equipment that you handle during this installation remain at a ground potential of zero to avoid damage from ESD.
- Remove a board from its antistatic bag only when you are properly grounded with a ground strap, and only when you are working on the board or installing it.
- Do not use an ohmmeter on a board.

2.3 HU-4DCR75CPC Upgrade Steps

The HU-4DCR75CPC kit is used to upgrade all R4000-50 POWER Series systems to an R4400-150 system. The steps required to complete this installation are as follows:

1. Verify that you have all of the required components before proceeding with the installation.
2. Verify that the customer's system has been backed up.
3. Power off the system.
4. Open the I/O door of the system.
5. Remove the old IP17 board.
6. Move the memory SIMMs from the old R4000-50 IP17 to the new R4400-150 IP17 board. If enough memory (16MB minimum) is not available, additional memory must be ordered and installed before the board is installed.

Note: Check if a jumper is installed on the new IP17 board at location B0O9. Remove, if present. See Chapter 5, "Installing the Board."

7. Install the new IP17 board.
8. Remove and replace the top-hat and system labels.
9. Close the I/O door.
10. Run IDE diagnostics, and verify the new configuration using the *hinv* command.
11. Install and verify the IRIX 4.0.5H or 4.0.5J operating system software.
12. Pack and return the old IP17 board.

Chapter 3

Preparing the System

This chapter describes the specific steps required to prepare your customer's system for a successful upgrade installation. The system preparation is similar regardless of the starting system. The steps are listed in the order in which they should be performed.

3.1 Tools and Materials

You will need:

- a 1/4-inch hex nut driver
- a #2 Phillips-head screwdriver
- a flat-bladed screwdriver
- an antistatic mat
- a ground strap

3.2 General Chassis Preparation

The following steps should be followed for all chassis:

1. Before upgrading, back up all data to tape or other removable media.
2. Use the correct procedure to power off the workstation. Remove the AC power cord from the back of the workstation.

3.3 Preparing a Twin Tower Chassis

Take the following steps to prepare a Twin Tower chassis:

1. Remove all of the external cords from the I/O door.
2. Remove the screws holding the I/O door in place, then open the I/O door.

Caution: Be sure you are wearing your ESD ground strap.

3. Disconnect the power cord and the 64-pin serial I/O ribbon cord connector from the old IP17 board.

Note: In the Twin Tower chassis, a special wiring harness connects the old IP17 board to the PP2 board on the I/O panel. Be sure to remove this cord. See Figure 3-1.

4. Use the board ejection tabs to remove the old IP17 board from the chassis (Figure 3-2); place it on an antistatic mat.
5. Proceed to Chapter 4 for further installation instructions.

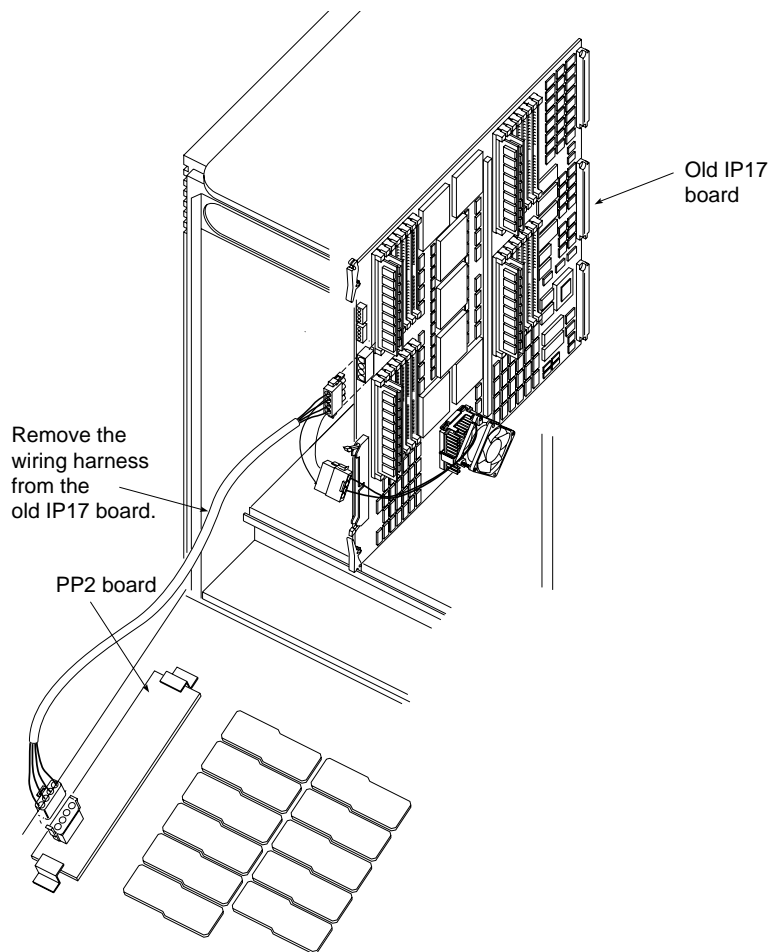

Figure 3-1 Removing the Wiring Harness from the Old IP17 Board in a R4000-50 Twin Tower

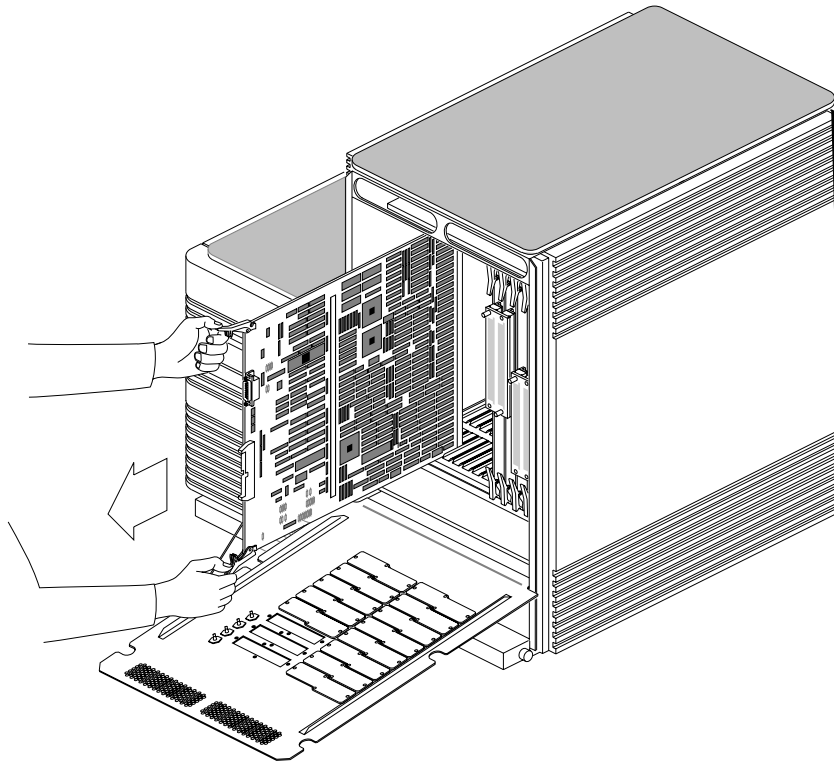

Figure 3-2 Removing a Board from a Twin Tower Chassis

3.4 Preparing a Rackmount Chassis

Take the following steps to prepare a rackmount chassis:

1. Open the upper chassis door.
2. Remove all of the external cords from the I/O door.
Caution: Be sure you are wearing your ESD ground strap.
3. Open the I/O door.
Caution: The I/O door is secured with quarter-turn fasteners. Do not turn them too far.
4. Disconnect the power cord and the 64-pin serial I/O ribbon cord connector from the old IP17 board.
5. Use the board ejector tabs to remove the old IP17 board from the chassis (Figure 3-3); place it on an antistatic mat.
6. Proceed to Chapter 4 for further installation instructions.

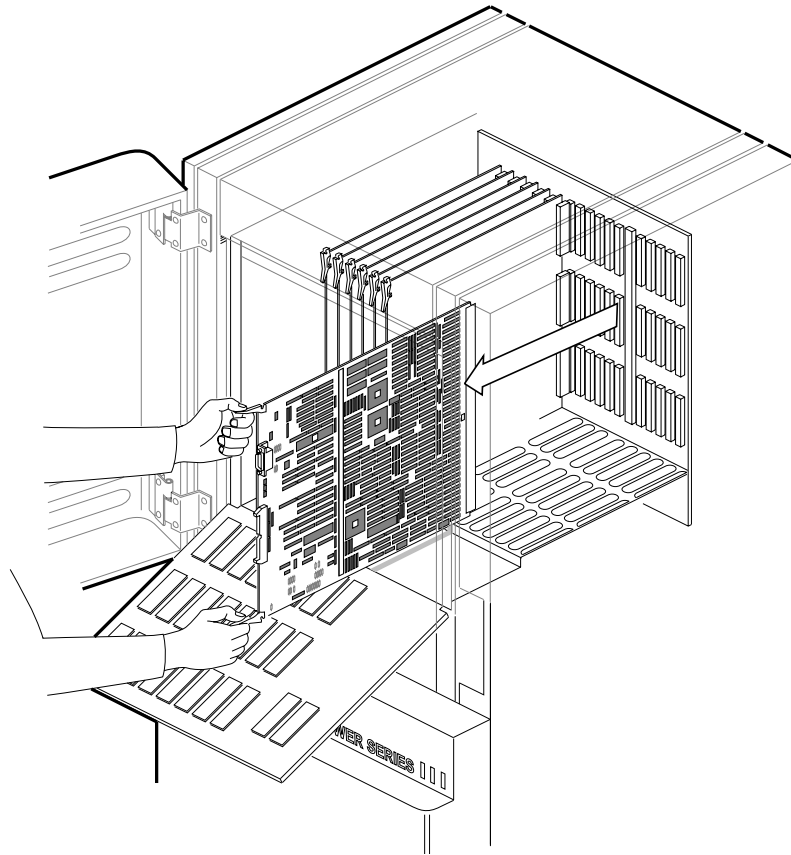

Figure 3-3 Removing a Board from a Rackmount System

3.5 Preparing a Single Tower Chassis

Take the following steps to prepare a Single Tower chassis:

1. Open the front door as shown in Figure 3-4.
2. Disconnect the external cords from the I/O door to make opening the I/O door easier.

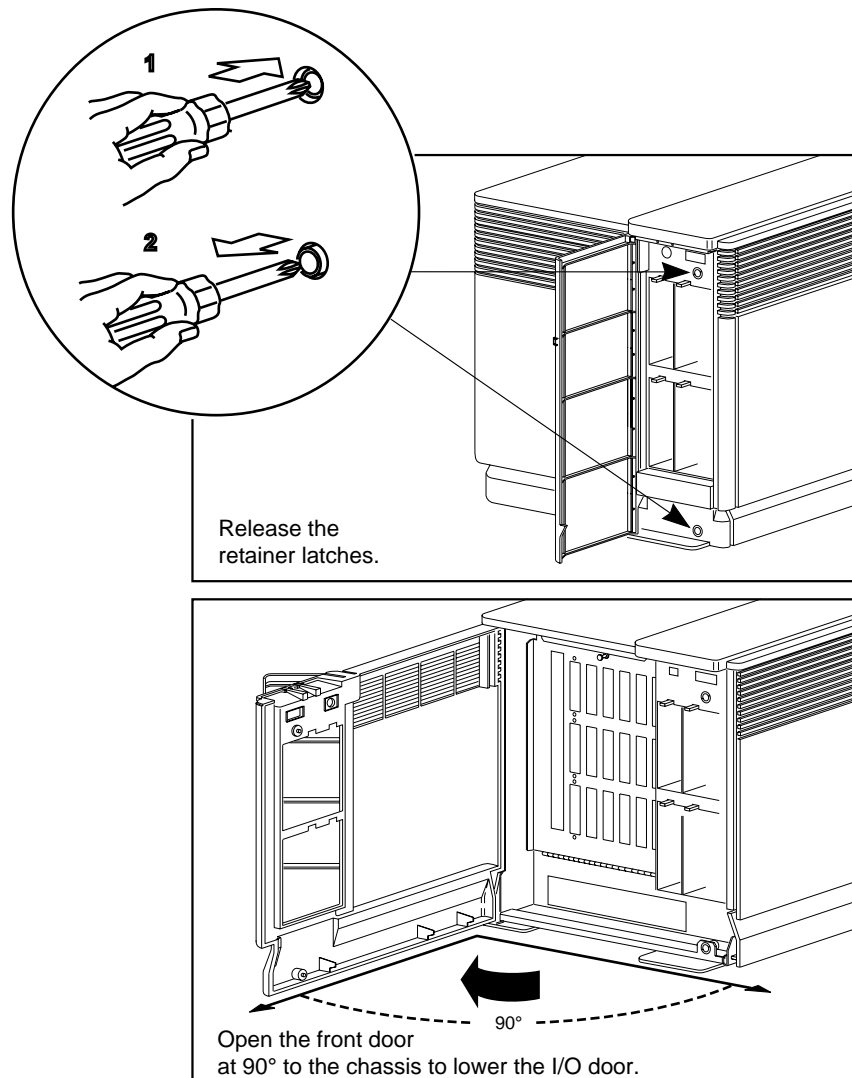

Figure 3-4 Opening the Front Door

3. Open the I/O door as shown in Figure 3-5.
4. Disconnect the 64-pin serial I/O ribbon cable connector from the old IP17 board.

Caution: Be sure you are wearing your ESD ground strap.

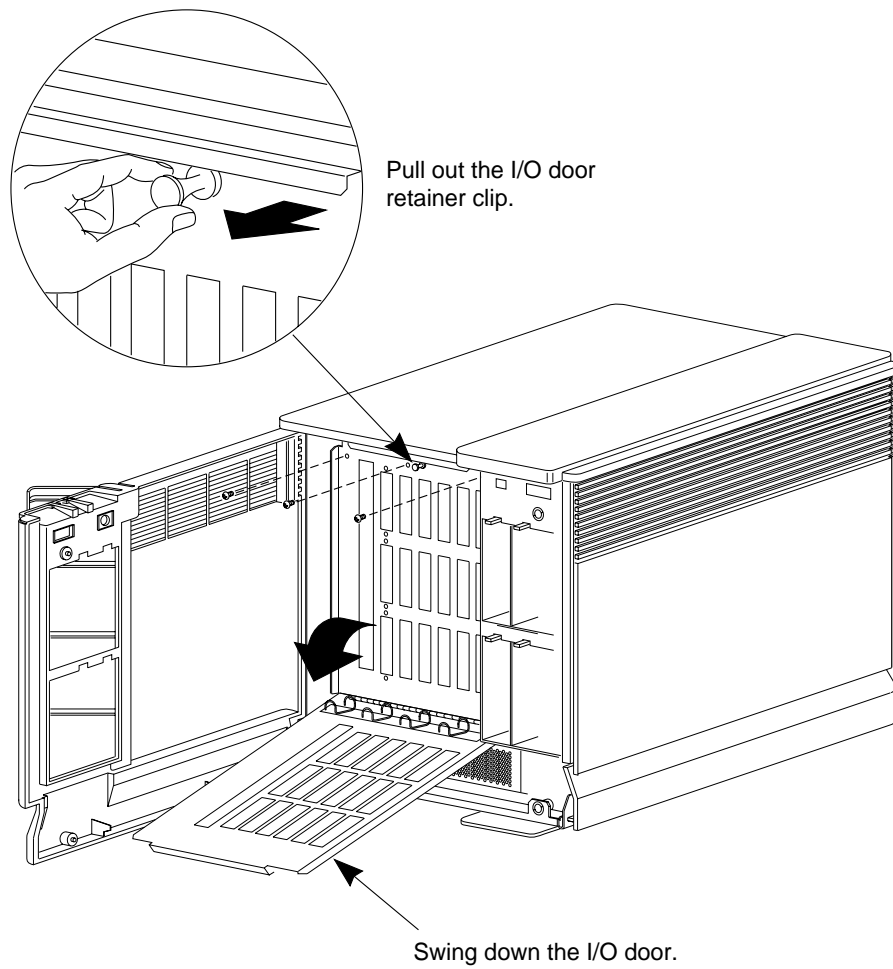

Figure 3-5 Opening the I/O Door

5. Use the board ejector tabs to remove the IP17 board from the chassis (Figure 3-6); place it on an antistatic mat.

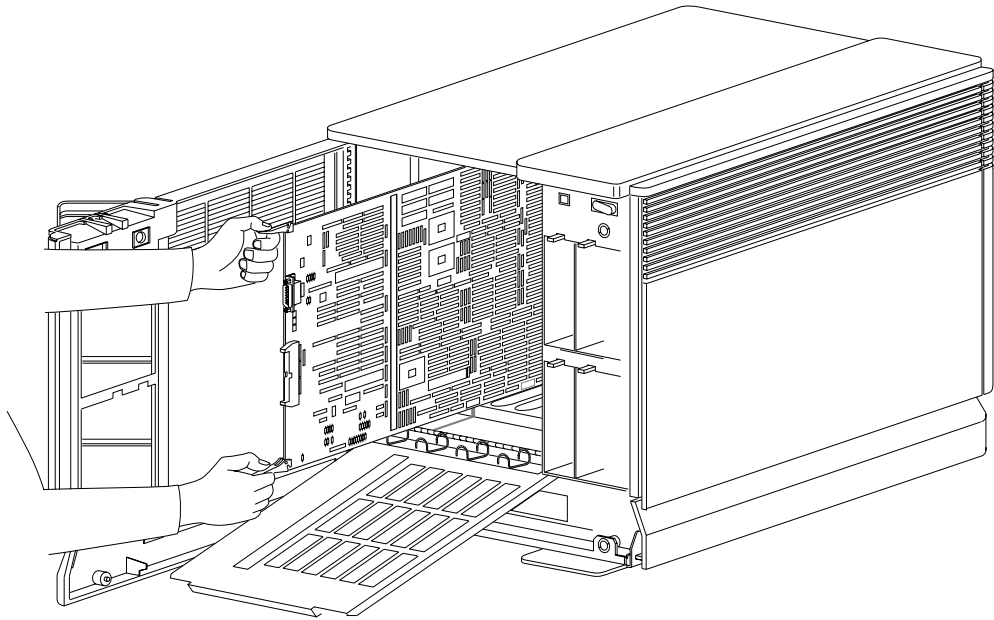

Figure 3-6 Removing a Board from a Single Tower Chassis

6. Proceed to Chapter 4 for further installation instructions.

Chapter 4

Configuring Memory

This chapter describes how to install and configure memory on the IP17 board. No single in-line memory modules (SIMMs) are installed on the IP17 board as it is shipped in the kit. You must remove the existing SIMMs from the system you are upgrading and install them onto the IP17 board.

4.1 Tools and Materials

The only tool you may need when removing and installing SIMMs is a flat-bladed screwdriver.

4.2 Removing SIMMs

Follow the steps below to remove SIMMs from the old IP17 board of the system you are upgrading. These SIMMs will be installed onto your new R4400-150 IP17 board, as described later in this chapter.

Caution: Be sure you are wearing your ESD ground strap.

1. Place the old IP17 board from the system you are upgrading on an antistatic mat, along with your new IP17 board.
2. With the IP17 board in front of you, gently spread apart the release tabs on both sides of each SIMM slot; you can use a small, flat-bladed screwdriver if necessary.
3. Carefully rotate the SIMM away from the tabs and mounting pins.
4. Once the SIMM is rotated, pull the module out toward you.
5. Store the SIMM in an ESD-safe location for later installation.

This procedure is shown in Figure 4-1.

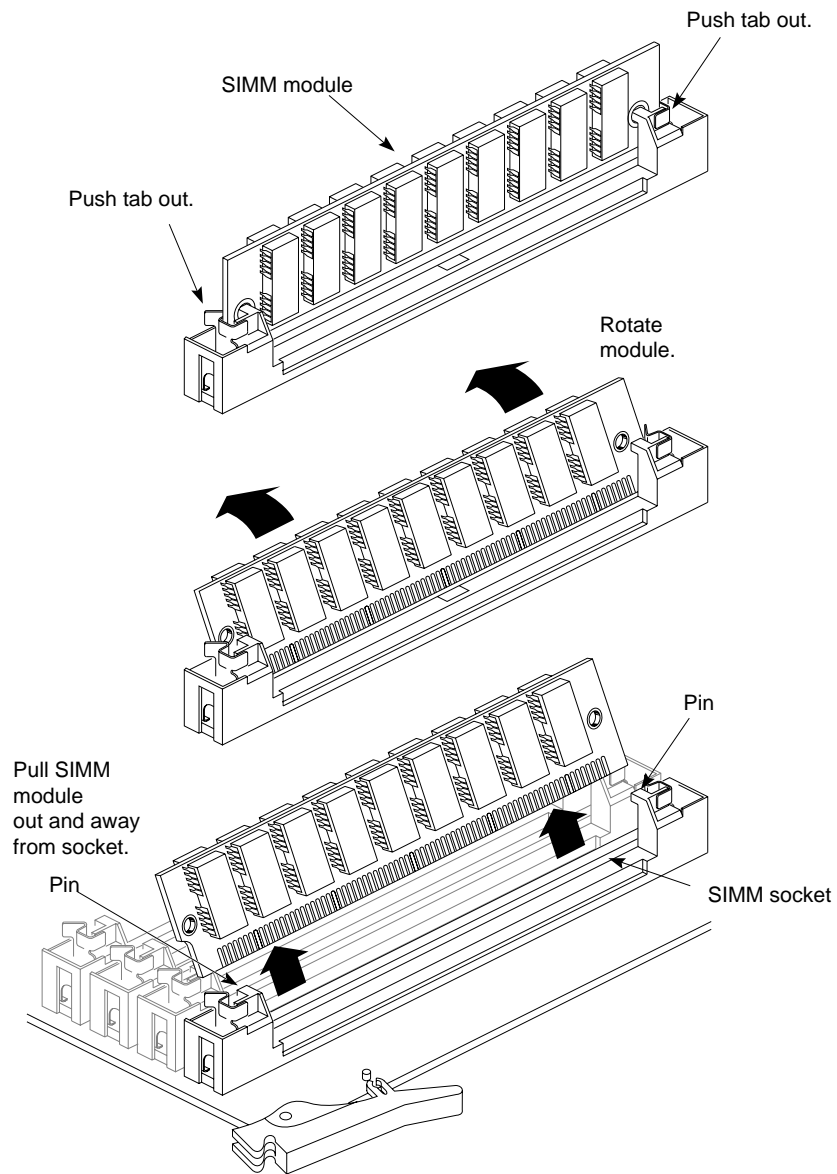

Figure 4-1 Removing a SIMM

4.3 IP17 SIMM Configuration

SIMMs must be installed in the correct configuration. Refer to the following paragraphs to correctly configure the memory of your IP17 board.

4.3.1 SIMM Blocks and Banks

The IP17 board has 32 SIMM sockets organized into four groups, or blocks. All four blocks are identical. Each block consists of eight SIMM sockets, and every two sockets compose a single bank. Thus, there are four banks in each SIMM block (see Figure 4-2).

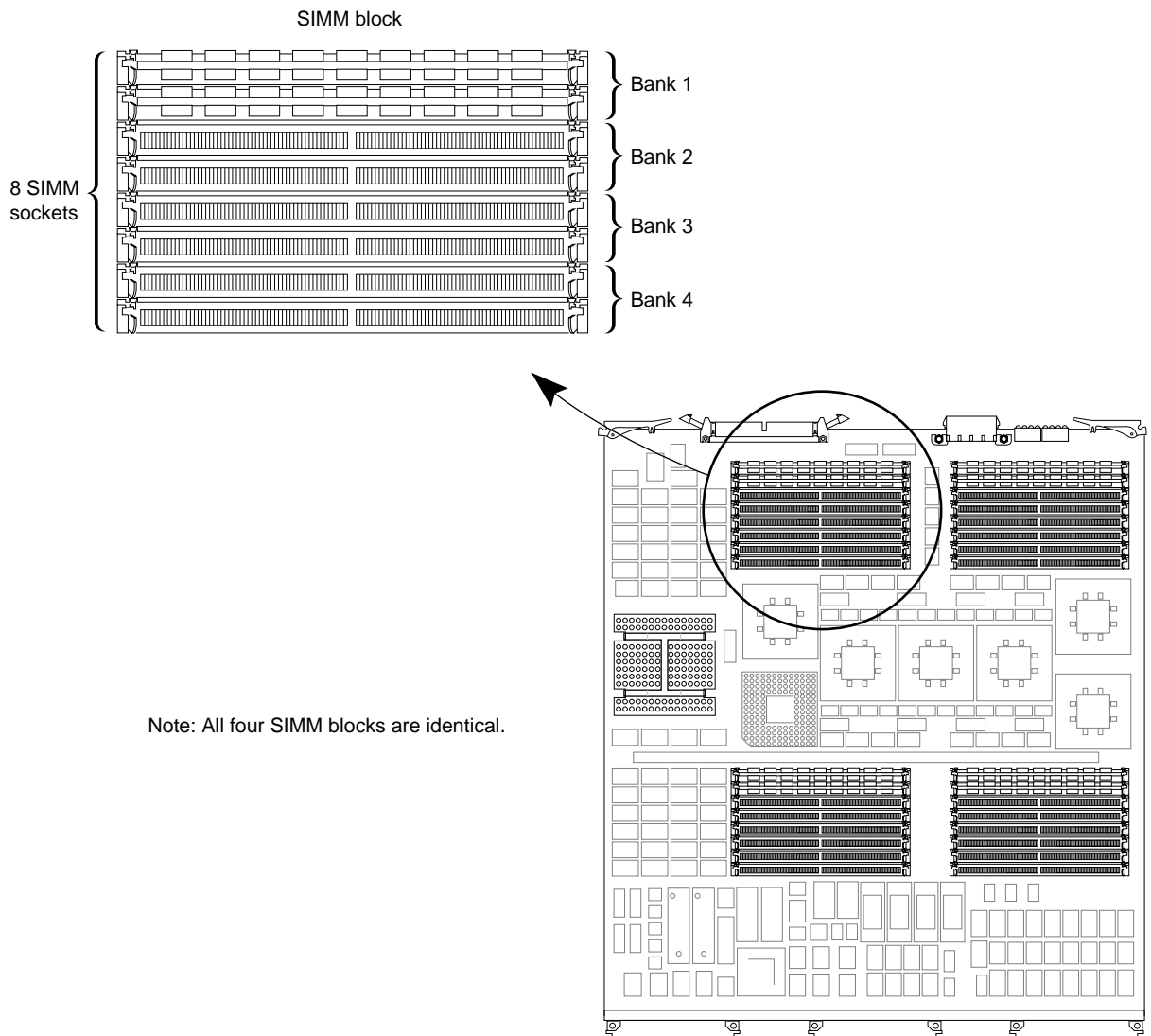

Figure 4-2 SIMM Blocks and Sockets

4.3.2 Allowable SIMM Combinations

When SIMMs are loaded onto the board, bank 1 in each block must be filled first. SIMMs must be installed in groups of eight, as shown in Figure 4-3.

Caution: All eight SIMMs in a given location must be of the same type, either high density or low density. When the system diagnostics are invoked, only one of the eight SIMMs in a given location is verified. If high-density and low-density SIMMs are mixed, memory errors occur.

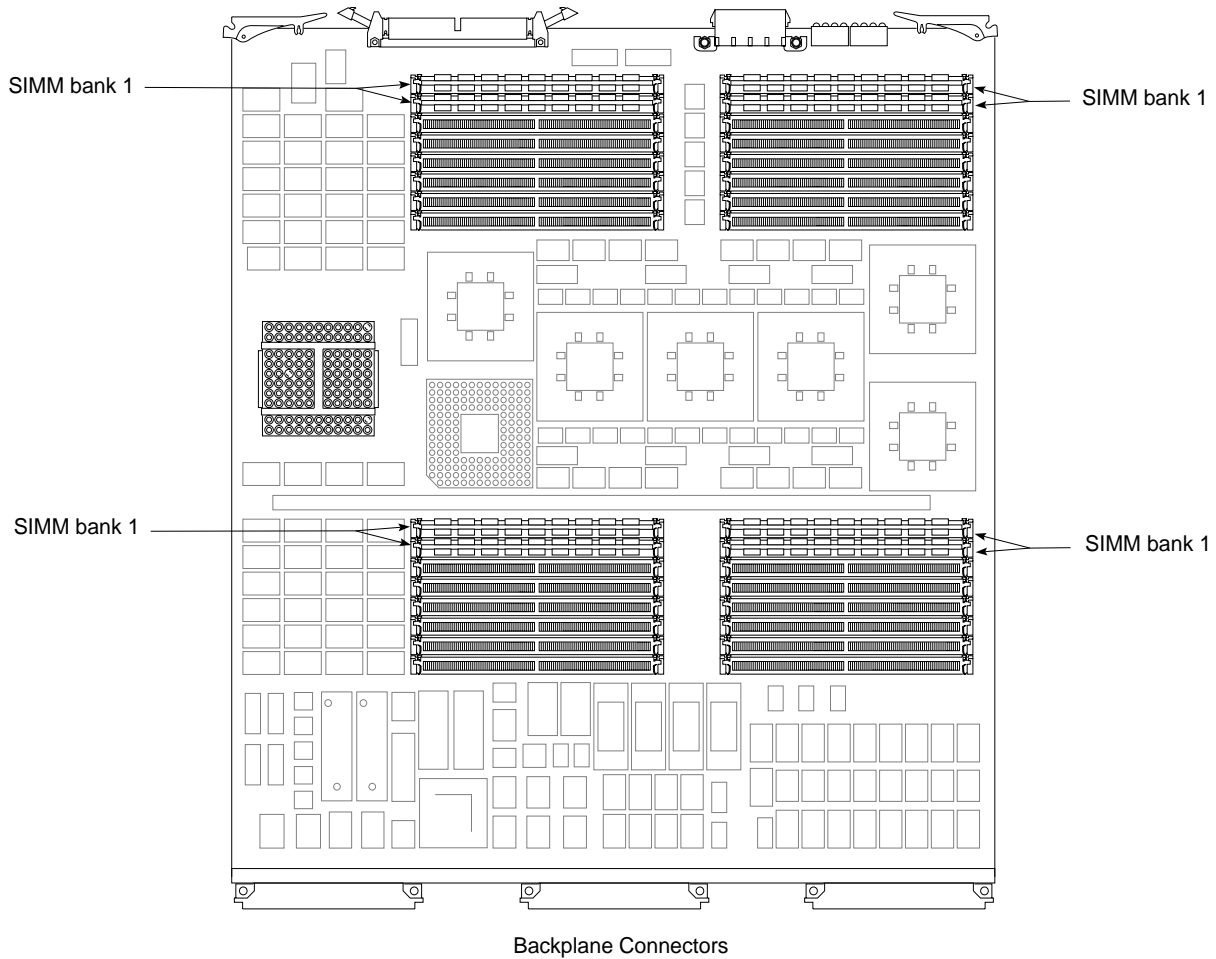

Figure 4-3 Location of SIMM Bank 1 on IP17 Board

The high-density SIMMs contain 8MB each and are installed 64MB at a time (8 SIMMs times 8MB/SIMM). Low-density SIMMs contain 2MB each and are installed 16MB at a time (8 SIMMs times 2MB/SIMM). High-density and low-density SIMMs can be combined on the same block, but only when the high-density SIMMs are installed in the lowest-numbered banks (see Table 4-1).

Fourteen different combinations of high-density and low-density SIMMs can be loaded on an IP17 board. All allowable SIMM combinations are shown in Table 4-1.

Number of SIMMs Installed	SIMM Bank 1	SIMM Bank 2	SIMM Bank 3	SIMM Bank 4	Total Memory Installed
8	L-Density	—	—	—	16MB
16	L-Density	L-Density	—	—	32MB
24	L-Density	L-Density	L-Density	—	48MB
32	L-Density	L-Density	L-Density	L-Density	64MB
8	H-Density	—	—	—	64MB
16	H-Density	H-Density	—	—	128MB
24	H-Density	H-Density	H-Density	—	192MB
32	H-Density	H-Density	H-Density	H-Density	256MB
16	H-Density	L-Density	—	—	80MB
24	H-Density	L-Density	L-Density	—	96MB
32	H-Density	L-Density	L-Density	L-Density	112MB
24	H-Density	H-Density	L-Density	—	144MB
32	H-Density	H-Density	L-Density	L-Density	160MB
32	H-Density	H-Density	H-Density	L-Density	208MB

Table 4-1 Allowable SIMM Combinations on the IP17 Board

Note: It is very difficult to distinguish visually between low- and high-density SIMMs. Upon close inspection, you will note that the high-density SIMMs are slightly thicker. The best method to distinguish between the two is to check the part number:

- Low-density (2MB) SIMMs have part number 030-0133-xxx.
- High-density (8MB) SIMMs have part number 030-0184-xxx.

4.3.3 High-density SIMM Configurations

Figure 4-4 shows how high-density (8MB) SIMMs are installed on the IP17 board. A minimum of eight SIMMs (64MB) can be installed.

Caution: Regardless of the number of SIMMs installed, the same number of banks must be filled in each block. When SIMMs are loaded onto the board, the lowest numbered bank must be filled first.

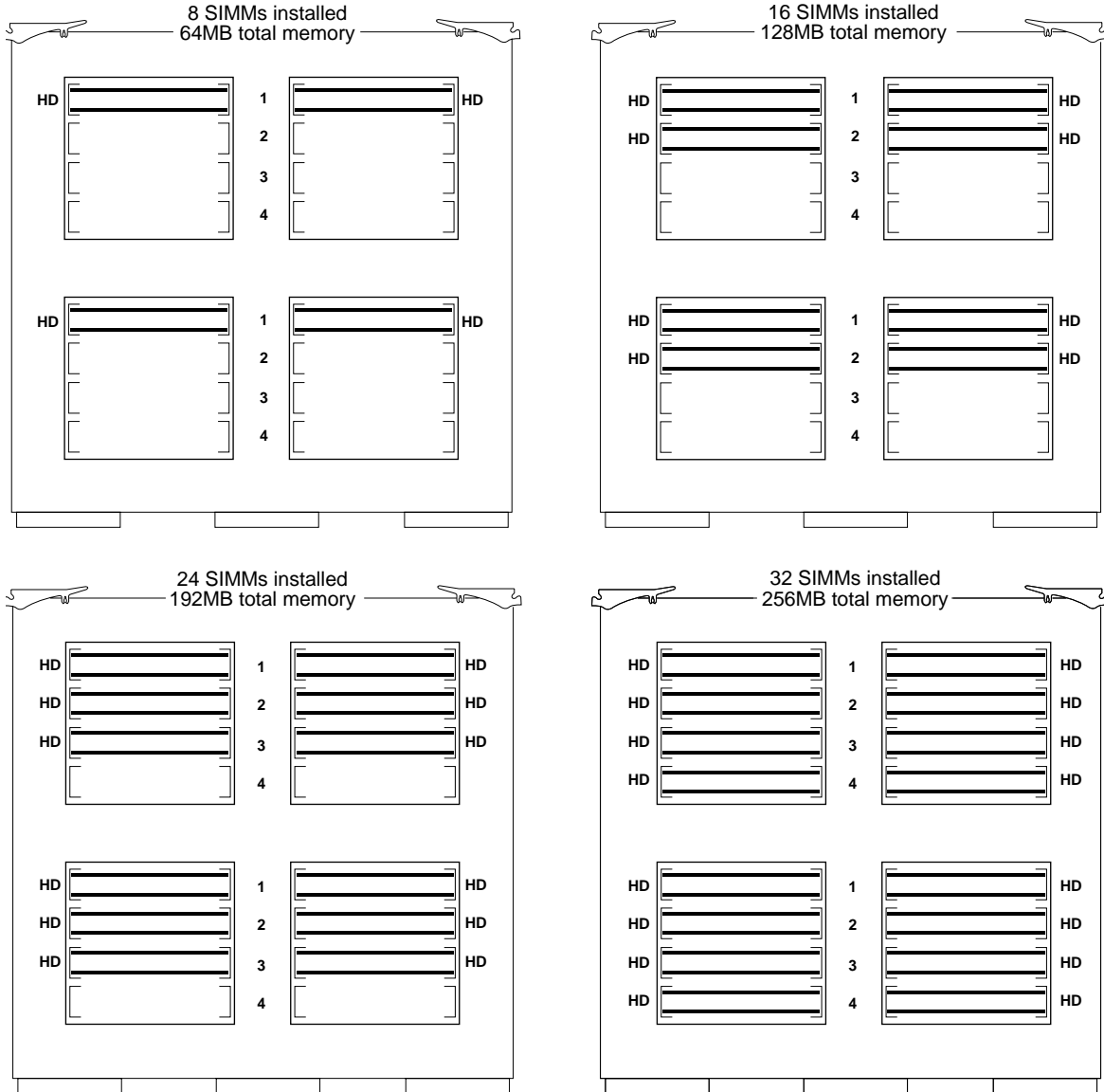

Figure 4-4 High-density SIMM Configurations on the IP17 Board

4.3.4 Low-density SIMM Configurations

Figure 4-5 shows how low-density (2MB) SIMMs are installed on the IP17 board. A minimum of eight SIMMs (16MB) can be installed.

Caution: Regardless of the number of SIMMs installed, the same number of banks must be filled in each block. When SIMMs are loaded onto the board, the lowest numbered bank must be filled first.

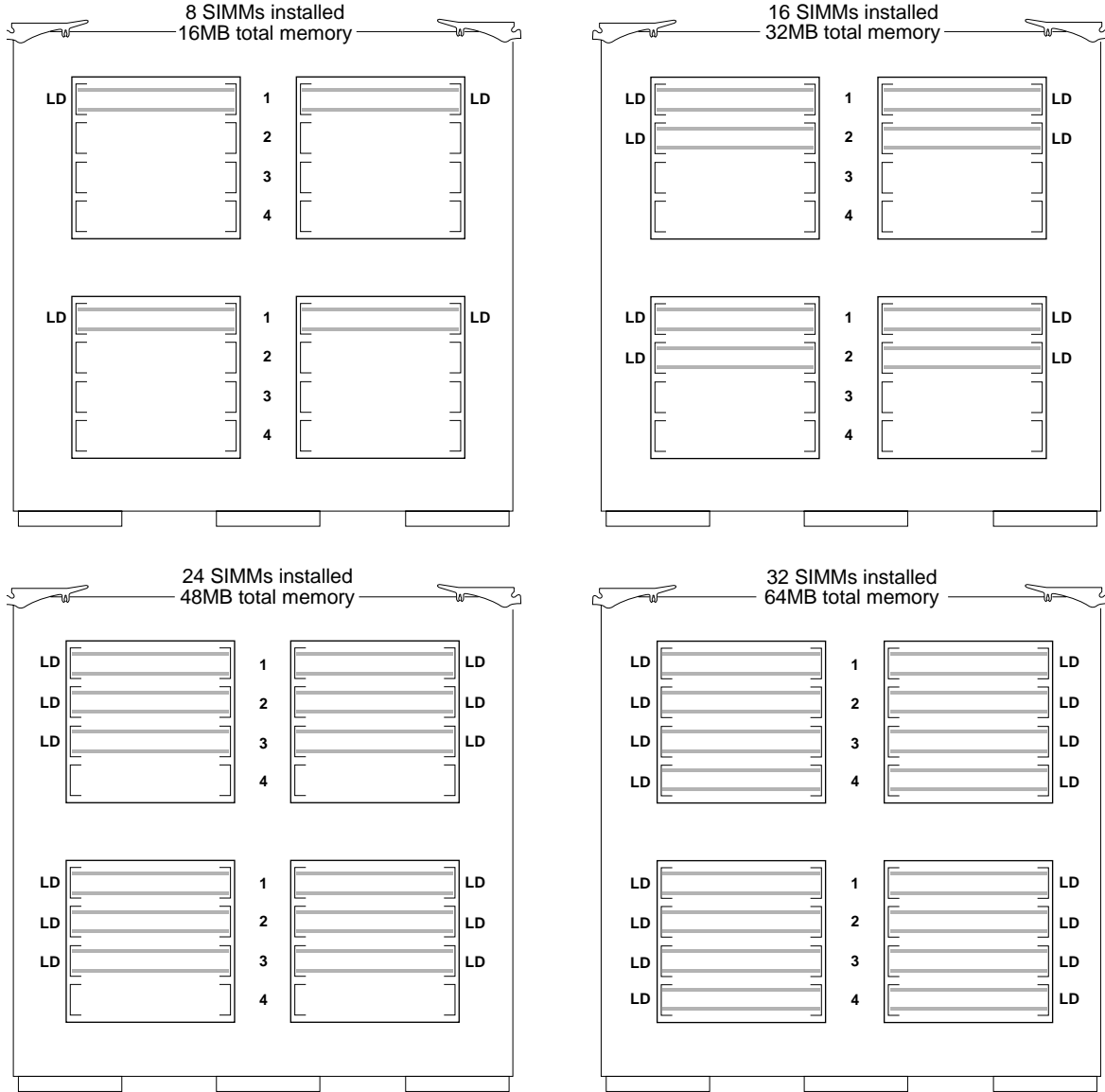

Figure 4-5 Low-density SIMM Configurations on the IP17 Board

4.3.5 Mixed High- and Low-density SIMM Configurations

Figure 4-6 shows how combinations of high- and low-density SIMMs are installed on the IP17 board. These examples show the minimum number of 8MB SIMMs along with different combinations of 2MB SIMMs that can be installed on the board.

Caution: Regardless of the number of SIMMs installed, the same number of banks must be filled in each block. When SIMMs are loaded onto the board, the lowest numbered bank must be filled first.

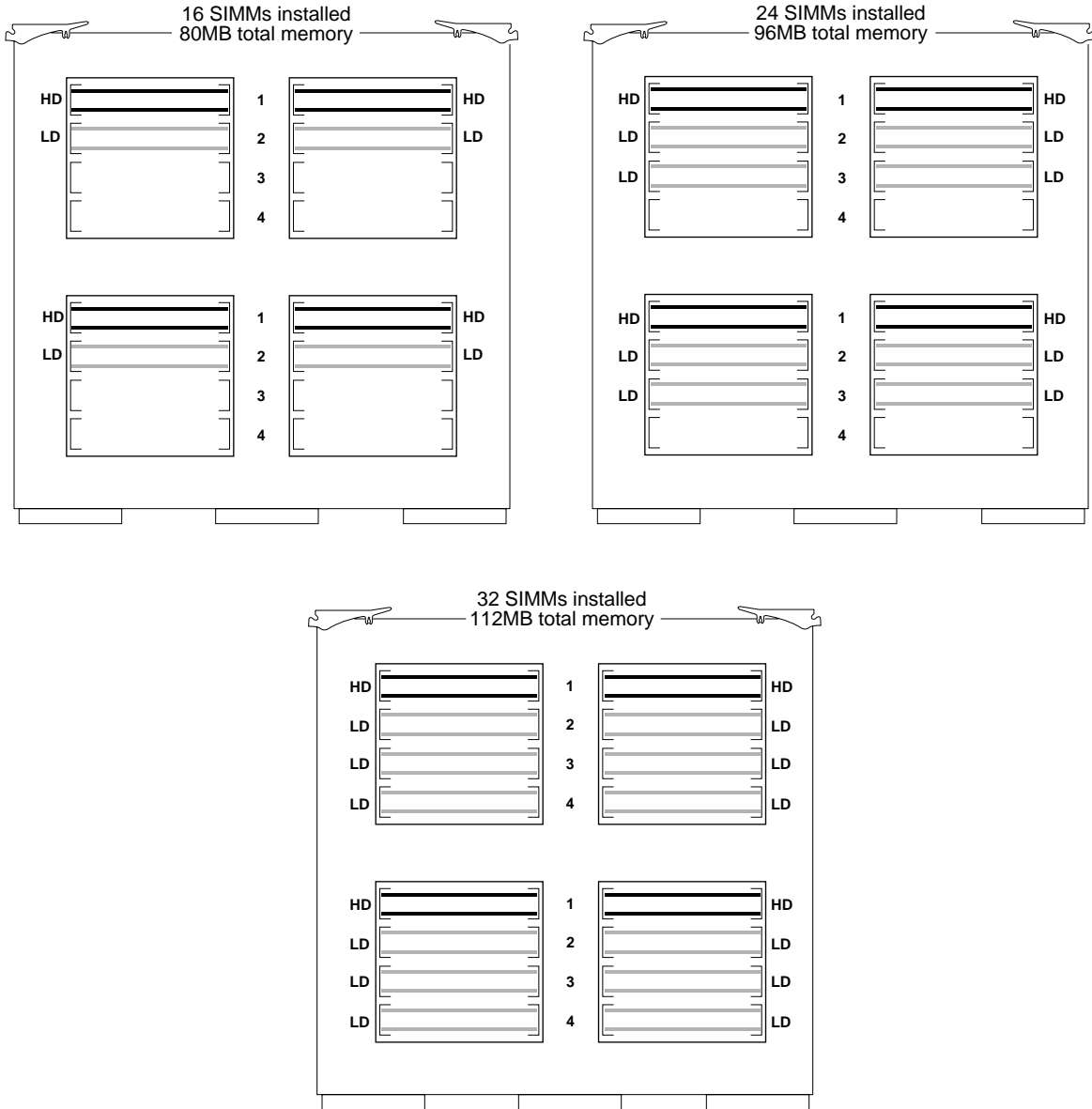

Figure 4-6 Mixed High- and Low-density SIMM Configurations on the IP17 Board

Figure 4-7 shows more examples of high- and low-density SIMMs installed on the IP17 board. These examples show groups of 16 to 24 8MB SIMMs and groups of 8 to 16 2MB SIMMs.

Caution: Regardless of the number of SIMMs installed, the same number of banks must be filled in each block. When SIMMs are loaded onto the board, the lowest numbered bank must be filled first.

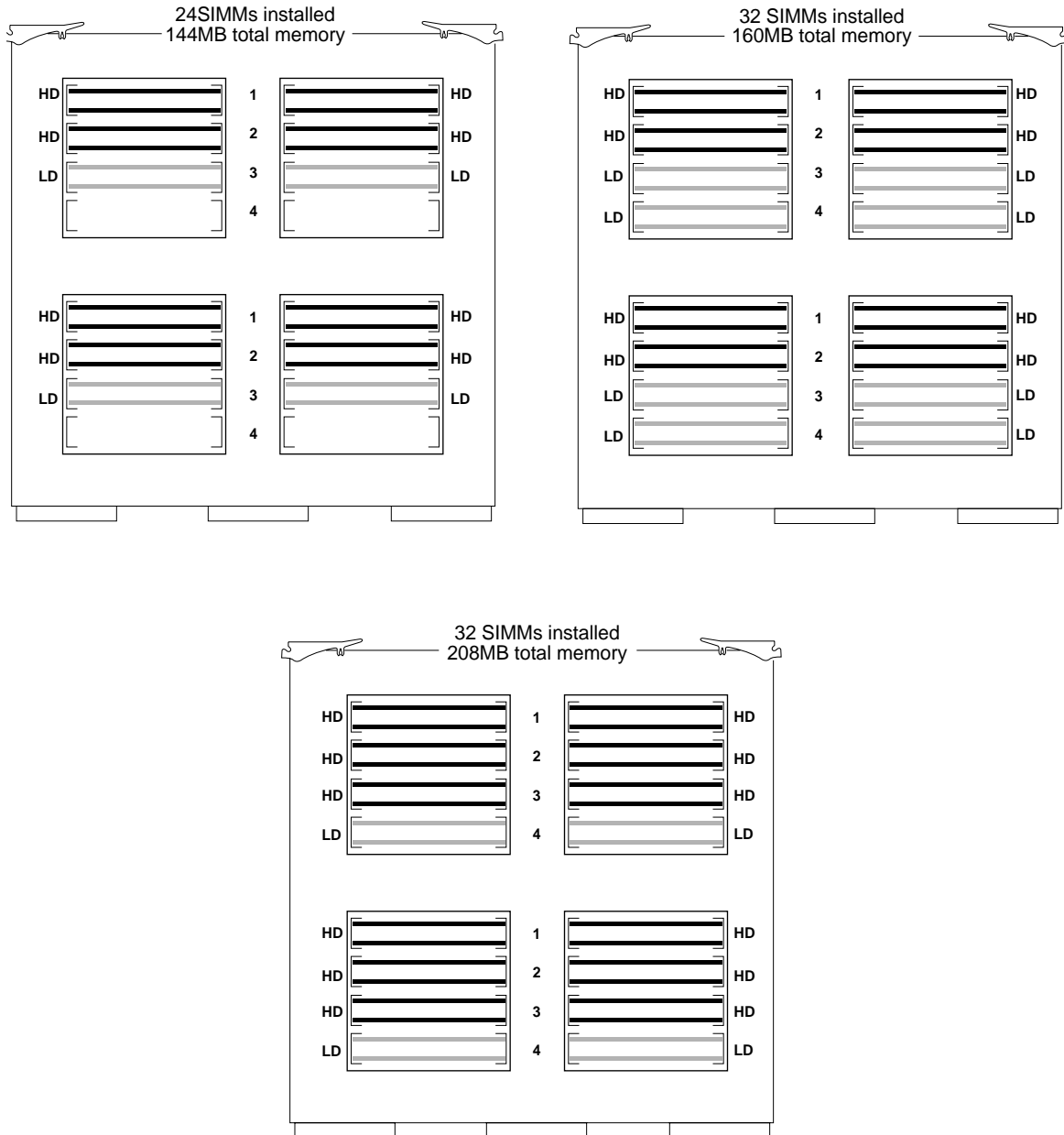

Figure 4-7 Mixed High- and Low-density SIMM Configurations on the IP17 Board

4.4 Installing SIMMs

Once you have decided on the proper SIMM configuration, you can install the SIMMs on the IP17 board. Install eight SIMMs at a time, two in each corresponding SIMM bank in each SIMM block. Refer to Figure 4-4 through Figure 4-7 for the proper locations. Use the following instructions to install SIMMs on the IP17 board.

Caution: Be sure you are wearing your ESD ground strap.

1. Place the IP17 board on the antistatic mat so that the board ejection tabs (on the front of the board) are closest to you.
2. You will notice that one side of the SIMM module is notched. Hold the SIMM so that this notched side is to your left.
3. Slide the SIMM module into the socket at an angle.
4. Gently rock the module back and forth until the connectors are aligned.
5. Carefully push the module down and away from you until you hear the release tabs click into the locked position.

Refer to Figure 4-8 for details on SIMM installation.

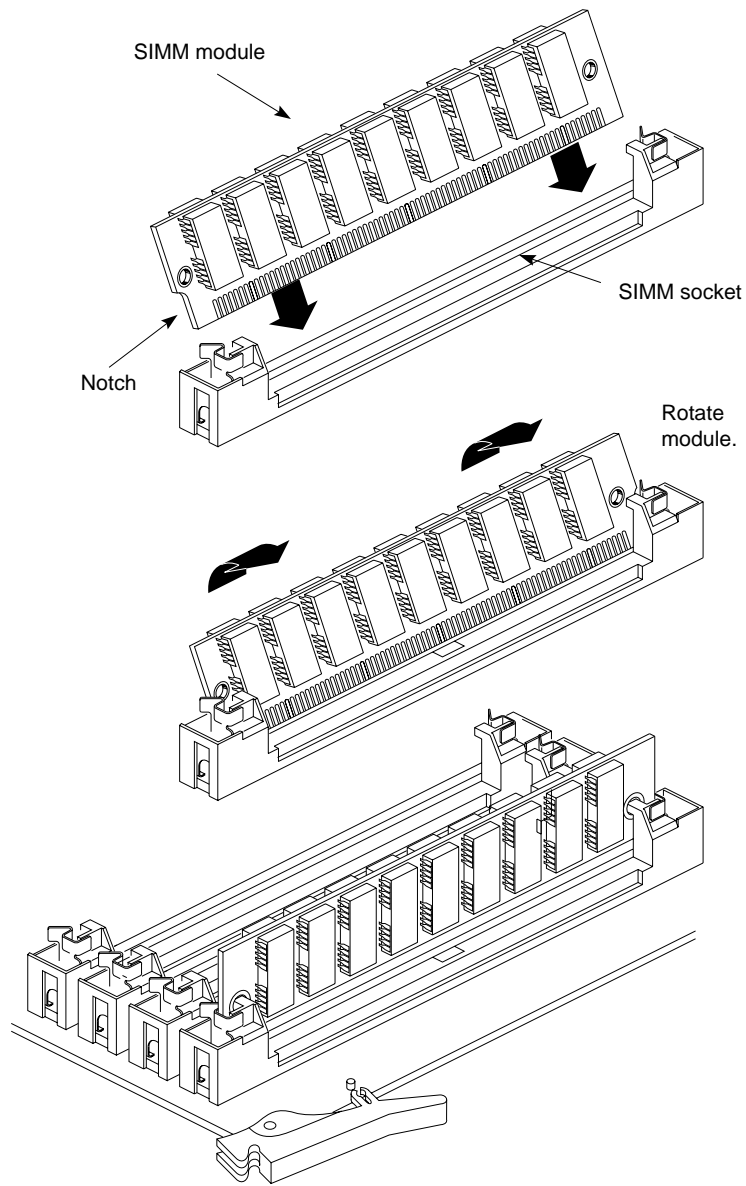

Figure 4-8 Installing SIMMs

Chapter 5

Installing the Board

This chapter describes the procedures for:

- verifying the correct jumper configuration on the IP17
- installing the new IP17 board in your chassis to convert the system into an R4400-150.

Caution: You can only add the R4400-150 upgrade to an existing R4000-50 system. You cannot install the R4400-150 board into any other system (such as a 4D/420VGX). The R4400-150 requires an IO3B board, which is already present in a R4000-50 system.

Note: You cannot add more than one R4400-150 into a system.

5.1 IP17 Jumper Verification

Make sure that there is no jumper block installed on the pins at location B0O9, as shown in Figure 5-1. If a jumper is installed, remove the jumper before installing the board in your system.

Caution: If a jumper is installed on these pins, the external 75MHz oscillator will be disabled. If no other oscillator is present, the R4400's clock input will float. Leave these pins unjumped to prevent this condition from occurring.

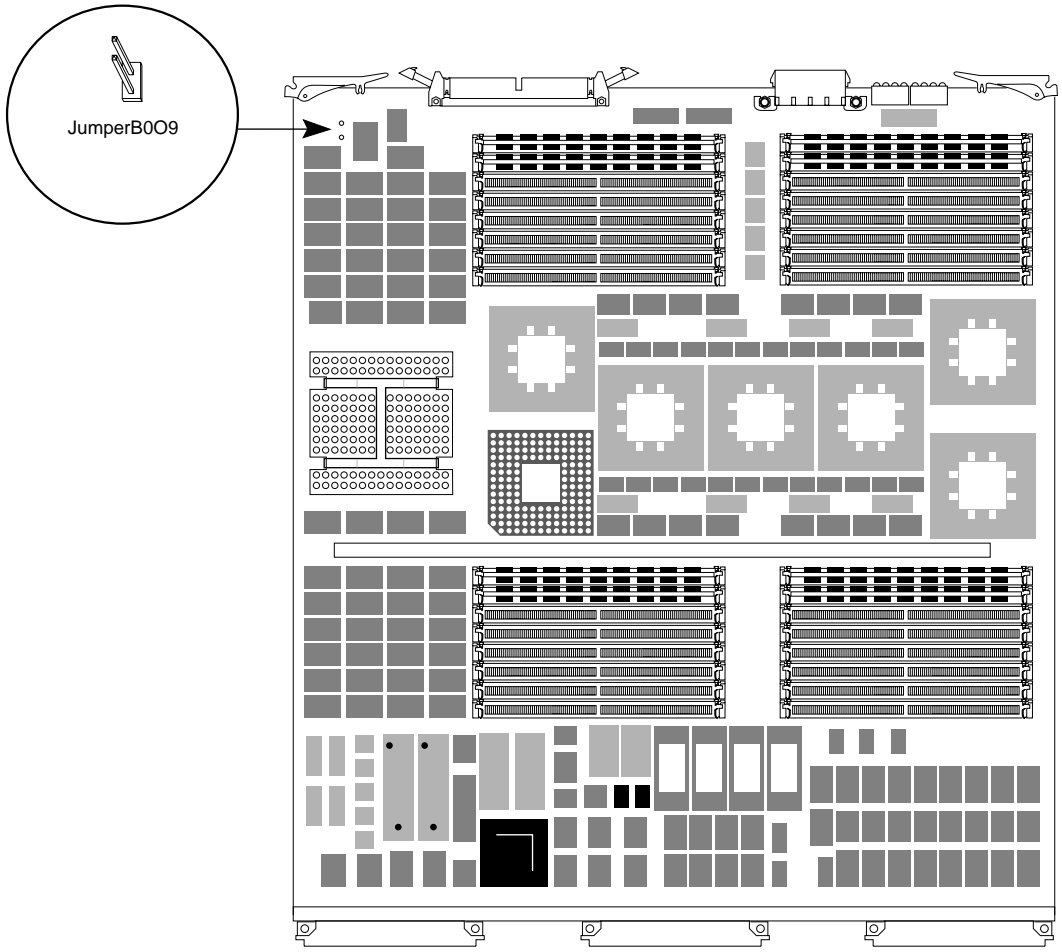

Figure 5-1 IP17 Board Jumper

5.2 Board Location

The IP17 board must be installed in a specific slot, depending upon the chassis being upgraded. Table 5-1 shows the slot locations for the IP17 board in each chassis.

Chassis	IP17
Single Tower chassis	Slot 6
Twin Tower chassis	Slot 6
Rackmount chassis (Graphics)	Slot 8
Rackmount chassis (Server)	Slot 14
Rackmount chassis (Predator 3)	Slot 8

Table 5-1 IP17 Slot Assignment

5.3 Installing the New IP17

Install the new IP17 board as follows:

1. Check the IP connectors for bent pins or other damage before inserting the IP17 board into the CPU slot. See Table 5-1.
2. Reconnect the 64-pin I/O ribbon cable to the IP17 board.
3. Reconnect any other cables that were disconnected during this installation.
4. Slide the new board into the chassis until it is completely seated.

5.4 Completing the Installation

The top-hat and system labels must be replaced to reflect the new system configuration. In addition, the system must be reassembled for customer use.

1. Peel off the existing labels from the rack and Twin Tower systems. On the Single Tower system, one way to remove the top-hat label is to insert a paper clip into the small hole under the label. The label pops right off. This works better than trying to peel off the label.
2. Use the new top-hat and system labels to reflect the new system configuration.
3. Close the I/O door.
4. Replace all of the I/O panel cables.
5. Close the front door.
6. Connect the power cord to the receptacle; turn on the circuit breaker and the power switch.

Chapter 6

Verification and Testing

Once you have installed the new hardware, you must run the new diagnostic tests to ensure its proper operation.

Caution: The R4400-150 IP17 board does not work with software versions prior to IRIX 4.0.5H or 4.0.5J. The new software must be available for installation before the system is started.

You must install the software before performing the diagnostic tests.

6.1 Bringing Up the System

After you have installed the IP17 board, follow the steps below to bring up the system:

1. Connect the main power cord to the system.
2. Connect an ASCII terminal to a serial port on the system. Ensure that the terminal is set with the following parameters:
 - 9600 baud, full duplex
 - XON/XOFF handshaking
 - 8 bits
 - 1 stop bit

3. Once you have powered on the machine, the System Maintenance Menu will appear on the ASCII terminal:

```
System Maintenance Menu

1) Start System
2) Install System Software
3) Run Diagnostics
4) Recover System
5) Enter Command Monitor
```

Option?

4. Press **5** <enter> to invoke the Command Monitor. Then enter *hinv* (hardware inventory) to ensure that the backplane and boards are recognized upon power-up. After typing *hinv* <enter>, your display should be similar to the following.

Note: You may not have exactly the same configuration shown here.

```
1 75 MHZ IP17 Processor
FPU: MIPS R4010 Floating Point Chip Revision: 0.0
CPU: MIPS R4400 Processor Chip Revision: 5.0
On-board serial ports: 4
Data cache size: 16 Kbytes
Instruction cache size: 16 Kbytes
Secondary unified instruction/data cache size: 1 Mbyte
Main memory size: 16 Mbytes
I/O board, slot F: IO3B
Integral Ethernet: et0, IO3
Integral SCSI controller 1: Version WD33C93A, revision 9
Disk drive: unit 1 on SCSI controller 0
Integral SCSI controller 0: Version WD33C93A, revision 9
Graphics board: LG1
```

Note: The 75MHz rate represents the external clock speed of the IP17 board. The R4400 processor runs at 150MHz.

5. Enter **quit** to escape back to the System Maintenance Menu.
6. After you verify the basic system configuration, you are now ready to test the board and install software.

6.2 Testing the Board

The IP17 board is tested with the stand-alone diagnostics. These are located in the directory `/stand`.

To test the IP17, you must perform the following steps:

1. Install the software.
2. Boot the diagnostics from the System Maintenance Menu.
3. Run the diagnostics.
4. Exit the diagnostics and restart the system.

These steps are discussed in detail in the following paragraphs.

6.3 Software Installation

The R4400-150 upgrade comes with two operating system versions that are available on CD:

- 4.0.5H
- 4.0.5J

Note: There is also an associated maintenance release for each operating system version. For example, in addition to the 4.0.5J operating system software CD, there is also a separate 4.0.5J maintenance CD.

Follow Table 6-1 to determine which software version is applicable to your system.

Systems Using 4.0.5H	Systems Using 4.0.5J
RealityEngine™, Extreme™, Elan™, XS, XS24	Starter, GTX, VGX, and VGXT™

Table 6-1 Determining the Proper Software Version for a System

You can install the software by downloading across a network or by using a CD-ROM locally. Refer to the appropriate software installation instructions for specific information about loading the system software.

Note: The POWER Series systems do not support any version of IRIX 5.0 at this time. However, most versions of IRIX 5.1 will support the POWER Series systems and the R4400-150 processor when they become available. See the applicable operating system release notes for more specific information regarding operating system support.

6.4 Loading and Running Diagnostics

You can now install the diagnostics directly from the following sources:

- 1/4-inch tape
- CD-ROM

Use the ASCII terminal to run diagnostics.

6.4.1 Installing the Diagnostics from 1/4-inch Tape or a CD-ROM

Follow the steps below to install diagnostics from the 1/4-inch tape or the CD-ROM:

1. Power on the system and bring up the System Maintenance Menu.
2. Select Option 3, Run Diagnostics. You will see the following display:

```
Running diagnostics ...
Type "y" to select, anything else to skip to the next selection.
```

Note: If the system detects a CD-ROM or tape drive, it will display the next message. If the CD-ROM is not installed, then only the last two lines of the following display will be shown:

```
Boot diags from CD-ROM? or
Boot diags from 1/4" tape? or
Boot diags from hard disk?
```

3. Load the operating system tape or CD-ROM.
4. Select the appropriate peripheral.
5. After you select it, you will see the following display:

```
Loading diagnostics ... (Press <ESC> to return to the menu)
```

```
.
.
.
```

```
Note: Disk Write Mode is OFF (some tests which write to disk
partition 1 are not going to run)
```

```
If you want to run these tests, please use "f k l" to turn Disk
Write Mode on, and use "f w 0" to turn the Warning Message Mode
off.
```

```
DIAGS:
```

Diagnostics are now installed on the hard disk. Before running the diagnostic tests, refer to the following paragraphs to learn how to use the commands.

6.4.2 Diagnostic Commands

The following sections briefly describe the commands that you will need to use the diagnostics program.

Help Command

The diagnostics have a number of options and commands available. To see the list of commands and options, enter `help`, `h`, or `?` at the `DIAGS` prompt:

```
DIAGS: ?
```

The following information will be displayed:

```
COMMANDS:
  auto execute:          a [TEST NAME]
  hardware configuration: c
  dump:                 d [s] [v]
  system configuration: f [p#][m RANGE][d DEVS][b#][r#][v#][s#][a#]
  help:                 h [COMMAND(s)]
  init logfile:         i
  print logfile:        l [LINES]
  menu:                 m [MENU(s)]
  quit:                 q
  execute:              x{expression[arg(s)][;expression ...]}*
                        count
                        where:
                          expression  testname[sequence][*count]
                          sequence     number | (testnumbers[*loop][,...])
                          testnumbers  number | number1-number2
```

Control Characters

The following commands can be invoked by pressing the `Ctrl` key along with the key noted:

<code>Ctrl-H</code> or <code>Del</code>	Erase single characters
<code>Ctrl-U</code>	Delete entire line
<code>Ctrl-C</code>	Suspend test

Note: Command lines take either uppercase or lowercase letters.

Menu Command

The menu command `m` displays the tests that can be executed. When invoked with no argument, the menu command displays the test categories. For example, when pressing `m` at the diagnostics menu:

```
DIAGS: m
```

the following test categories are displayed:

```
CPU TEST
BUS TEST
MEM TEST
PATH TEST
IO TEST
FPU TEST
```

6.4.3 Running the IP17 Diagnostics

In order to perform a fast and efficient verification of the IP17 board without going through every possible diagnostics test, you can run the CPU tests and memory tests 1 and 9. Follow these steps to verify the installation.

Running the CPU Tests

There are 23 CPU tests. Press `m cpu <enter>` to see the menu of all CPU tests. The screen will display the following information:

```
ptr->id cpu
mpt->desc test 8254 programming interval timer by polling, mpy->num 1
CPU1: primary D-cache TAG ram-tests
CPU2: primary I-cache TAG ram-tests
CPU3: primary I-cache functionality test
CPU4: primary cache parity test
CPU5: secondary cache ECC test
CPU6: [-dstart-delay][-sstep][-n] primary data cache hold test
CPU7: [-dstart-delay] primary data cache refresh test
CPU8: test 8254 programming interval timer by polling
CPU9: test 8254 programming interval timer by interrupt
CPU10: test TLB as a small memory array
CPU11: test if all the TLB slots respond to probes upon address match
CPU12: test for correct virtual to physical translation via a mapped TLB entry
CPU13: map each TLB entry as invalid to cause an exception when accessed
CPU14: map page non-writable, then access mapped address to cause an exception
CPU15: test matching and non-matching pid field in mapped TLB entries
CPU16: test the global bit of the mapped TLB entry
CPU17: test the uncached bit of the mapped TLB entry
CPU18: test cached vs uncached mapped TLB access
CPU19: test duarts
CPU20: CPU Counter & Compare register test
CPU21: RMP bus error interrupt test
CPU22: unmapped cached/uncached access test
CPU23: determine minimum pd-cache data-retention interval

DIAGS:
```

To run an individual CPU test, press `x cpun`, where `n` is 1 through 23. For our purposes, enter `x cpu` to run all of the tests.

Running the Memory Tests

After all of the CPU tests have been successfully run, you should then run memory tests 1 and 9. To see the memory tests that are available, enter `m mem`. The following information will be displayed:

```
ptr->id mem
mpt->desc memory sockets connection test, mpy->mi 1
mem1: memory sockets connection test
mem2: address walking test
mem3: read/write patterns
mem4: address in address memory test
mem5: walking I/O memory test
mem6: memory with ecc test
mem7: mem8 [-bhw] [-v pat] RANGE - use specified address & pattern
mem8: io3 LED test
mem9: cache write-through memory test

DIAGS:
```

To run memory test 1, enter `x mem1`.

Note: Do not leave a space between `mem` and the number of the test or the entire suite of memory tests will execute.

The following information will be displayed as you are running memory test 1:

```
running mem 1 - memory sockets connection test
(CONNECT)
mem test pass, pass count = 1, skip count = 0

DIAGS
```

To run memory test 9, enter `x mem9`. The following information will be displayed as you are executing the test:

```
running mem 9 - cache write-through memory test
(CACHEMEM)

Cached Address Test
Write 0x80ff0000's to 0x80ff0000
Verify address 0x80ff0000
Write 0x7f00ffff'x to 0x80ff0000
Verify address 0x80ff0000
mem test pass, pass count = 1, skip count = 0

DIAGS
```

To quit the diagnostics program, enter `q` or `quit` at the prompt:

```
DIAGS: q
```

Note: You will now be at the System Maintenance Menu, where you can restart the system.

Chapter 7

Returning the Old IP17 Board

All IP17 boards that have been replaced must be returned. This procedure is not optional. Shipping boxes are included in the upgrade kit; if you need more board boxes, you may have to order them before all of the boards can be returned.

7.1 Packing the Board

Pack the old IP17 board in the box provided. Ensure that the board is packed to withstand the rigors of surface and air freight transportation.

Caution: Boards must be shipped in antistatic bags.

7.2 Labeling

Label the boxes with the RMA labels provided. Make sure that the following address and the RMA numbers are clearly marked on each label:

Silicon Graphics, Inc.
Receiving Department
Building 11, Dock B
2081 N. Shoreline Blvd.
Mountain View, CA 94043
RMA number

7.3 North American Shipping Instructions

Use the following instructions to return the old IP17 in the U.S. and Canada:

1. Call Federal Express at their toll-free number: (800) 238-5355.
2. Provide the carrier with the following information:
 - a. RMA number
 - b. Sales order number
 - c. Number of pieces to ship
 - d. Total weight
 - e. Silicon Graphics destination address
3. If you need further assistance, call the Silicon Graphics Traffic Department at (415) 390-1243.

7.4 International Shipping Instructions

Use the directions described in this section to ship the old IP17 board from an international site (not the U.S. or Canada). The general shipping instructions are as follows:

1. Pack the board in the shipping container provided.
2. Complete the shipping documentation.
3. Contact the applicable SkyNet branch in your region (see Table 7-1). SkyNet is the required shipping vendor.
4. Give the package to SkyNet and retain the gold copy (last sheet) of the airway bill as your receipt.

7.4.1 Shipping Documentation

You must provide three types of shipping documents to the SkyNet shipper:

- a commercial invoice
- an international SkyNet Airway bill
- a Declaration of Free Entry of Returned American Goods

Note: This declaration should already be completed for you.

Commercial Invoice

Complete the following information:

1. Fill in the “Shipper/Exporter” section of the commercial invoice with the following information:
 - company name
 - address
 - city
 - country
2. Indicate the desired shipping date.
3. List the total number of boxes for shipment.
4. Ensure that you sign your name in the signature section of the invoice.

International SkyNet Airway Bill

Complete the form as follows:

1. Fill in the date.
2. Provide the following information:
 - company name
 - address
 - city and country
3. Provide your telephone number.
4. Sign the airway bill in the “Shipper’s Signature” section.

Afterwards, insert the three documents into the packing slip envelope and be sure to keep the gold copy (last sheet) of the airway bill.

Note: Do not seal the envelope.

7.4.2 SkyNet International Directory

See Table 7-1 to find the applicable SkyNet branch and phone number for your country.

Note: If you cannot find an appropriate SkyNet branch office, or if you have difficulty reaching the SkyNet group, use the following phone number and information:

(415) 692-9500 in Burlingame, California
Contact person—Charlene

City, Country	Company Name	Phone Number
Geneva, Switzerland	Schneider's	41227984468
Zurich, Switzerland	Schneider's	41181463699
Munich, Germany	SkyNet	498958045
Dusseldorf, Germany	SkyNet	49211370136
Frankfurt, Germany	West Air Courier	4969780087
Hamburg, Germany	Der Courier/SkyNet	4940291917
Berlin, Germany	Die Expressboten	4930850088
Paris, France	ExtraCom	33140115500
London, England	Sky International	44895445580
Sydney, Australia	SkyNet	6123164855
Taipei, Taiwan	Zip Express	88627603729
Vienna, Austria	ASAP/SkyNet	432227129652
Caracas, Venezuela	Sky Courier Intl	5827818210
Mexico City, Mexico	SkyNet de Mexico	5256892944
Peru, Chile	SkyNet	094701491
Sao Paulo, Brazil	Fex Express	55112410344
Milan, Italy	Intl Cargo Systems	392516951
Rome, Italy	Intl Cargo Systems	03965506008
Toronto, Canada	Elite Link	4168471072
Madrid, Spain	Sky Courier Intl	3417263007
Seoul, Korea	Air Couriers, Intl	8223252010
Stockholm, Sweden	Spedman/Courex	46859127290
Bombay, India	Sky Couriers	0226349747
Tokyo, Japan	Nissin Air Cargo	81476326506

Table 7-1 International SkyNet Branch Offices and Phone Numbers

Index

/stand directory 6-3

A

antistatic bag 7-1
antistatic mat 3-2, 3-4, 3-7, 4-1, 4-10
ASCII terminal 6-1, 6-4
ASIC
 dynamic RAM control (DCC) 1-2
 MP Bus-to-Memory Interface 1-2
 R4000-to-Memory Interface 1-2
 R4000-to-MP Bus Interface 1-2

B

backplane
 connectors 1-4
board
 block diagram 1-3
 CPU 1-1, 3-2, 3-4, 3-7
 ejector tabs 3-2, 3-4, 3-7
 Eurocard 1-2
 installation 5-1
 IO3 1-2
 IO3B 1-2
 IP 7-1
 IP17 1-2, 2-1, 2-3, 4-1, 4-5, 4-10, 5-3, 6-1, 6-3
 locations 5-3
 packing 7-1
 PP2 3-2
 slot assignments 5-3
 testing 6-3
bus
 MP 1-2
 MP arbiter 1-2

C

CD-ROM 6-3
chassis
 rack-mounted 3-4, 5-3
 single tower 3-5, 5-3
 twin tower 3-2, 5-3
chassis preparation 3-1
 rack-mounted 3-3
 single tower 3-5
 twin tower 3-2
command
 help 6-5
 hinv 2-3, 6-2
 menu 6-6
Command Monitor 6-2
connectors
 backplane 1-4
 IP 5-3
 power 1-4
control characters 6-5
control line buffers 1-2
CPU tests 6-6

D

DCC 1-2
diagnostics 6-1
 commands 6-4
 installation 6-4
 running 6-6
 stand-alone 6-3
 System Maintenance Menu 6-2, 6-4
dynamic 1-2

E

ejector tabs 3-2, 3-4, 3-7
electrostatic discharge, see ESD
ESD 2-2, 3-2, 3-4, 3-6, 4-1, 4-10
Eurocard 1-2
Eurocard board 1-2

F

fan assembly kit 2-1
floating point coprocessor 1-1

G

graphics subsystems
 GTX 1-2
 PowerVision 1-2
GTX 1-2

H

high density SIMMs 1-2
HU 2-1
HU-4DCRIMCP 1-1, 2-1
HU-4DCRIMCPB 2-3

I

I/O door 2-3, 3-2, 3-4, 3-5, 5-4
I/O panel 3-2
IDE diagnostics 2-3
installation
 IP17 5-3
interface
 MP Bus-to-memory 1-2
 R4000-to-memory 1-2
 R4000-to-MP Bus 1-2
 sync bus 1-2
IO3 1-2
IO3B 1-2
IP17 1-2, 2-1
 features 1-2
IRIS 1-1
IRIX 4D1-4.0.3 1-1, 6-1

J

jumpers 5-1
 block B009 5-1

L

Labeling 7-1
labels
 RMA 7-1
 system 2-3, 5-4
 tophat 2-3, 5-4
low density SIMMs 1-2

M

materials 3-1, 4-1
memory
 configuration 1-2, 4-1
 installation 4-1
 on-board 1-2
 subsystem 1-2
memory configuration
 IP17 4-3
memory subsystem 1-2
memory tests 6-7
MP bus 1-2
 arbiter 1-2

O

obsolete hardware 7-1
operating system
 IRIX 4D1-4.0.3 1-1, 2-1
 tape 6-4
 version 4.0.3 2-3

P

ports
 RS-232 1-2
 serial 6-1
power connector 1-4
power indicators 1-4
POWER Series systems 1-1
PowerVision 1-2

R

R4000-50 CPU 1-2
RISC 1-1

contents 2-1
upgrade steps
HU-4DCRIMCPB 2-3

S

secondary cache 1-2
serial port 6-1
shipping 7-2
SIMMs 1-2, 2-3, 4-1
 banks 4-3
 blocks 4-3
 combinations 4-4
 configuration 4-3
 high and low density combinations 4-8, 4-9
 high density 1-2, 4-4, 4-5, 4-6
 installation 4-4, 4-10
 low density 1-2, 4-4, 4-5, 4-7
 release tabs 4-1
 removing 4-1, 4-2
 slot 4-1
 sockets 1-4, 4-3
 storage 4-1
single in-line memory modules, see SIMMs
software
 version 4D1-4.0.3 1-1
stand-alone diagnostics 6-3
status indicators 1-4
Sync Bus 1-2
system labels 5-4
System Maintenance Menu 6-2, 6-4
system preparation 3-1
systems
 POWER Series 2-3
 R4000-50 1-1, 2-3
 rack-mounted 3-4

T

tools 3-1, 4-1
twin tower
 preparation 3-2

U

upgrade kits

